



TN-1

SERIES 3700 CAPACITIVE ACCELEROMETERS OPERATING PRINCIPLE

Series 3700 Capacitive Accelerometers Operating Principle

In the simplest sense, capacitive accelerometers operate on a technique where the capacitance of the internal sensing element changes in proportion to the applied acceleration.

In Series 3700 Capacitive Accelerometers, the sensing element mechanism consists of a "washer-shaped," seismic mass (m) suspended by a proprietary flexure with stiffness (k). This assembly is sandwiched between two circular plates with a plated electrode area (A), whose distance (d) is closely controlled with precision, chemically-etched spacers. The resulting air-gap between each electrode and the seismic mass forms a "mechanically variable capacitor". A cross-sectional drawing of this sensing element under a "0 g" condition is depicted in Figure 1. Figure 2 depicts a "+1 g" condition as may be experienced by the sensor as it rests in the Earth's Gravitational Field.

When the element is accelerated (a) as shown in Figure 2, an inertial force (F) is created on the mass (m) in accordance with Newton's Second Law of Motion:

$$F = ma \quad (\text{Eq. 1})$$

This force causes the mass to move a certain distance (X) closer to the lower electrode and the same distance (X) farther from the upper electrode. This distance depends on the flexure stiffness (k) and is represented by the simple Spring Equation:

$$X = F/k \quad (\text{Eq. 2})$$

The change in distance correspondingly changes the capacitance (C).

$$C_1 = (A\epsilon) / (d+X) \quad (\text{Eq. 3})$$

$$C_2 = (A\epsilon) / (d-X) \quad (\text{Eq. 4})$$

where,

A = Electrode Area

ϵ = Permittivity of Air

d = Distance between Mass and Electrode under 0 g condition

X = Displacement of Mass

Built-in microelectronics utilize a capacitive bridge circuit to convert the capacitance change into a useful voltage signal. A simplified schematic of the circuit is shown in Figure 3. The theoretical

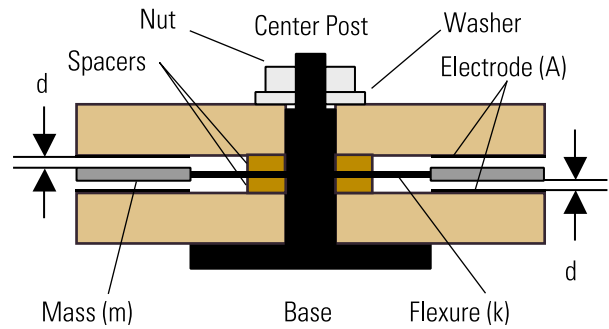

Figure 1: Sensing Element in "0 g" Condition

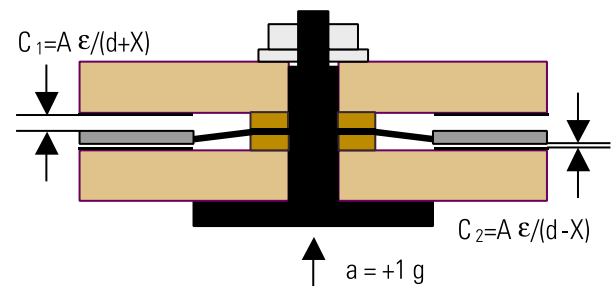

Figure 2: Sensing Element in "+1g" Condition

response from the +1 g acceleration shown in Figure 2 is depicted by the time traces shown in Figure 4 and an explanation follows.

Power to the circuit is in the form of a simple DC voltage. This voltage can be derived from laboratory power supplies, automotive / marine batteries or other portable power sources. Initially, the power is passed through a voltage regulator. This regulator ensures clean power to microelectronics and fixes the amplitude of the subsequent oscillator chip. By fixing the amplitude of the oscillator output as seen at Location 1, the sensitivity of the accelerometer becomes independent of the supply voltage. This is advantageous since precise calibration of the power supply becomes unnecessary.

Next, the oscillator output is directed into the capacitive-bridge, where the signal "splits" and travels into each arm of the bridge. Each arm acts as a capacitor divider. The resulting amplitude of the amplitude-modulated signal at Locations 2 and 3 is directly proportional to the changes in capacitance experienced by the sensing element.

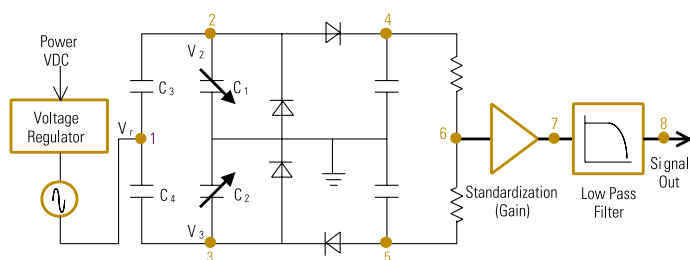

Figure 3: Circuit Schematic

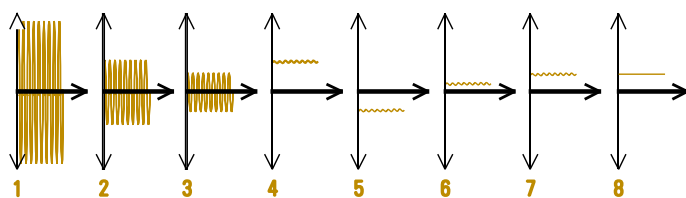

Figure 4: Response from Circuit due to applied +1g Static Acceleration (x-axis = time and y-axis = voltage)

$$V_2 = V_r * (1/C_3) / [(1/C_3) + (1/C_1)] \quad (\text{Eq. 5})$$

$$V_3 = V_r * (1/C_4) / [(1/C_4) + (1/C_2)] \quad (\text{Eq. 6})$$

The signals are then passed through a series of diodes and capacitors. These demodulated signals appear at Locations 4 and 5. The signals are summed together at Location 6. At this point, the electrical signal is proportional to the input acceleration.

It would be sufficient to complete the circuit at this point, however, a couple additional features are included to enhance the performance of the sensor. The first feature is the addition of a "standardization" amplifier. This is used to "trim" the range of the sensor to a convenient number such as 3 g, 20 g, 50 g or 200 g. For example, in Figure 3 this amplifier is used to gain the signal by a factor of 2. In other words, the voltage at Point 7 is twice as large as it is at Point 6. The second feature is a low-pass electrical filter. This filter is used

to reduce unwanted signals from high-frequency vibration and eliminate any residual effects of the oscillator frequency.

After the sensor has been installed and the cable connected for proper operation, there are a few measurement points to take note of:

- 1 After providing power to the sensor, it may be used immediately for taking measurements above 0.1 Hz. However, the sensor requires approximately 15 minutes to fully stabilize itself for tilt measurements or other applications requiring absolute, DC response.
- 2 To take advantage of the true DC response of the accelerometer, the readout device must be in a DC coupled state. Consult the appropriate manufacturer or product manual for details.
- 3 Since Series 3700 Capacitive Accelerometers can measure static acceleration, their DC offset voltage will be affected by their positional alignment relative to the Earth's gravity. In other words, and as shown in Figure 5, when the sensor is mounted perpendicular with the Earth's surface, the offset will equal that as listed on the calibration certificate for "zero-g offset voltage." If the sensor is mounted parallel with the Earth's surface, as shown in Figure 6, the sensor will be experiencing 1 g of acceleration and the offset voltage will increase by the sensitivity of the accelerometer.

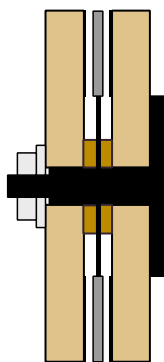

Figure 5: Sensing Element in "0g" Condition with Respect to Earth's Gravity

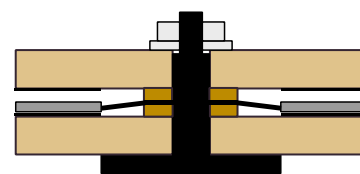

Figure 6: Sensing Element in "+1g" Condition with Respect to Earth's Gravity



3425 Walden Avenue, Depew, NY 14043-2495 USA

Toll-Free in the USA: 800 828 8840

Phone: 1 716 684 0001 | Email: info@pcb.com

PCB Piezotronics, Inc. is a designer and manufacturer of microphones, vibration, pressure, force, torque, load, and strain sensors, as well as the pioneer of ICP® technology used by design engineers and predictive maintenance professionals worldwide for test, measurement, monitoring, and control requirements in automotive, aerospace, industrial, R&D, military, educational, commercial, OEM applications, and more. With a worldwide customer support team, 24-hour SensorLineSM, and a global distribution network, PCB® is committed to Total Customer Satisfaction. Visit www.pcb.com for more information. PCB Piezotronics, Inc. is a wholly owned subsidiary of MTS Systems Corporation. Additional information on MTS can be found at www.mts.com.

© 2019 PCB Piezotronics, Inc. In the interest of constant product improvement, specifications are subject to change without notice. PCB®, ICP®, Swiveler®, Modally Tuned®, and IMI® with associated logo are registered trademarks of PCB Piezotronics, Inc. in the United States. ICP® is a registered trademark of PCB Piezotronics Europe GmbH in Germany and other countries. UHT-12™ is a trademark of PCB Piezotronics, Inc. SensorLineSM is a service mark of PCB Piezotronics, Inc. SWIFT® is a registered trademark of MTS Systems Corporation in the United States.

TN_1_0219



MTS Sensors, a division of MTS Systems Corporation (NASDAQ: MTSC), vastly expanded its range of products and solutions after MTS acquired PCB Piezotronics, Inc. in July, 2016. PCB Piezotronics, Inc. is a wholly owned subsidiary of MTS Systems Corp.; IMI Sensors and Larson Davis are divisions of PCB Piezotronics, Inc.; Accumetrics, Inc. and The Modal Shop, Inc. are subsidiaries of PCB Piezotronics, Inc.