

Reciprocating Machinery Protector

For Machinery Health Monitoring of Reciprocating Compressors

Highlights

- Outperforms impact transmitters
- Provides early warning of faults and mechanical looseness
- Outputs exclusive Reciprocating Fault Index (RFI)
- Provides continuous peak acceleration trending
- Optimizes performance with field programmable set points and alarm levels
- Eliminates false trips
- Hermetically sealed, 4-20 mA loop powered device
- Field programmable with USB interface (Model 070A82)



Model 649A01
Reciprocating Machinery Protector
(US Patent Number 7,171,313)

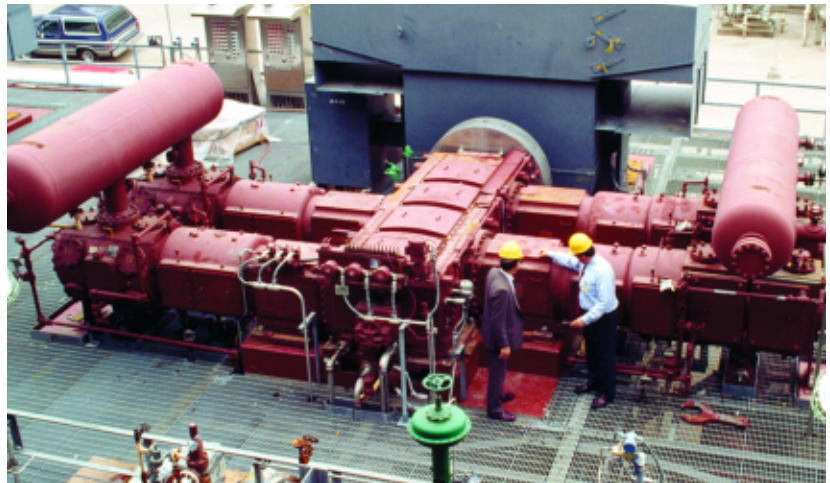

Photo Courtesy of Dresser Rand

Although overall vibration trending is an excellent tool for monitoring the health of rotating machinery, it is not generally effective for monitoring reciprocating machinery. Since impacts generally have little effect on overall vibration level, common faults are not detected at an early stage. As a result, abnormalities are not diagnosed until damage has occurred and it is too late to take simple corrective measures. There are several reciprocating machinery faults which do not significantly increase a machine's overall vibration level until damage has reached a severe level, including:

- Loose or broken bolts
- Loose or cracked rod nuts
- Cracked connecting or piston rod
- Excessive crosshead/slipper clearance
- Excessive clearance in connecting pins
- Liquid or debris in the cylinder
- Scoring in the cylinder
- Other broken parts

The patented IMI Sensors Reciprocating Machinery Protector (RMP) Model 649A01, is very sensitive to these faults in their early stages of development. For this reason, the RMP is particularly effective in monitoring reciprocating compressors. Model 649A01 is a loop-powered device which detects mechanical shock events occurring in or near the machine's cylinder assembly. The Reciprocating Machinery Protector continuously outputs the peak acceleration value, as long as there is no fault condition detected. When a threshold is exceeded, the RMP recognizes a potential fault condition and accurately outputs a computed Reciprocating Fault Index (RFI) proportional to the severity of the fault. With configurable speed parameters, adjustable sampling time, and ability to customize alarm levels, the RMP is a powerful tool for reciprocating machinery protection.



Model 649A01 Reciprocating Machinery Protector

Model 649A01 Specifications

Model Number	649A01	
Performance	English	SI
Feature Adjustments	Fully Programmable ^[1]	
Output	4-20 mA ^[2]	
Machinery Frequency Range	150 to 4800 cpm	2.5 to 80 Hz
Sampling Time	0.2 to 6.4 sec	
Lower Shock Threshold Level	2 to 50 g	
Upper Shock Threshold Level	2 to 50 g	
Weighting Factor (Lower & Upper)	0.1 to 20 mA	
Maximum Peak Trading Current	4-20 mA	
Cross Axis Response	< 3%	
Performance	English	SI
Excitation Voltage	15-30 VDC	
Maximum Load Resistance	50 ohm	
Environmental		
Operating Temperature Range	-40 to +212 °F	-40 to +100 °C
Storage Temperature Range	-40 to +257 °F	-40 to +125 °C
Overload Limit (Shock)	5000 g pk	49,050 m/s ² pk
Physical		
Size (Hex x Height)	1.25 x 2.60 in	1.25 in x 66 mm
Weight	7 oz	198 gm
Mounting Thread	1/4-28 Female	
Mounting Torque	3 to 5 ft-lb	4 to 7 N-m
Sensing Element	Ceramic Flexural	
Housing Material	Stainless Steel	
Sealing	Welded Hermetic	
Electrical Connector	2-pin MIL-C-5015	
Electrical Connections (Pin A)	4-20 mA Pos (+)	
Electrical Connections (Pin B)	4-20 mA Neg (-)	
Optional Versions		
Metric Installation	M	
Supplied Accessories		
Model 081A40 mounting stud for top exit sensors (Model M081A61 for metric installation)		
[1] Field programmable features available using optional USB programmer Model 070A82		
[2] Output proportional to peak acceleration and number of impacts over two thresholds with specific weight in sample time		

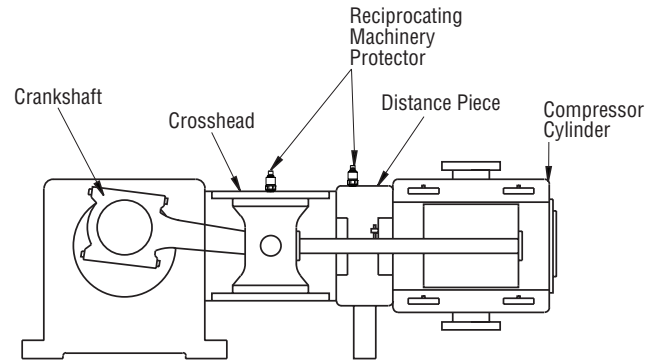

Suggested mounting locations on crosshead or distance piece are ideal for optimum performance

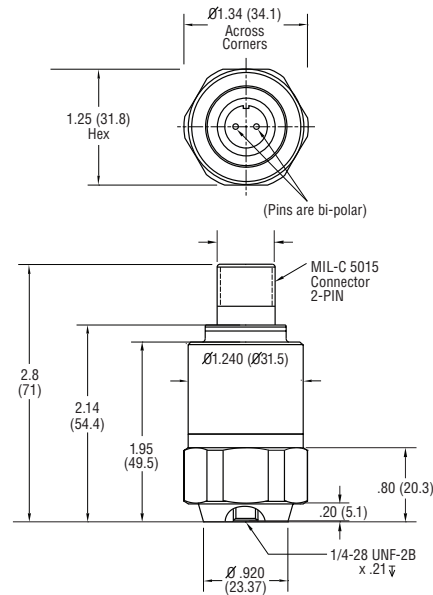

Model 649A01

Reciprocating Machinery Protector
Dimensions shown are in inches (millimeters)



3425 Walden Avenue, Depew, NY 14043-2495 USA

IMI Sensors Division toll free 800-959-4464

24-hour SensorLineSM 716-684-0003

Fax 716-684-3823 E-mail imi@pcb.com

Web site www.imi-sensors.com

ISO 9001:2000 CERTIFIED

A2LA ACCREDITED to ISO 17025

© 2007 PCB Group, Inc. In the interest of constant product improvement, specifications are subject to change without notice.
PCB, IMI with associated logo, ICP, Swiveler, and Spindler are registered trademarks of PCB Group, Inc.
SensorLine is a service mark of PCB Group, Inc. All other trademarks are properties of their respective owners.

IMI-649A01-0707

Printed in U.S.A.

The IMI Sensors Division of PCB® Piezotronics, Inc. specializes in the development, application, and support of industrial vibration sensors, transmitters, switches, meters, and accessories for machinery condition monitoring and predictive maintenance requirements. This product focus, coupled with the strengths and resources of PCB®, permits the IMI Sensors Division to offer exceptional customer service, 24-hour technical assistance, and a **Total Customer Satisfaction** guarantee.

Visit www.imi-sensors.com to locate your nearest sales office