

SERIES 356A4X

MINIATURE TRIAxIAL ICP® ACCELEROMETERS WITH TEDS

- Small size and lightweight
- TEDS IEEE 1451.4 enabled
- Wide frequency bandwidth
- High resonant frequency
- Hermetically sealed titanium housing
- Ground isolated (J) option



Models 356A43, 356A44 and 356A45 are miniature and lightweight triaxial ICP® accelerometers that are TEDS IEEE 1451.4 enabled. The accelerometers are hermetically sealed and packaged in a 0.4 inch (10.16 mm) titanium cube that weighs 0.15 ounces (4.2 grams). The TEDS feature self identifies these accelerometers and describes the type, operation, and their attributes making them extremely easy for the operator to track. J version models are ground isolated to reduce electrical noise and ground loops.

TYPICAL APPLICATIONS

- Modal and structural analysis
- NVH studies on automotive parts
- Space restricted installations
- Drop testing and package testing
- Small component qualification testing
- General purpose vibration testing

CE

SPECIFICATIONS	356A43 J356A43	356A44 J356A44	356A45 J356A45
Performance			
Sensitivity Tolerance ($\pm 10\%$)	10 mV/g [1.02 mV/(m/s ²)]	50 mV/g [5.1 mV/(m/s ²)]	100 mV/g [10.2 mV/(m/s ²)]
Measurement Range	± 500 g pk [± 4905 m/s ² pk]	± 100 g pk [± 981 m/s ² pk]	± 50 g pk [± 490 m/s ² pk]
Frequency Range ($\pm 5\%$)	0.7 – 7,000 Hz		
Frequency Range ($\pm 10\%$)	0.4 – 10,000 Hz		
Resonant Frequency	≥ 30 kHz		
Non-linearity	0.0008 g rms [0.008 m/s ² rms]	0.0006 g rms [0.006 m/s ² rms]	0.0005 g rms [0.005 m/s ² rms]
Transverse Sensitivity	$\leq 1\%$		
Transverse Sensitivity	$\leq 6\%$		
TEDS Compliant (IEEE 1451.4)	Yes		
Environmental			
Overload Limit (Shock)	± 5000 g pk [$\pm 49,050$ m/s ² pk]		
Temperature Range (Operating)	-65 to +250 °F	-65 to +200 °F	-65 to +185 °F
	-54 to +121 °C	-54 to +93 °C	-54 to +85 °C
Electrical			
Excitation Voltage	20-30 VDC		
Constant Current Excitation	2-20 mA		
Electrical Isolation	1 x 10 ⁹ ohm (J option only)		
Physical			
Housing Material	Titanium		
Sealing	Hermetic		
Weight	0.15 oz [4.2 g]		
Electrical Connector	1/4 – 28 4-pin (side)		
	356A43, 356A44, 356A45		J356A43, J356A44, J356A45
Size (height x width x length)	0.4 x 0.4 x 0.75 in. (10.2 x 10.2 x 19.1 mm)		0.47 x 0.43 x 0.78 in. (11.8 x 11.0 x 19.8 mm)

4-CONDUCTOR CABLES:

Cable Series	010	034	019	036	078
Cable Style	General Purpose	General Purpose Low Noise	Flexible Lightweight	Flexible	Rugged Flexible
Jacket Material	FEP	FEP	Silicone	Silicone	Polyurethane
Cable Jacket Diameter	0.1 in	0.077 in	0.070 in	0.104 in	0.119 in
	2.54 mm	1.96 mm	1.77 mm	2.64 mm	3.02 mm
Temperature Range	-130 to +392 °F	-130 to +392 °F	-76 to +500 °F	-76 to +392 °F	-58 to +185 °F
	-90 to +200 °C	-90 to +200 °C	-60 to +260 °C	-60 to +200 °C	-50 to +85 °C
Pull Strength	34 lb	19 lb	10 lb	30 lb	25 lb
10-foot cable assembly model number**	010G10	034G10	019AY010JW	036G10	078G10

**The model numbers provided are for BNC plug terminated 10-foot cable assemblies compatible with the 356A4X series.

Model 356A4X

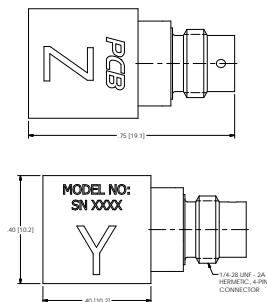
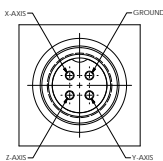

Model J356A4X

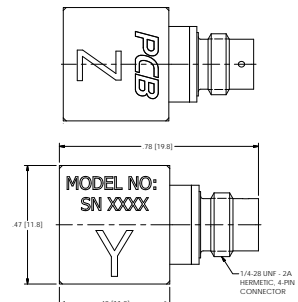
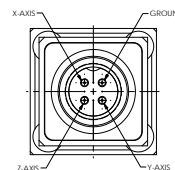

3425 Walden Avenue, Depew, NY 14043-2495 USA

Toll-Free in the USA: 800 828 8840

Phone: 1 716 684 0001 | Email: info@pcb.com

PCB Piezotronics, Inc. is a designer and manufacturer of microphones, vibration, pressure, force, torque, load, and strain sensors, as well as the pioneer of ICP® technology used by design engineers and predictive maintenance professionals worldwide for test, measurement, monitoring, and control requirements in automotive, aerospace, industrial, R&D, military, educational, commercial, OEM applications, and more. With a worldwide customer support team, 24-hour SensorLineSM, and a global distribution network, PCB® is committed to Total Customer Satisfaction. Visit www.pcb.com for more information. PCB Piezotronics, Inc. is a wholly owned subsidiary of MTS Systems Corporation. Additional information on MTS can be found at www.mts.com.

© 2019 PCB Piezotronics, Inc. In the interest of constant product improvement, specifications are subject to change without notice. PCB®, ICP®, Swiveler®, Modally Tuned®, and IMI® with associated logo are registered trademarks of PCB Piezotronics, Inc. in the United States. ICP® is a registered trademark of PCB Piezotronics Europe GmbH in Germany and other countries. UHT-12™ is a trademark of PCB Piezotronics, Inc. SensorLineSM is a service mark of PCB Piezotronics, Inc. SWIFT® is a registered trademark of MTS Systems Corporation in the United States.

TM-VIB-356A43-44-45-0419



MTS Sensors, a division of MTS Systems Corporation (NASDAQ: MTSC), vastly expanded its range of products and solutions after MTS acquired PCB Piezotronics, Inc. in July, 2016. PCB Piezotronics, Inc. is a wholly owned subsidiary of MTS Systems Corp.; IMI Sensors and Larson Davis are divisions of PCB Piezotronics, Inc.; Accometrics, Inc. and The Modal Shop, Inc. are subsidiaries of PCB Piezotronics, Inc.