



TN-20

# Data Validation: A Prerequisite to Performing Data Uncertainty Analysis

Written By

Patrick L. Walter, Ph. D.

# DATA VALIDATION: A PREREQUISITE TO PERFORMING DATA UNCERTAINTY ANALYSIS

Patrick L. Walter, Ph. D

Measurement Specialist, PCB Piezotronics, Inc.  
Depew, NY 14043

Engineering Faculty, Texas Christian University  
Fort Worth, TX 76129

## Abstract

There are increasing demands, particularly from government agencies, to perform uncertainty analysis in order to assign accuracy bounds to telemetered data from environmental measuring transducers (pressure, acceleration, force, strain, temperature, etc.). Several requirements must be fulfilled before measurement uncertainty analysis is justified. These requirements include good measurement system design practices such as adequate low- and high-frequency response and data-sampling rates, appropriate anti-aliasing filter selection<sup>1</sup>, proper grounding and shielding, and many more.

In addition, there are applications (e.g., flight test) in which the environment of the transducer varies with time and/or location. In these applications, it is a requisite that data-validation be performed to establish that an individual transducer responds only to the environmental stimulus that it is intended to measure. Without this validation component designed into the telemetry system, assigned accuracy bounds can be totally meaningless. This paper presents examples and describes techniques for data validation of signals from environmental measuring transducers.

## Keywords

Data-validation, transducer, data accuracy, uncertainty analysis

## Introduction

Procedures for performing uncertainty analysis<sup>2</sup> to assign accuracy bounds to measured data are presented in numerous textbooks. These bounds can easily be established if the measurement system operates in a fixed environment. However, many environments, particularly those associated with flight, vary as a function of both space and time. These variations, which often are not

quantified or even identified, can invalidate any preflight uncertainty analysis performed.

For example, consider the February 1, 2003, structural breakup of the space shuttle Columbia. When scientists attempted to reconstruct re-entry events using data acquired concurrent with the failure, the most critical data were generated while the instruments were operating well outside of their specified environmental capabilities. Of necessity, the focus of data analysis activities shifted from accuracy to whether the data even possessed any relevant physical significance.

The intent of this paper is to outline procedures for data validation in flight environments. Data validation is essential before data uncertainty analysis can be performed. Most authors of uncertainty analysis textbooks do not emphasize, and may not even recognize, this fact.

## Body

The goal of physical (force, pressure, acceleration, strain, temperature, ...) measurements during flight-testing is either to verify predicted flight environments or identify if established flight limits have been exceeded. Data assessment depends on structural, thermal, or other relevant analysis to establish acceptable data bounds. A measurement system must then be designed and calibrated specifically for the appropriate physical measurements.

Since all of the attributes of a flight environment may not be known (or even suspected), data-validation<sup>3</sup> channels must also be allocated to the test. If these validation channels indicate that the measured data have not been compromised, data accuracy numbers can be assigned. Figure 1 illustrates this entire sequence of events. The goal of this paper is to provide clarity with respect to the manner in which this data *validation* process is implemented.

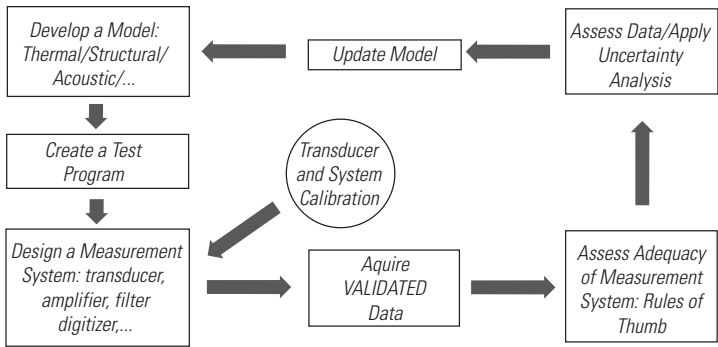

**Figure 1: Analysis, Test, Measure and Data-Validation Synergies**

The front end of any physical measurement system is the transducer. Transducer responses can be categorized as: (1) non-self generating (e.g., a bridge with variable-resistance, -capacitance, or -inductance elements that require external power) or (2) self-generating (piezoelectric, thermoelectric, photoelectric, magnetolectric, etc.).

Having established these two types of responses, it must be recognized that both types are susceptible to two classes of environmental inputs: desired and undesired. (For example, the *desired* environmental input to an accelerometer is clearly acceleration.) Thus, one can conclude that for every measurement system there exists four (4) response-input combinations (Figure 2).

Response Type	Environmental Input
Non-self generating	Desired
Self-generating	Undesired

**Figure 2: Four (4) Transducer-Response Combinations**

Using the table of Figure 2, a definition for the signal output from a measurement system can be established. *Signal* is defined as the correct response type to the desired environmental input. For example, consider the case of a piezoresistive accelerometer. For this example, the non-self generating response (resistance change) to the *desired* environment (acceleration) is the *signal*. It is the object of the measurement.

The non-self generating response to the *undesired* environments, as well as the self-generating response to both the *desired* and *undesired* environments, is noise. Examples of these noise effects could include: resistance

changes due to temperature as opposed to acceleration; and self-generated outputs due to thermoelectric effects in the transducer wiring. Figure 3 diagrammatically illustrates the paths associated with these four combinations, path 4 being signal, and paths 1, 2, and 3 being noise. This example can be generalized to any bridge-type transducer.

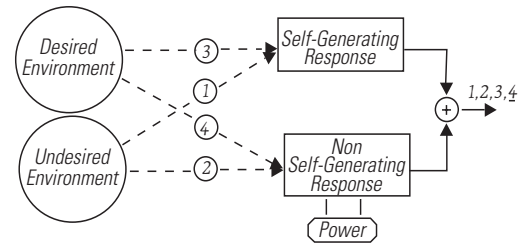

**Figure 3: Non-self Generating Transducer Model**

(Numerous technical agencies such as the International Society for Measurement and Control (ISA) have published specifications and test guides for various types of transducers. One such publication is the “Guide for Specifications and Tests for Piezoelectric Acceleration Transducers for Aero-Space Testing.” (ISA-RP37.2-1982<sup>4</sup>). Included within this document are specifications to minimize the response of accelerometers to the *undesired* environmental inputs of steady-state and transient temperature, base strain, acoustic pressure, magnetic fields, humidity, radio interference, and nuclear radiation.)

The goal in any measurement system is to assure that the path defined as signal is the only one that is present to a significant extent. Some question may arise as to how to implement this verification. An acceptable method for the preceding example would be to field three accelerometers in close proximity.

The first accelerometer could be mounted without electrical power applied to document paths 1 and 3. Note that without power, paths 2 and 4 are not possible. The second accelerometer could have power applied but be mounted on a piece of foam (or suspended in air) to isolate it from the acceleration environment, resulting in documentation of paths 1 and 2. Note that without the desired environment (acceleration) present, paths 3 and 4 are not possible. The third accelerometer could be mounted with power properly applied to measure the acceleration environment. If the first two accelerometers produced no output, *paths 1, 2, and 3 would be documented not to be present and the output from the third*

accelerometer would be path 4, which is the noise-free signal. Data worthy of subsequent uncertainty analysis would have been acquired!

For force and pressure transducers, the same type strategy applies. Simply install three force or pressure transducers in close proximity. Apply power to one, don't apply power to the second, and apply power but isolate the third from its intended force or pressure environment. For example, a pressure transducer could be mounted in a "blind hole" to assure its diaphragm is not exposed to pressure. It would still be exposed to vibration, strain, electromagnetic fields, and other undesired environments to which it could potentially respond.

The following example shows the efficacy of these noise documentation techniques. Figures 4a and 4b show launch acceleration acquired from resistive bridge accelerometers within a projectile in a gun environment<sup>5</sup>.

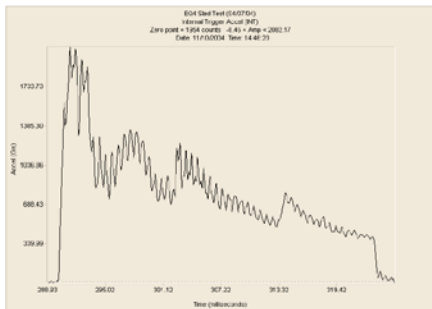

**Figure 4a: Legacy System**

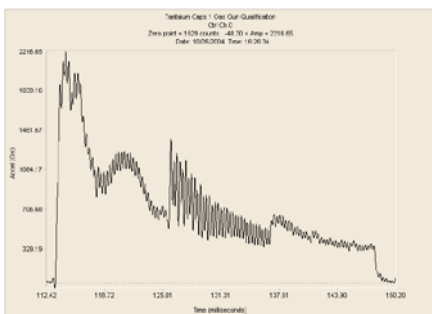

**Figure 4b: Proposed New System**

**Figure 4: Gun Launch Acceleration Time Measurement**

Figure 4a is data acquired from a legacy measurement system, which had been verified to be trustworthy through successful testing over many years. Figure 4b represents concurrent data from the initial test performed using a new,

higher-frequency measurement system. The initial results look encouraging. However, Figure 5 shows the results from recording a separate data channel with no power applied to the associated accelerometer. Any signal present in Figure 5 represents paths 1-3, which are noise.

When scaled, it can be shown that the peak noise signal in Figure 5 is more than 20% of the signal in Figure 4b. Since no power is on the accelerometer bridge, this signal is entirely attributable to some error source. Investigation showed its cause to be shock sensitivity of capacitors within the new measurement system. No pretest uncertainty analysis would have encompassed this error. Worse yet, if data validation had not been performed, the similarities between Figure 4a and 4b might have encouraged the adoption of the proposed new system without design corrections.

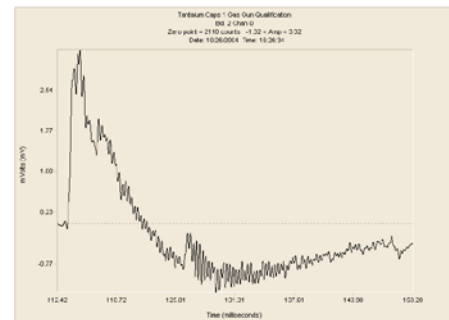

**Figure 5: Paths 1-3 Documentation for Proposed New System (4(b))**

While the foregoing, projectile-related example was provided for a non-self generating transducer, the following example is for a self-generating transducer. We will use the example of a piezoelectric accelerometer measuring acceleration. For piezoelectric transducers, "placebo" (IEST-RP-DTE011.1) transducers enable data validation to be accomplished. The referenced IEST standard defines a placebo transducer as 'identical to a "live" unit in every parameter except for mechanical sensitivities.' The placebo transducer should respond only to extraneous "environmental factors." Ideally, its output would be zero. Any signal output from it would indicate that the signals from the "live" transducers could be corrupted.

The manufacture of placebo transducers will now be clarified. Figure 6 shows a boule of quartz from which piezoelectric elements are cut in order to be integrated into

transducers for force, pressure, and acceleration. The boule possesses different piezoelectric properties for cuts in different directions, as illustrated by Equation set (1) below<sup>6</sup>. While the details of the system of equations aren't important for this discussion, note that the third equation in the set shows a direction (i.e., the z-axis) that produces no piezoelectric output. Cuts along this axis provide the quartz for the placebo transducers.

$$\begin{aligned}
 P_{XX} &= d_{11}\sigma_{XX} - d_{11}\sigma_{YY} + 0\sigma_{ZZ} + d_{14}\tau_{YZ} + 0\tau_{ZX} + 0\tau_{XY} \\
 P_{YY} &= 0\sigma_{XX} + 0\sigma_{YY} + 0\sigma_{ZZ} + 0\tau_{YZ} - d_{14}\tau_{ZX} - 2d_{11}\tau_{XY} \\
 P_{ZZ} &= 0\sigma_{XX} + 0\sigma_{YY} + 0\sigma_{ZZ} + 0\tau_{YZ} + 0\tau_{ZX} + 0\tau_{XY}
 \end{aligned} \quad (1)$$

where a "P" is a piezoelectric directional constant, a "d" is a piezoelectric coefficient, and a "σ" is a stress component.

As opposed to piezoelectric transducers for pressure and force, which almost exclusively use quartz, many accelerometers use ceramic-based materials for their sensing elements. These ceramics result from complex manufacturing processes. The commonality of the ceramic processing is this: In order to behave in a piezoelectric manner the ceramics must have a high poling voltage placed across their electrodes at a high temperature during the final stages of their manufacture (as illustrated in Figure 7). If this poling is intentionally skipped, an inert sensing element is produced, and it can be used in a placebo transducer. Neither the z-cut quartz nor the unpoled ceramic placebo transducers can produce a piezoelectric output. However, they do respond the same as a "live" transducer to the undesired environmental factors described previously.

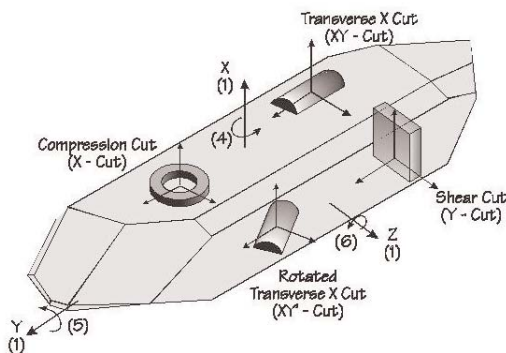

Figure 6: Quartz Boule



Figure 7: Poling Ceramics

Figures 8a and 8b illustrate the value of integrating placebo transducers into a test, which involves telemetered data<sup>7,8</sup>. The uppermost three of the four records in each figure are from live accelerometers and the bottom record is from a placebo accelerometer. Each set of four accelerometers was assigned to a specific telemetry transmitter, the frequencies of which are shown.

Data recorded during a weapons test were subsequently noted to be anomalous. After the test, the set of accelerometers on the 239.4 MHz transmitter was removed from the system, mounted to a metal plate, and impacted with results shown in Figure 8. The live accelerometers recorded data, as did the placebo! Not only that, but signals were emitted from all the accelerometers (live as well as placebo) on the 248.6 MHz channel, even though those accelerometers were not impacted. A ground loop was found to be the culprit, and bad data were not accepted as good. Design corrections to the measurement system were subsequently performed and erroneous data were not accepted thanks to the validation channels incorporated into the test.

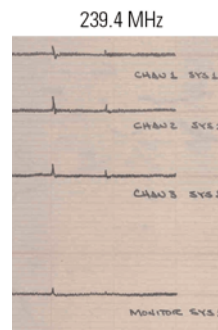

Figure 8a: Transmitter 1

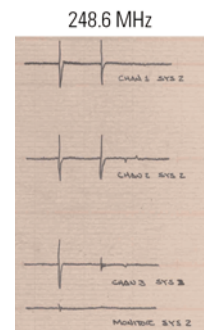
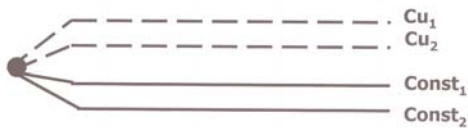

Figure 8b: Transmitter 2



While the above example has again focused on acceleration data, placebo transducers are equally useful in dynamic testing irrespective of whether force, pressure, acceleration, or other measurements are required. For example, strain measurements depend on resistive elements in a bridge circuit, and validation techniques for non-self generating transducers apply. Similarly, thermal measurements using resistance temperature detectors (RTDs) depend on a resistance change with temperature and also follow the non-self generating model.

Thermocouples follow a self-generating transducer model. Figure 9 shows one method to validate their signal. Two thermocouple pairs (in this instance copper-constantan) are built with a common junction. Thus, both thermocouples should provide the same temperature indication. In addition, the output from the constantan-constantan and copper-copper pairs can also be determined, which should be zero. The combination of appropriate readings on all of these data channels would indicate a valid temperature measurement.



**Figure 9: Thermocouple Circuit Validation**

### Conclusion

The preceding material has served to illustrate the data-validation process. It has shown several methods by which to perform data validation and has also shown the value of data-validation in documenting erroneous signals. When measurement systems are required to operate in situations where their environmental boundaries are not fixed,

validation channels should always be provided. The final configuration and utility of these channels is limited only by the resourcefulness of the instrumentation engineer. Without the presence of these channels, data accuracy bounds based on uncertainty analysis remain questionable.

### Acknowledgements

Prof. Emeritus Peter K. Stein initiated my journey down the road of data validation as a structured process, and Jim Lally, CEO PCB Piezotronics, saw the utility of and then manufactured the first z-cut quartz placebo transducers.

### References

1. Walter, Patrick L., "Optimizing Flight Shock And Vibration Measurement by RF Links," International Telemetry Conference, 1998.
2. Dieck, Ronald H., Measurement uncertainty: methods and applications, Research Triangle Park, NC, ISA, 2002.
3. Stein, Peter K., The Unified Approach to the Engineering of Measurement Systems, Stein Engineering Services, ISBN#1-881472-00-0, Phoenix, AZ, 1992.
4. Standards and Recommended Practices for Instrumentation and Control, 10th Edition, Vol. 1, Instrument Society of America, Research Triangle Park, NC, 1989.
5. Partridge, Michael E., Sandia National Laboratories, personal communication to author, November 16, 2004.
6. Neubert, Hermann K. P., Instrument Transducers, 2<sup>nd</sup>, Clarendon Press, Oxford, p. 257, 1975.
7. Walter, Patrick L., "Placebo Transducers: A Tool for Data Validation," Tech Note 16, PCB Piezotronics, Depew, NY, 2005.
8. Walter, Patrick L., "Air Blast and the Science of Dynamic Pressure Measurements," Sound and Vibration, pp. 10-16, December 2004.

### Note

This paper is a reprint of an original paper prepared by the author for the 2005 International Telemetry Conference. While its focus is flight telemetry, the techniques described are equally applicable to signals transmitted via cables.



**3425 Walden Avenue, Depew, NY 14043 USA**

pcb.com | info@pcb.com | 800 828 8840 | +1 716 684 0001

© 2022 PCB Piezotronics - all rights reserved. PCB Piezotronics is a wholly-owned subsidiary of Amphenol Corporation. Endevo is an assumed name of PCB Piezotronics of North Carolina, Inc., which is a wholly-owned subsidiary of PCB Piezotronics, Inc. Accumetrics, Inc. and The Modal Shop, Inc. are wholly-owned subsidiaries of PCB Piezotronics, Inc. IMI Sensors and Larson Davis are Divisions of PCB Piezotronics, Inc. Except for any third party marks for which attribution is provided herein, the company names and product names used in this document may be the registered trademarks or unregistered trademarks of PCB Piezotronics, Inc., PCB Piezotronics of North Carolina, Inc. (d/b/a Endevo), The Modal Shop, Inc. or Accumetrics, Inc. Detailed trademark ownership information is available at [www.pcb.com/trademarkownership](http://www.pcb.com/trademarkownership).

TN\_20\_0122