



Model 117B66

Installation and Operating Manual

**For assistance with the operation of this product,
contact the PCB Piezotronics, Inc.**

Toll-free: 716-684-0001

24-hour SensorLine: 716-684-0001

Fax: 716-684-0987

E-mail: info@pcb.com

Web: www.pcb.com



Repair and Maintenance

PCB guarantees Total Customer Satisfaction through its “Lifetime Warranty Plus” on all Platinum Stock Products sold by PCB and through its limited warranties on all other PCB Stock, Standard and Special products. Due to the sophisticated nature of our sensors and associated instrumentation, **field servicing and repair is not recommended and, if attempted, will void the factory warranty.**

Beyond routine calibration and battery replacements where applicable, our products require no user maintenance. Clean electrical connectors, housings, and mounting surfaces with solutions and techniques that will not harm the material of construction. Observe caution when using liquids near devices that are not hermetically sealed. Such devices should only be wiped with a dampened cloth—never saturated or submerged.

In the event that equipment becomes damaged or ceases to operate, our Application Engineers are here to support your troubleshooting efforts 24 hours a day, 7 days a week. Call or email with model and serial number as well as a brief description of the problem.

Calibration

Routine calibration of sensors and associated instrumentation is necessary to maintain measurement accuracy. We recommend calibrating on an annual basis, after exposure to any extreme environmental influence, or prior to any critical test.

PCB Piezotronics is an ISO-9001 certified company whose calibration services are accredited by A2LA to ISO/IEC 17025, with full traceability to SI through N.I.S.T. In addition to our standard calibration services, we also offer specialized tests, including: sensitivity at elevated or cryogenic temperatures, phase response, extended high or low frequency response, extended range, leak testing, hydrostatic pressure testing, and others. For more information, contact your local PCB Piezotronics distributor, sales representative, or factory customer service representative.

Returning Equipment

If factory repair is required, our representatives will provide you with a Return Material Authorization (RMA) number, which we use to reference any information you have already provided and expedite the repair process. This number should be clearly marked on the outside of all returned package(s) and on any packing list(s) accompanying the shipment.

Contact Information

PCB Piezotronics, Inc.
3425 Walden Ave.
Depew, NY14043 USA
Toll-free: (800) 828-8840
24-hour SensorLine: (716) 684-0001
General inquiries: info@pcb.com
Repair inquiries: rma@pcb.com

For a complete list of distributors, global offices and sales representatives, visit our website, www.pcb.com.

Safety Considerations

This product is intended for use by qualified personnel who recognize shock hazards and are familiar with the precautions required to avoid injury. While our equipment is designed with user safety in mind, the protection provided by the equipment may be impaired if equipment is used in a manner not specified by this manual.

Discontinue use and contact our 24-Hour Sensorline if:

- Assistance is needed to safely operate equipment
- Damage is visible or suspected
- Equipment fails or malfunctions

For complete equipment ratings, refer to the enclosed specification sheet for your product.

Definition of Terms and Symbols

The following symbols may be used in this manual:



DANGER

Indicates an immediate hazardous situation, which, if not avoided, may result in death or serious injury.

**CAUTION**

Refers to hazards that could damage the instrument.

**NOTE**

Indicates tips, recommendations and important information. The notes simplify processes and contain additional information on particular operating steps.

The following symbols may be found on the equipment described in this manual:



This symbol on the unit indicates that high voltage may be present. Use standard safety precautions to avoid personal contact with this voltage.



This symbol on the unit indicates that the user should refer to the operating instructions located in the manual.



This symbol indicates safety, earth ground.



PCB工业监视和测量设备 - 中国RoHS2公布表

PCB Industrial Monitoring and Measuring Equipment - China RoHS 2 Disclosure Table

部件名称	有害物质					
	铅 (Pb)	汞 (Hg)	镉 (Cd)	六价铬 (Cr(VI))	多溴联苯 (PBB)	多溴二苯醚 (PBDE)
住房	0	0	0	0	0	0
PCB板	X	0	0	0	0	0
电气连接器	0	0	0	0	0	0
压电晶体	X	0	0	0	0	0
环氧	0	0	0	0	0	0
铁氟龙	0	0	0	0	0	0
电子	0	0	0	0	0	0
厚膜基板	0	0	X	0	0	0
电线	0	0	0	0	0	0
电缆	X	0	0	0	0	0
塑料	0	0	0	0	0	0
焊接	X	0	0	0	0	0
铜合金/黄铜	X	0	0	0	0	0
本表格依据 SJ/T 11364 的规定编制。						
0：表示该有害物质在该部件所有均质材料中的含量均在 GB/T 26572 规定的限量要求以下。						
X：表示该有害物质至少在该部件的某一均质材料中的含量超出 GB/T 26572 规定的限量要求。						
铅是欧洲RoHS指令2011/65/ EU附件三和附件四目前由于允许的豁免。						

CHINA RoHS COMPLIANCE

Component Name	Hazardous Substances					
	Lead (Pb)	Mercury (Hg)	Cadmium (Cd)	Chromium VI Compounds (Cr(VI))	Polybrominated Biphenyls (PBB)	Polybrominated Diphenyl Ethers (PBDE)
Housing	O	O	O	O	O	O
PCB Board	X	O	O	O	O	O
Electrical Connectors	O	O	O	O	O	O
Piezoelectric Crystals	X	O	O	O	O	O
Epoxy	O	O	O	O	O	O
Teflon	O	O	O	O	O	O
Electronics	O	O	O	O	O	O
Thick Film Substrate	O	O	X	O	O	O
Wires	O	O	O	O	O	O
Cables	X	O	O	O	O	O
Plastic	O	O	O	O	O	O
Solder	X	O	O	O	O	O
Copper Alloy/Brass	X	O	O	O	O	O

This table is prepared in accordance with the provisions of SJ/T 11364.

O: Indicates that said hazardous substance contained in all of the homogeneous materials for this part is below the limit requirement of GB/T 26572.

X: Indicates that said hazardous substance contained in at least one of the homogeneous materials for this part is above the limit requirement of GB/T 26572.

Lead is present due to allowed exemption in Annex III or Annex IV of the European RoHS Directive 2011/65/EU.

**OPERATION MANUAL FOR
CONFORMAL BALLISTICS PRESSURE SENSOR
Series 117B**

1.0 INTRODUCTION

The Model 117B Conformal Sensor measures pressure inside metallic cartridges and paper or plastic shotshell, during firing of the round, without drilled holes in the round.

The sensor is mounted flush with the chamber walls, matching the curvature exactly. The expanded cartridge or shotshell transmits forces through the thin wall to the sensor.

The Model 117B is a conventional charge output type sensor using synthetic quartz as the piezoelectric sensing material.

An alignment guide now standard on all 117B Models, simplifies installation by automatically controlling rotational alignment of the sensor, leaving only the depth adjustment consideration.

2.0 DESCRIPTION

Refer to enclosed installation drawing for outline dimensions and physical description.

The basic sensor is a probe design with captivated hollow clamp nut. The clamp nut rotates independently of the probe body and serves to lift the sensor out of the mounting port as it is unscrewed.

The alignment device consists of a pin and slotted clamp assembly which fits tightly over the collar of the sensor.

The hardened steel pin is accurately aligned with the axis of the diaphragm curvature and when assembled into a precisely drilled mating hole in the barrel or calibration chamber, achieves near perfect rotational alignment of sensor diaphragm.

The slotted clamp arrangement allows for tolerance in the location of the guide pin hole in an axial direction on the test barrel or calibration adaptor.

The precise depth adjustment is obtained by the use of the correct thickness spacer selected from a set of 9 spacers of various thicknesses supplied with each sensor.

Once the proper thickness spacer is found, removal and re-installation now becomes a routine matter.

3.0 INSTALLATION

3.1 PORT PREPARATION

Prepare mounting port in accordance with installation drawing 117-20 (XX)-90 supplied as part of this manual.

NOTE: The installation port for the 117B is identical to that for the 117A.

Drill guide pin hole as shown in installation drawing, paying particular attention to locating C/L of hole exactly on C/L of barrel.

Do not use a drill that is worn, as this may cause the hole to be slightly undersized and the guide pin may bind as it is drawn into the hole.

It is extremely important that the guide pin hole be drilled parallel to the sensor mounting port to permit the guide pin to move freely into the hole.

NOTE: Each model variation of the 117B is designed to fit in a specific location (measured from the bolt face) on a specific ammunition caliber. Changing location and/or caliber will cause a mismatch of diaphragm curvature with cartridge case diameter since most cartridge cases are tapered.

3.2 INSTALLING THE SENSOR

After mounting holes have been prepared, proceed with installation as follows:

1. On most models of 117B, it is not important which side of the sensor is mounted toward the muzzle.

However, on certain types of ammunition (such as 20 mm cannon) which have a severe taper, the diaphragm has a matching taper in

**OPERATION MANUAL FOR
CONFORMAL BALLISTICS PRESSURE SENSOR
Series 117B**

the curvature. In these latter cases, the sensor forward side is identified with the legend "FWD" etched on the guide collar to which the slotted clamp is attached. The clamp must be removed to find this legend. If it does not appear, the sensor may be mounted with either side toward the muzzle.

2. Loosen slotted clamp, but do not remove clamp.
3. Select the middle thickness (.014) spacer from the set of nine (065A19) supplied and place it around sensor barrel.
4. Begin threading the sensor clamp nut into the threaded mounting port, sliding slotted clamp fore and aft as needed to allow guide pin to fully enter hole.

Continue to turn clamp nut into hole by hand or using 5/16 open end wrench.

Do not tighten when sensor bottoms.

5. Now tighten the screw closing slotted clamp.
6. Using open end wrench, tighten sensor clamp nut.

NOTE: It is not necessary to put large amounts of torque on this nut since a pressure seal is not necessary. Approximately 5 to 10 ft. lbs. is sufficient.

7. Now inspect flushness of diaphragm with inside surface of chamber. This can be accomplished visually in most cases.

If the diaphragm extends too deeply into the chamber, select a thicker spacer and repeat mounting procedure.

If the diaphragm is too deeply recessed, select a thinner spacer and remount.

Once the proper thickness is found for perfect flushness, the sensor may be removed and reinstalled using this same spacer and the proper depth will be achieved each time.

NOTE: For best accuracy of results, use same charge amplifier for calibration and for actual operation. Use long TC for calibration, medium or short TC for best drift free operation.

4.0 POLARITY

Polarity of the Model 117B is negative i.e., the charge output is negative for increasing pressure input, making it compatible with inverting type charge amplifiers.

5.0 CALIBRATION

Calibration of the Models 117B is facilitated by a calibration adaptor which exactly matches the chamber dimensions of the cartridge under test. An actual cartridge case is hydraulically pressurized with reference pressure to obtain a point-by-point sensor calibration.

These calibration adaptors can be fabricated by the user or can be purchased from PCB as our Model 090B calibration adaptor. Simply specify caliber and longitudinal location of sensor.

For most rimfire applications, the sensor is located .25 inches forward of the boltface.

For center fire cartridges a location .175 inches back from the cartridge shoulder is preferred. Consult PCB for recommendations on sensor locations if questions arise.

Since most cartridge cases are tapered and diameter is dependent upon longitudinal location, this location may not be changed after the sensor is fabricated since it is essential for proper operation that the sensor curvature exactly match chamber curvature.

**OPERATION MANUAL FOR
CONFORMAL BALLISTICS PRESSURE SENSOR
Series 117B**

5.1 LOW-END NONLINEARITY

It will be noticed during calibration, especially with metallic cartridges, that a certain amount of pressure is necessary before linear output is attained from the conformal sensor.

This is due to the fact that since the cartridge cases are made nominally smaller in diameter than the chamber to allow easy insertion and extraction, the case must be expanded slightly by the internal pressure before force can be transmitted to the sensor.

See the enclosed guide "An Improved Technique for Utilization of Conformal Ballistics Sensor Calibration Data" for methods of dealing with this topic.

6.0 MAINTENANCE

It is essential for normal operation of the Model 117B that the insulation resistance be maintained above 10^{12} ohms. If insulation resistance should deteriorate, wipe connector with clean cloth or paper wipe dipped in a solvent compatible with Teflon[®] such as isopropyl alcohol, then bake in oven at 250°F for ½ hour.

OPERATION MANUAL FOR
CONFORMAL BALLISTICS PRESSURE SENSOR
Series 117B

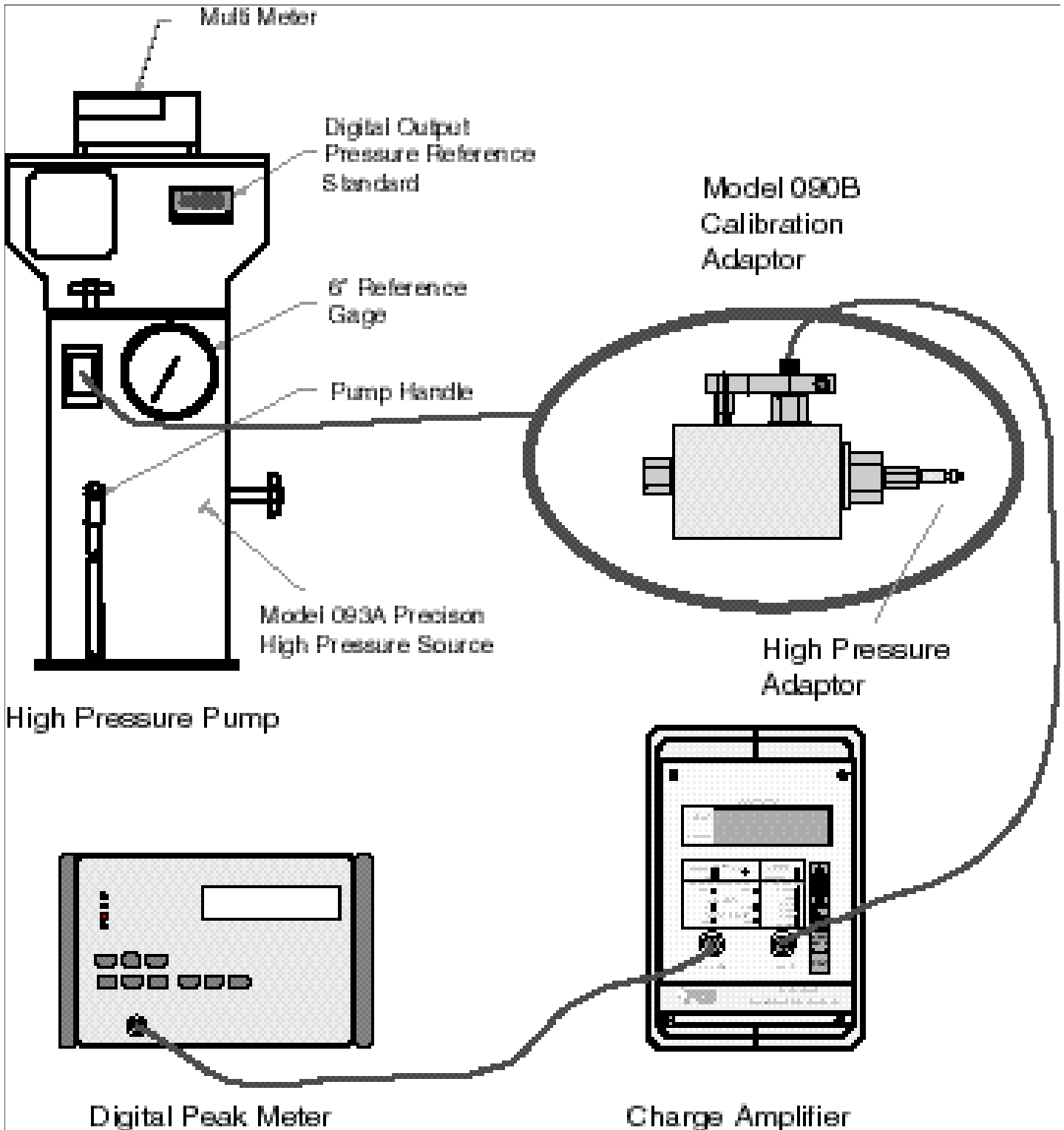

OPERATION MANUAL FOR
CONFORMAL BALLISTICS PRESSURE SENSOR
Series 117B

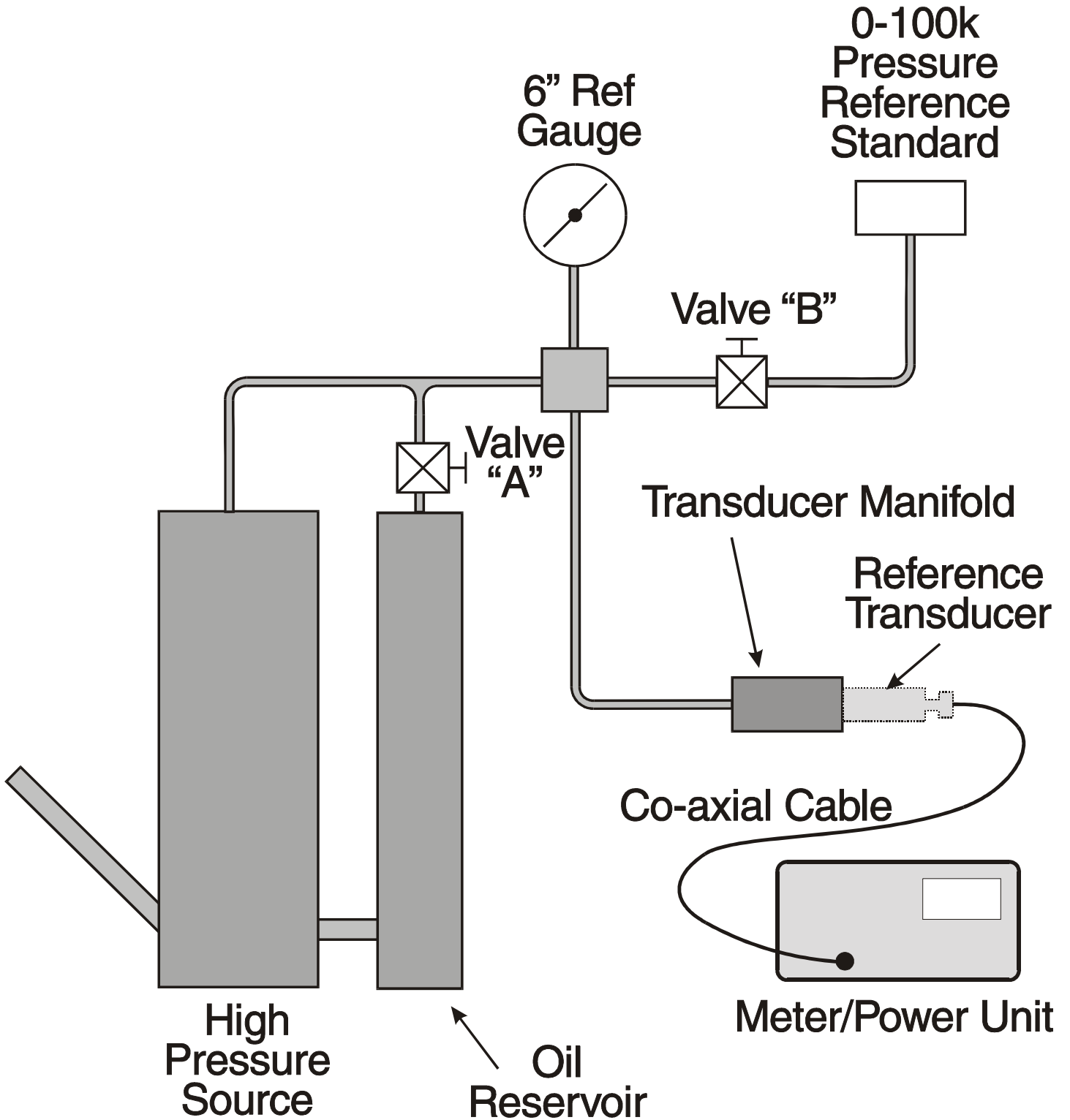

Model Number
117B-40K

CHARGE OUTPUT PRESSURE SENSOR

Revision: T
ECN #: 55204

Performance

	ENGLISH	SI	
Sensitivity(± 20 %)(for straight oil)	0.110 pC/psi	0.016 pC/kPa	[1][2]
Measurement Range	10 to 35 kpsi	68,950 to 241,300 kPa	[3]
Maximum Pressure	40 kpsi	275,800 kPa	
Resonant Frequency	≥ 300 kHz	≥ 300 kHz	
Rise Time(Reflected)	≤ 2 μ sec	≤ 2 μ sec	
Non-Linearity	≤ 2 % FS	≤ 2 % FS	

Environmental

Acceleration Sensitivity	.02 psi/g	.014 kPa/(m/s ²)	[4]
Temperature Range(Operating)	-100 to +400 °F	-73 to +204 °C	
Temperature Coefficient of Sensitivity	≤ .03 %/°F	≤ .054 %/°C	
Maximum Flash Temperature	3,000 °F	1,650 °C	
Maximum Vibration	1,000 g pk	9,810 m/s ² pk	
Maximum Shock	5,000 g pk	49,050 m/s ² pk	

Electrical

Output Polarity(Positive Pressure)	Negative	Negative	
Capacitance	5 pF	5 pF	[4]
Insulation Resistance(at room temp)	≥ 10 ¹² Ohm	≥ 10 ¹² Ohm	

Physical

Housing Material	17-4 Stainless Steel	17-4 Stainless Steel	
Diaphragm	17-4 Stainless Steel	17-4 Stainless Steel	
Sealing	Epoxy	Epoxy	
Electrical Connector	10-32 Coaxial Jack	10-32 Coaxial Jack	
Weight	.35 oz	10 gm	

OPTIONAL VERSIONS

Optional versions have identical specifications and accessories as listed for the standard model except where noted below. More than one option may be used.

M - Metric Mount

NOTES:

- [1] Actual slope is dependent upon material properties of cartridge case.
- [2] For conformal cal. sensitivity will be ±40%.
- [3] Calibrated range to 35,000 psi.
- [4] Typical.
- [5] See PCB Declaration of Conformance PS158 for details.

SUPPLIED ACCESSORIES:

Model 045B Alignment Guide
 Model 065A27 Spacer set 0.196" ID
 Model PCS-2 Calibration of dynamic pressure sensors to full scale measurement range up to 100k psi

OPTIONAL ACCESSORIES:

Model PCS-4 Conformal calibration of 117 series sensor with corresponding 090 series adaptor; using customer supplied cartridge casings (unfired / unprimed)

Entered: ND	Engineer: RPF	Sales: RWM	Approved: RPF	Spec Number:
Date: 09/18/2024	Date: 09/18/2024	Date: 09/18/2024	Date: 09/18/2024	117-2660-80



All specifications are at room temperature unless otherwise specified.
 In the interest of constant product improvement, we reserve the right to change specifications without notice.
 ICP® is a registered trademark of PCB Piezotronics, Inc.

PCB PIEZOTRONICS Phone: 716-684-0001
 AN AMPHENOL COMPANY Fax: 716-684-0987
 E-Mail: info@pcb.com

3425 Walden Avenue, Depew, NY 14043

117-2660-90

PCB Piezotronics Inc. claims proprietary rights in the information disclosed hereon. Neither it nor any reproduction thereof will be disclosed to others without the written consent of PCB Piezotronics Inc.

REVISIONS		
REV	DESCRIPTION	DIN
E	UPDATED ALIGNMENT GUIDE	39992

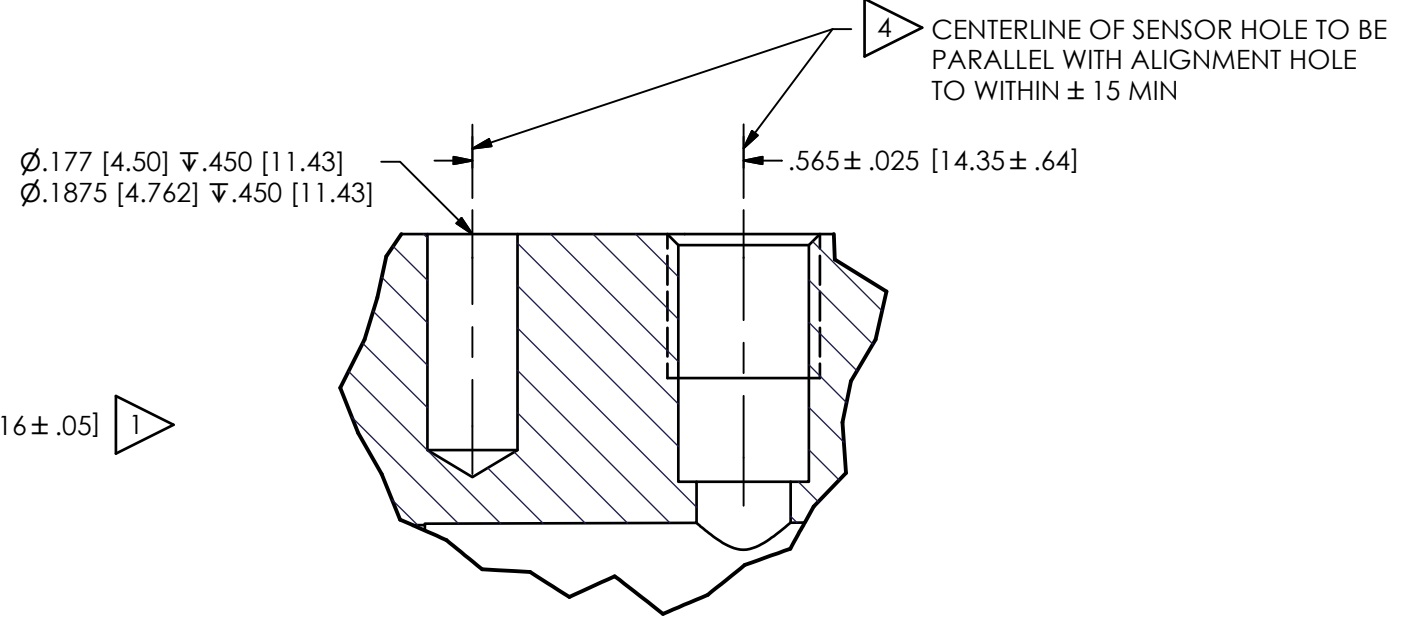
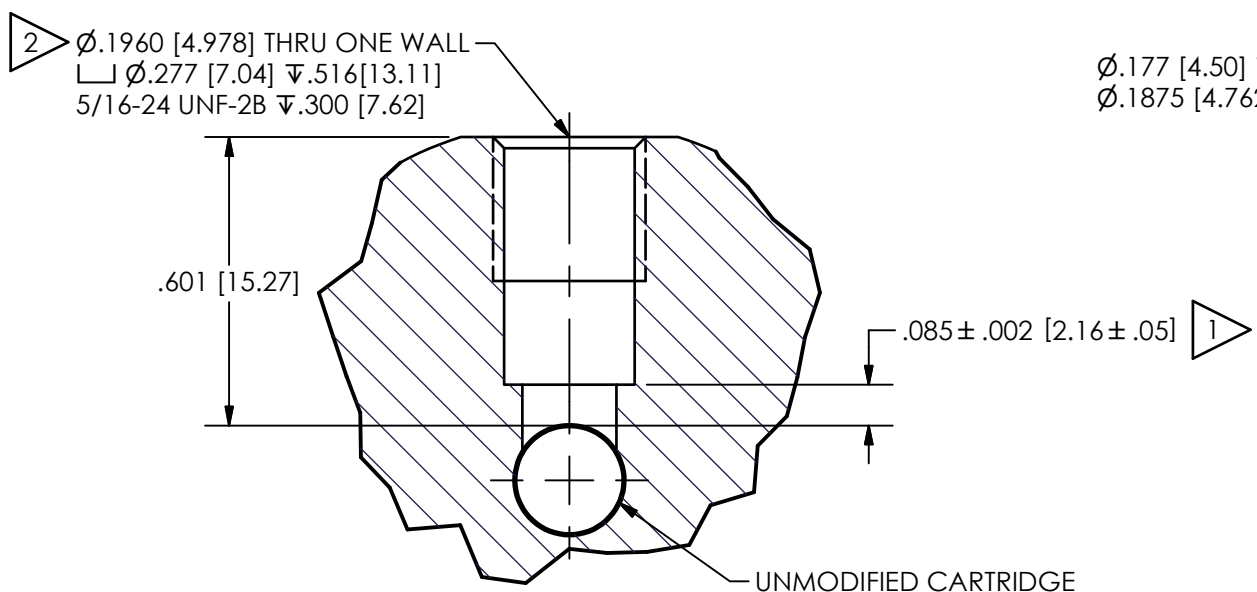
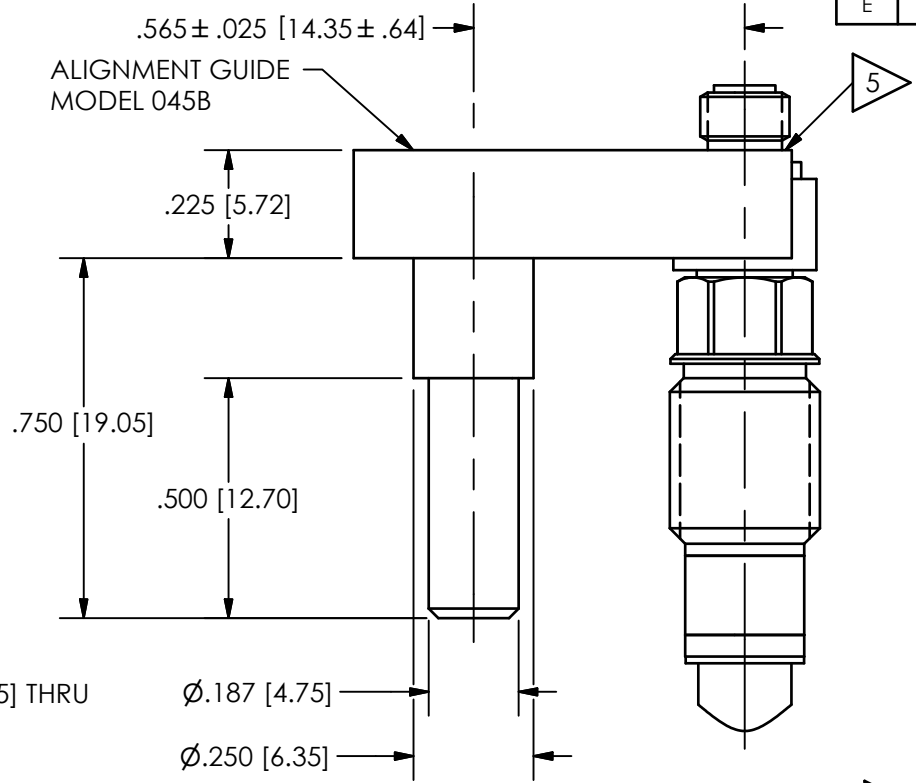
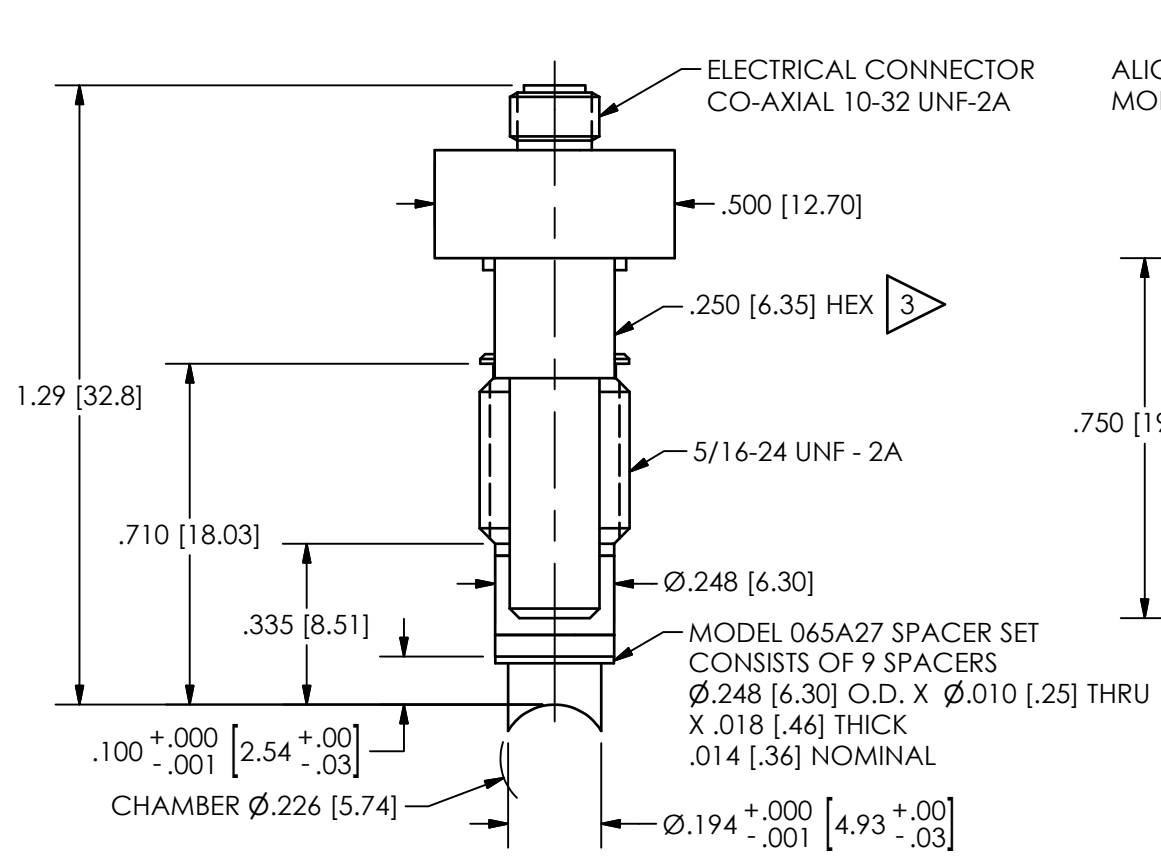

- 5 LOCATE YELLOW DOT TOWARD CASE MOUTH.
- 4 ALIGNMENT HOLE MY BE LOCATED EITHER FOR OR AFT OF SENSOR MOUNTING HOLE.
- 3 MOUNTING TORQUE ON .250 [6.35] HEX: 2-5 FT LBS [2.7-6.8 NEWTON METERS].
- 2 CENTERLINE OF Ø.1960 [4.98] HOLE MUST INTERSECT CENTERLINE OF CHAMBER BORE WITHIN .001 [.23].
- 1 HOLD THIS DIMENSION TO OBTAIN FLUSH MOUNT.

UNLESS OTHERWISE SPECIFIED TOLERANCES ARE:		DRAWN		CHECKED		ENGINEER	
DIMENSIONS IN INCHES	DIMENSIONS IN MILLIMETERS [IN BRACKETS]	JDM	11/17/14	JDM	11/17/14	SMB	11/17/14
DECIMALS XX ±.01 XXX ±.005	DECIMALS X ±.03 XX ±.013	TITLE					
ANGLES ± 2 DEGREES	ANGLES ± 2 DEGREES	INSTALLATION DRAWING MODEL 117B66 CONFORMAL BALLISTICS SENSOR					
FILLETS AND RADII .003 - .005	FILLETS AND RADII 0.07 - 0.13	CODE IDENT. NO. 52681		DWG. NO. 117-2660-90		3425 WALDEN AVE. DEPEW, NY 14043 (716) 684-0001 E-MAIL: sales@pcb.com	
		SCALE: 2.5X		SHEET 1 OF 1			

