



Model 685A08

Mechanical Vibration Switch

Installation and Operating Manual

**For assistance with the operation of this product,
contact PCB Piezotronics, Inc.**

**Toll-free: 800-959-4464
24-hour SensorLine: 716-684-0001
Fax: 716-684-3823
E-mail: imi@pcb.com
Web: www.imi-sensors.com**



Repair and Maintenance

PCB guarantees Total Customer Satisfaction through its “Lifetime Warranty Plus” on all Platinum Stock Products sold by PCB and through its limited warranties on all other PCB Stock, Standard and Special products. Due to the sophisticated nature of our sensors and associated instrumentation, **field servicing and repair is not recommended and, if attempted, will void the factory warranty.**

Beyond routine calibration and battery replacements where applicable, our products require no user maintenance. Clean electrical connectors, housings, and mounting surfaces with solutions and techniques that will not harm the material of construction. Observe caution when using liquids near devices that are not hermetically sealed. Such devices should only be wiped with a dampened cloth—never saturated or submerged.

In the event that equipment becomes damaged or ceases to operate, our Application Engineers are here to support your troubleshooting efforts 24 hours a day, 7 days a week. Call or email with model and serial number as well as a brief description of the problem.

Calibration

Routine calibration of sensors and associated instrumentation is necessary to maintain measurement accuracy. We recommend calibrating on an annual basis, after exposure to any extreme environmental influence, or prior to any critical test.

PCB Piezotronics is an ISO-9001 certified company whose calibration services are accredited by A2LA to ISO/IEC 17025, with full traceability to SI through N.I.S.T. In addition to our standard calibration services, we also offer specialized tests, including: sensitivity at elevated or cryogenic temperatures, phase response, extended high or low frequency response, extended range, leak testing, hydrostatic pressure testing, and others. For more information, contact your local PCB Piezotronics distributor, sales representative, or factory customer service representative.

Returning Equipment

If factory repair is required, our representatives will provide you with a Return Material Authorization (RMA) number, which we use to reference any information you have already provided and expedite the repair process. This number should be clearly marked on the outside of all returned package(s) and on any packing list(s) accompanying the shipment.

Contact Information

PCB Piezotronics, Inc.
3425 Walden Ave.
Depew, NY14043 USA
Toll-free: (800) 828-8840
24-hour SensorLine: (716) 684-0001
General inquiries: info@pcb.com
Repair inquiries: rma@pcb.com

For a complete list of distributors, global offices and sales representatives, visit our website, www.pcb.com.

Safety Considerations

This product is intended for use by qualified personnel who recognize shock hazards and are familiar with the precautions required to avoid injury. While our equipment is designed with user safety in mind, the protection provided by the equipment may be impaired if equipment is used in a manner not specified by this manual.

Discontinue use and contact our 24-Hour Sensorline if:

- Assistance is needed to safely operate equipment
- Damage is visible or suspected
- Equipment fails or malfunctions

For complete equipment ratings, refer to the enclosed specification sheet for your product.

Definition of Terms and Symbols

The following symbols may be used in this manual:



DANGER

Indicates an immediate hazardous situation, which, if not avoided, may result in death or serious injury.

**CAUTION**

Refers to hazards that could damage the instrument.

**NOTE**

Indicates tips, recommendations and important information. The notes simplify processes and contain additional information on particular operating steps.

The following symbols may be found on the equipment described in this manual:



This symbol on the unit indicates that high voltage may be present. Use standard safety precautions to avoid personal contact with this voltage.



This symbol on the unit indicates that the user should refer to the operating instructions located in the manual.



This symbol indicates safety, earth ground.



PCB工业监视和测量设备 - 中国RoHS2公布表

PCB Industrial Monitoring and Measuring Equipment - China RoHS 2 Disclosure Table

部件名称	有害物质					
	铅 (Pb)	汞 (Hg)	镉 (Cd)	六价铬 (Cr(VI))	多溴联苯 (PBB)	多溴二苯醚 (PBDE)
住房	0	0	0	0	0	0
PCB板	X	0	0	0	0	0
电气连接器	0	0	0	0	0	0
压电晶体	X	0	0	0	0	0
环氧	0	0	0	0	0	0
铁氟龙	0	0	0	0	0	0
电子	0	0	0	0	0	0
厚膜基板	0	0	X	0	0	0
电线	0	0	0	0	0	0
电缆	X	0	0	0	0	0
塑料	0	0	0	0	0	0
焊接	X	0	0	0	0	0
铜合金/黄铜	X	0	0	0	0	0
本表格依据 SJ/T 11364 的规定编制。						
0：表示该有害物质在该部件所有均质材料中的含量均在 GB/T 26572 规定的限量要求以下。						
X：表示该有害物质至少在该部件的某一均质材料中的含量超出 GB/T 26572 规定的限量要求。						
铅是欧洲RoHS指令2011/65/ EU附件三和附件四目前由于允许的豁免。						

CHINA RoHS COMPLIANCE

Component Name	Hazardous Substances					
	Lead (Pb)	Mercury (Hg)	Cadmium (Cd)	Chromium VI Compounds (Cr(VI))	Polybrominated Biphenyls (PBB)	Polybrominated Diphenyl Ethers (PBDE)
Housing	O	O	O	O	O	O
PCB Board	X	O	O	O	O	O
Electrical Connectors	O	O	O	O	O	O
Piezoelectric Crystals	X	O	O	O	O	O
Epoxy	O	O	O	O	O	O
Teflon	O	O	O	O	O	O
Electronics	O	O	O	O	O	O
Thick Film Substrate	O	O	X	O	O	O
Wires	O	O	O	O	O	O
Cables	X	O	O	O	O	O
Plastic	O	O	O	O	O	O
Solder	X	O	O	O	O	O
Copper Alloy/Brass	X	O	O	O	O	O

This table is prepared in accordance with the provisions of SJ/T 11364.

O: Indicates that said hazardous substance contained in all of the homogeneous materials for this part is below the limit requirement of GB/T 26572.

X: Indicates that said hazardous substance contained in at least one of the homogeneous materials for this part is above the limit requirement of GB/T 26572.

Lead is present due to allowed exemption in Annex III or Annex IV of the European RoHS Directive 2011/65/EU.

Model 685A08 Mechanical Vibration Switch



Operating Guide

3425 Walden Avenue, Depew, New York 14043-2495

Phone (716) 684-0003

Fax (716) 684-3823

Toll Free Line 1-800-959-4IMI

MANUAL NUMBER: 34377
MANUAL REVISION: NR
ECN NUMBER:

Table of Contents

<i>Introduction.....</i>	<i>Page 3</i>
<i>General Features</i>	
<i>Specifications</i>	<i>Page 4</i>
<i>Dimension Drawing</i>	<i>Page 5</i>
<i>Installation</i>	<i>Page 6</i>
<i>Typical Mounting Locations</i>	<i>Page 7</i>
<i>Internal Switches</i>	<i>Page 8</i>
<i>Electrical.....</i>	<i>Pages 9-10</i>
<i>Sensitivity Adjustment</i>	<i>Page 11</i>

Introduction

The Model 685AX8 Series Mechanical Vibration Switches are shock sensitive mechanisms for shutdown of engine or electric motor powered equipment. These switches use a magnetic latch to ensure reliable operation. Pushing the reset button moves the tripping latch into a magnetically held position. A shock/vibration will move the magnet beyond this holding position, thus freeing the spring loaded tripping latch to transfer the contacts and shutdown the machinery.

General Features

- Designed to Detect Shock/Vibration in 3-Planes of Motion
- Fully Adjustable
- Includes Magnetic Latching Feature
- Accommodates normally open (NO) and normally closed (NC) wiring schemes.
- Manual Reset Button on all models
- Remote Reset option available on 685A18 (350mA @ 24VDC) or 685A28 (350mA @ 115VAC.)
- Designed for use in hazardous locations. (Class I Div 1 Groups C & D)
- Top cover is threaded for easy access to wiring terminals.

Specifications

- **Sensing Geometry:** Inertial Element
- **Vibration Range:** 0-7g-peak
- **Alarm function Select:** Latch
- **Alarm Relay:** 5A Form C 480VAC, 2A Resistive, 1A Inductive @ 30VDC
- **Operating Temperature Range:** -40 to 140°F (-40 to 60°C)
- **Ingress Protection:** NEMA 7/IP50
- **Case Dimension W x H x D:** 6.38 x 4.88 x 5.63in. (162 x 124 x 143mm)
- **Weight:** 4.5 lbs. (2.04 kg)
- **Case Material:** Aluminum Alloy
- **Input/Output Electrical Connectors:** Removable Screw Terminals
- **Screw Terminal Wire Size:** ... 14 AWG (2.5 mm²)
- **Conduit Hole:** 1/2" Threaded NPT Female
- **Mounting Holes:** (4) 0.38"
- **Alarm Setpoint:** Control Screw
- **Reset Function:** Pushbutton Switch (685A08, A18, & A28)
 - Remote Reset, 350mA @ 24VDC (685A18)
 - Remote Reset, 350mA @ 115VAC (685A28)

The Model 685AX8 is designed to be mounted directly on the equipment to be monitored via integral mounting holes.

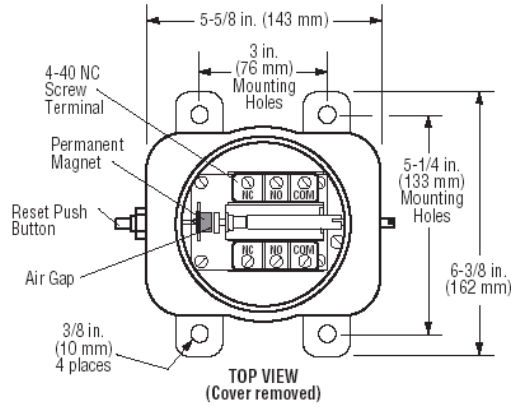

685A08 Dimension Drawing

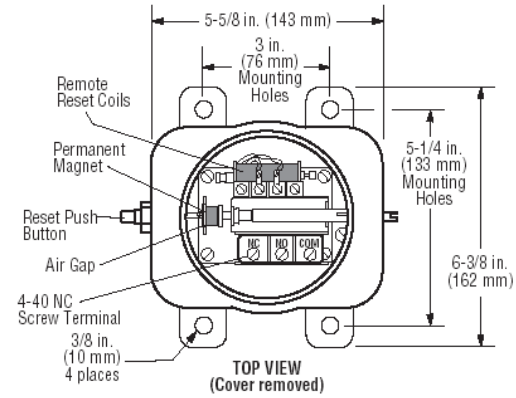

685A18/A28 Dimension Drawing

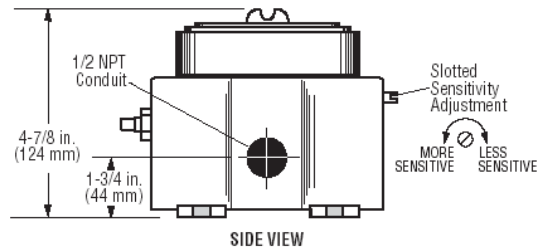
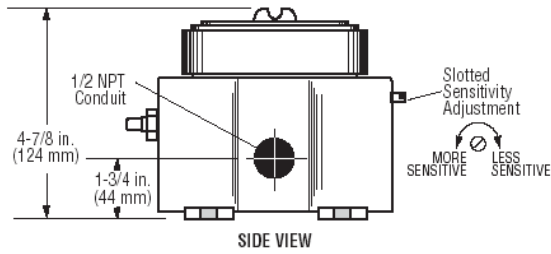

WARNING

AC and DC input signals and power supply voltages could be hazardous. DO NOT connect live wires to screw terminal plugs, and DO NOT insert, remove, or handle screw terminal plugs with live wires connected.

Installation

WARNING!!!

BEFORE BEGINNING INSTALLATION OF THIS IMI PRODUCT:

- ✓ Stop the machine.

- ✓ Disconnect all electrical power to the machine.
- ✓ Make sure the machine cannot operate during installation.
- ✓ Follow all safety warnings of the machine manufacturer.
- ✓ Read and follow all installation instructions.

The 685AX8 Series vibration switches are sensitive to shock and vibration in all three planes of motion - up/down, front/back and side/side. Side/side (in the same plane as the reset pushbutton) is the most sensitive. For maximum sensitivity mount the unit so that the side with the reset button is in-line with the direction of rotation of the machine. (See Dimension Drawing on page 5 for sensitivity adjustment location.)

The 685AX8 must be firmly attached/mounted to the machine so that all mounting surfaces are in rigid contact with the mounting surface of the machine. For best results, mount the instrument in-line with the direction of rotating shafts and/or near bearings. In other words, the reset push button should be mounted pointing into the direction of shaft rotation (see page 7). It may be necessary to provide a mounting plate or bracket to attach the 685AX8 to the machine. The mounting bracket should be thick enough to prevent induced acceleration/vibration upon the 685AX8. Typically 1/2 in. (13mm) thick plate is sufficient. See illustrations on page 7 for typical mounting locations.

CAUTION: A dust boot is provided on the reset pushbutton for all series to prevent moisture or dust intrusion. The sensitivity adjustment for model 685AX8 is not sealed; therefore, mounting orientation should be on a horizontal plane or with the sensitivity adjustment pointing down.

WARNING: STOP THE MACHINE AND DISCONNECT ALL ELECTRICAL POWER BEFORE BEGINNING INSTALLATION.

- 1) Firmly secure the unit to the equipment using the base foot mount.
For oil well pump jacks, attach the 685AX8 to the Sampson post or walking beam. See Typical Mounting Locations page 7.
- 2) Make the necessary electrical connections to the vibration switch. See Internal Switches, page 8 for electrical terminal locations and page 9 & 10 for typical wiring diagrams. **DO NOT EXCEED VOLTAGE OR CURRENT RATINGS OF THE CONTACTS.** Follow appropriate electrical codes/methods when making electrical connections. Be sure that the run of electrical cable is secured to the machine and is well insulated from electrical shorting. Use of conduit is recommended.

NOTE: If the electrical cable crosses a pivot point such as at the pivot of the walking beam, be sure to allow enough slack in the cable so that no stress is placed on the cable when the beam moves.

If conduit is not used for the entire length of wiring, conduit should be used from the electrical supply box to a height above ground level that prevents damage to the exposed cable from the elements, rodents, etc. or as otherwise required by applicable electrical codes. If conduit is not attached directly to the 685AX8 switch, use a strain relief bushing and a weatherproof cap on the exposed end of the conduit. A “drip loop” should be provided in the cable to prevent moisture from draining down the cable into the conduit should the weatherproof cap fail.

TYPICAL MOUNTING LOCATIONS

2-Throw Balance-Opposed Compressor

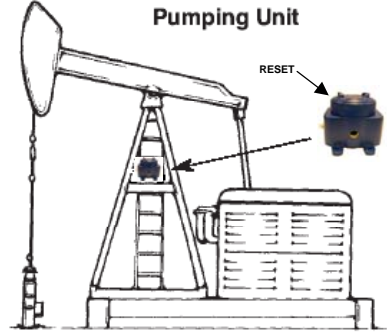
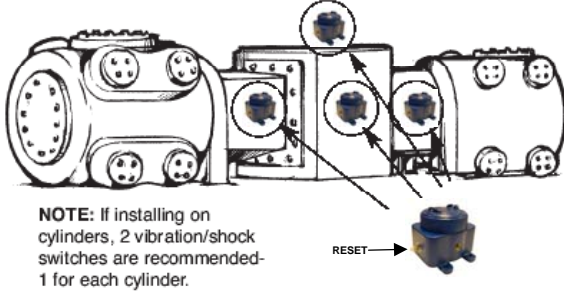

Engine and Vertical Shaft Pump

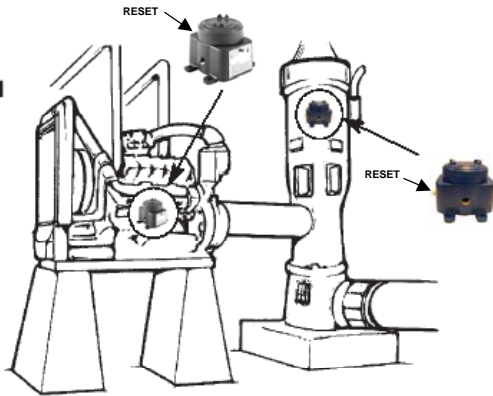

"Y" Type Reciprocating Compressor

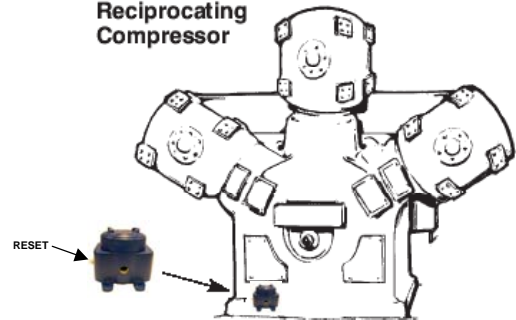

Generator Sets

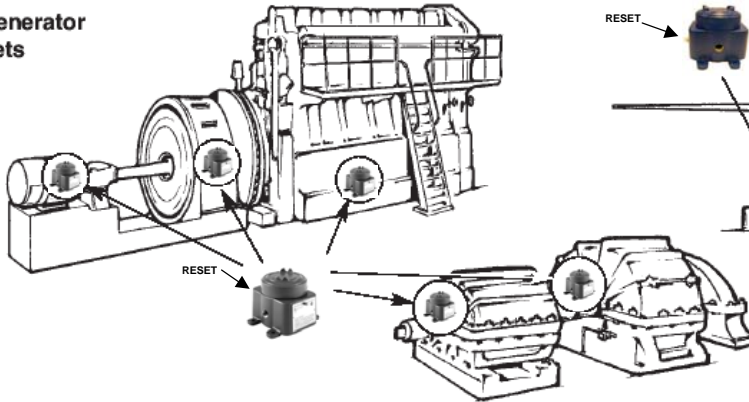

Cooling Tower Fan or Heat Exchanger

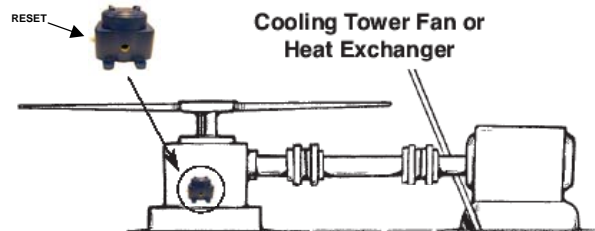

Engine Compressor

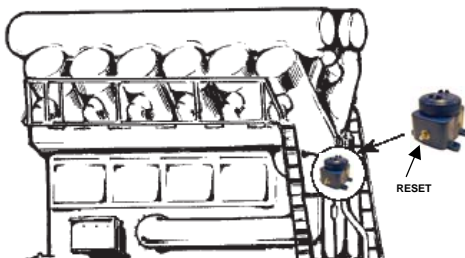

Turbine Centrifugal Compressor

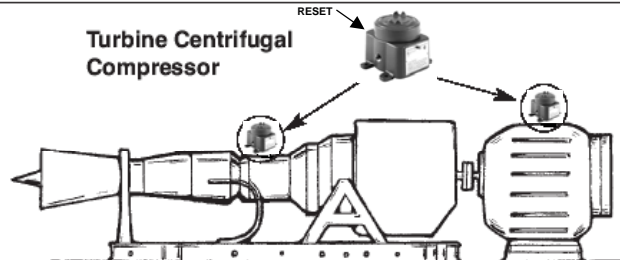

Internal Switches

The 685A08 uses 2-SPDT switch terminals with removable screws for all connections (see below.)

685A08 Screw Connections

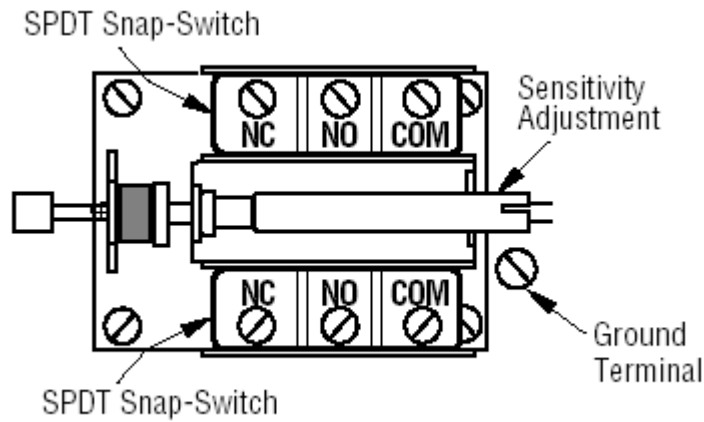

The 685A18 and 685A28 use 1-SPDT switch terminals with removable screws for all connections (see below.)

685A18 & A28 Screw Connections

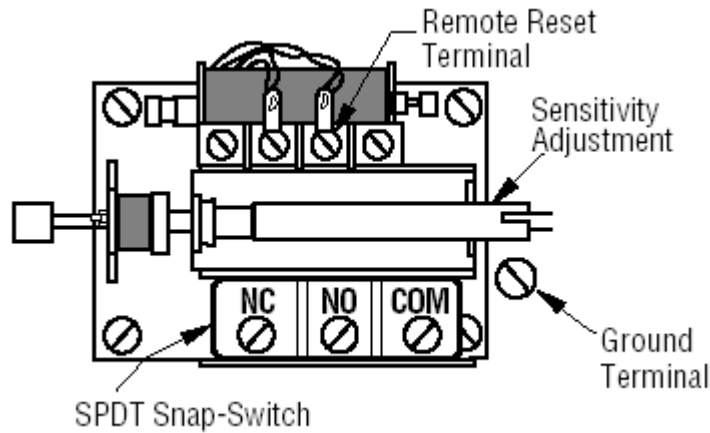

Screw Connections:

NO Normally Open
COM Common
NC Normally Closed
Internal ground screw

ELECTRICAL



WARNING: REMOVE POWER BEFORE OPENING THE UNIT (ACCESS DOOR). STOP THE MACHINE AND DISCONNECT ALL ELECTRICAL POWER BEFORE BEGINNING THE WIRING OPERATION. IT IS YOUR RESPONSIBILITY TO HAVE A QUALIFIED PERSON INSTALL AND WIRE THE UNIT, AND MAKE SURE IT CONFORMS WITH NEC AND APPLICABLE CODES.

685A08

Typical Wiring Diagram for Single or Dual CD Ignitions

2-SPDT Switch (DPDT)

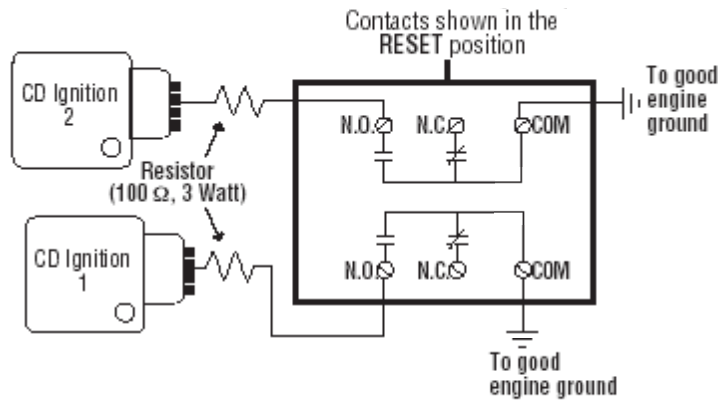

685A18/A28

Typical Wiring Diagram for Single CD Ignitions

SPDT Switch

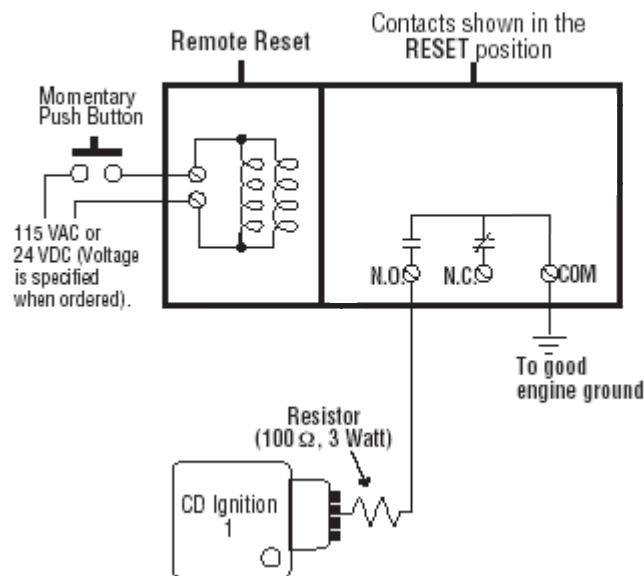

685A08, A18, & A28

Typical Wiring Diagram for Electric Motors

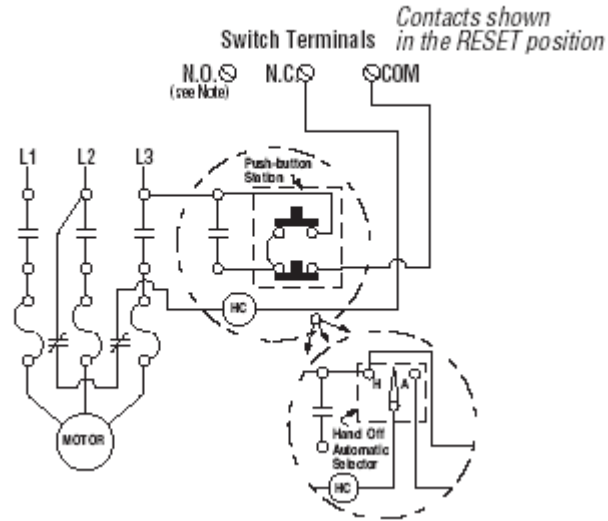

685A08, A18, & A28

Typical Wiring Diagram for Distributor Ignition or Diesel

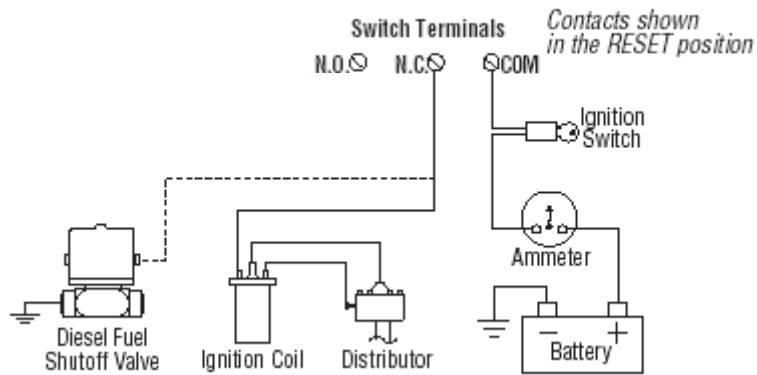

Sensitivity Adjustment

WARNING: REMOVE ALL POWER BEFORE OPENING THE ENCLOSURE. IT IS YOUR RESPONSIBILITY TO HAVE A QUALIFIED PERSON PERFORM ADJUSTMENTS AND MAKE SURE IT CONFORMS TO NEC AND LOCAL CODES. DO NOT ADJUST SENSITIVITY WHILE THE MACHINE IS RUNNING. STAND CLEAR OF THE MACHINE AT ALL TIMES WHEN IT IS OPERATING.

The 685AX8 Series covers a wide range of sensitivity and needs to be adjusted to the specific piece of machinery on which it is installed. After the switch has been installed in a satisfactory location (see page 6) the sensitivity adjustment will be increased or decreased so that the switch does not trip during start-up or under normal operating conditions.

This is typically done as follows:

- 1) **REPLACE ALL COVERS, LIDS, AND ELECTRICAL ENCLOSURES.**
- 2) Press the reset push button (see **Figure 1**) to engage the magnetic latch. Be sure that the reset button remains depressed. If it does not remain depressed, turn sensitivity adjustment screw (see **Figure 2**) clockwise until it stops, turn it ¼ turn counterclockwise, and press the reset button again.



Figure 1



Figure 2

- 3) Start the machine.
- 4) If the instrument trips on start-up, allow the machine to stop. Turn the sensitivity adjustment 1/4 turn clockwise. Depress the reset button and restart the machine. Repeat this process until the unit does not trip on start-up.
- 5) If the instrument does NOT trip on start-up, stop the machine. Turn the sensitivity adjustment screw 1/4 turn counter-clockwise. Repeat the start-up/stop process until the instrument trips on start-up. Turn the sensitivity adjustment screw 1/4 turn clockwise (less sensitive). Restart the machine to verify that the instrument will not trip on start-up.
- 6) Verify that the unit will trip when abnormal shock/vibration exists.

Model Number
685AX8

MECHANICAL VIBRATION SWITCH SPECIFICATIONS

Revision: NR
ECN #:

PERFORMANCE

Vibration Range
Frequency Response

ENGLISH

0 to 7g peak
0-6000cpm

SI

0 to 68.7 m/s² peak
0-100Hz

ELECTRICAL

Alarm Function
Alarm Relay (SPDT)

Latch
5A Form C 480VAC/2A Resistive,
1A Inductive @ 30VDC

Latch
5A Form C 480VAC/2A Resistive,
1A Inductive @ 30VDC

ENVIRONMENTAL

Operating Temperature Range
Ingress Protection

-40 to +140°F
IP50

-40 to -60°C
IP50

PHYSICAL

Size (Width x Height x Depth)
Conduit Hole
Weight
Mounting Thread
Mounting Holes (4)
Sensing Element
Sensing Geometry
Housing Material
Electrical Connector
Screw Terminal Wire Size
Rating

6.38 in x 4.88 in x 5.63 in
1/2-14 NPT
4.5 lbs
Thru Hole
0.38 in
Magnet
Inertial Element
Aluminum Alloy
Removable Screw Terminals
14 AWG
Explosion Proof

162 mm x 124 mm x 143 mm
N/A
2.04 kg
Thru Hole
10 mm
Magnet
Inertial Element
Aluminum Alloy
Removable Screw Terminals
2.5 mm²
Flame Proof

INDICATOR/CONTROLS

Alarm Setpoint
Reset Function

Control Screw
Pushbutton Switch

Control Screw
Pushbutton Switch

OPTIONAL VERSIONS

Optional versions have identical specifications and accessories as listed for the standard model except where noted below. More than one option may be used.

685AX8

- 0 No remote reset (base model)
- 1 Remote reset, 350 mA @ 24VDC
- 2 Remote reset, 350 mA @ 115VAC

NOTES:

- Hazardous Area Certification**
[1] Class I, Div. 1, Group C & D.
[2] 1697235
[3] 516U

[1]



[1] [2]



[1] [3]

All specifications are at room temperature unless otherwise specified.

ICP® is a registered trademark of PCB Group, Inc.

In the interest of constant product improvement, we reserve the right to change specifications without notice.

Form DD030 Rev.F 2/23/99

Drawn: <i>St</i>	Engineer: <i>AS</i>	Sales: <i>SG</i>	Approved: <i>NS</i>	Spec Number:
Date: <i>9-18-06</i>	Date: <i>9/18/06</i>	Date: <i>9/20/06</i>	Date: <i>9/20/06</i>	33523



3425 Walden Avenue, Depew, NY 14043

800-959-4464

Fax (716) 684-3823

E-Mail: imisales@pcb.com

34367

PCB Piezotronics Inc. claims proprietary rights in the information disclosed herein. Neither it nor any reproduction thereof will be disclosed to others without the written consent of PCB Piezotronics Inc.

APPLICATION

NEXT ASS'Y	USED ON	VAR

REVISIONS

REV	DESCRIPTION	ECN	APP'D
NR	RELEASED TO DRAFTING		ECB 11/2/06

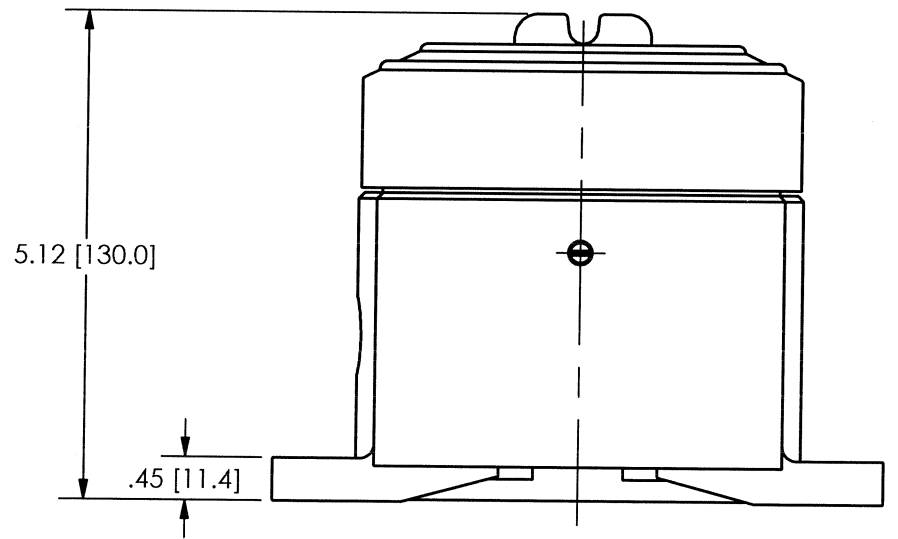
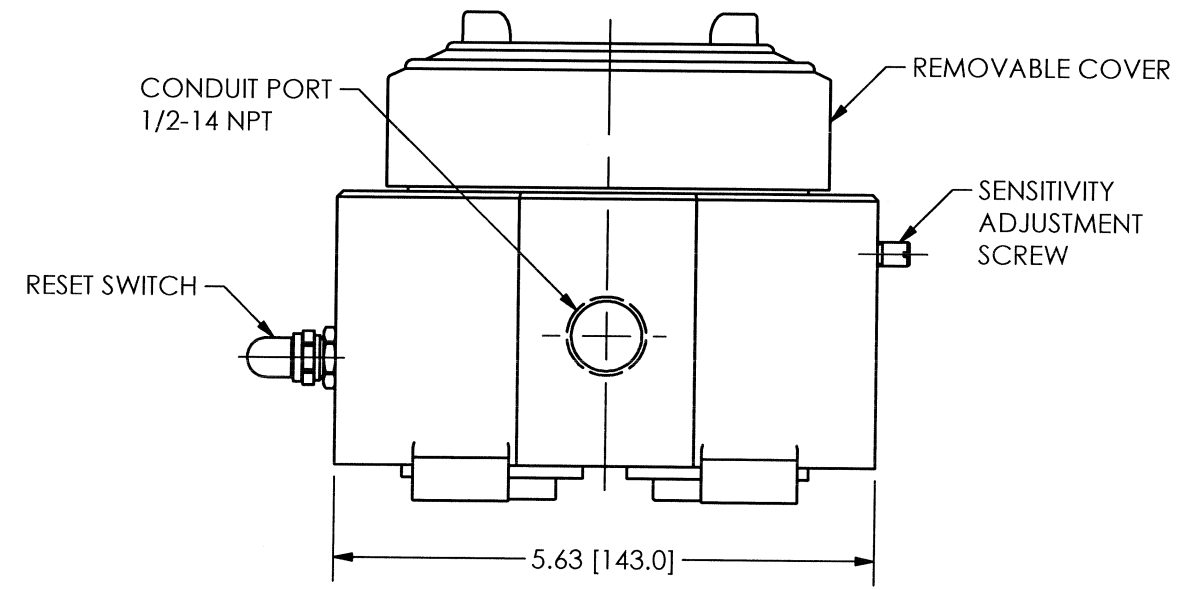
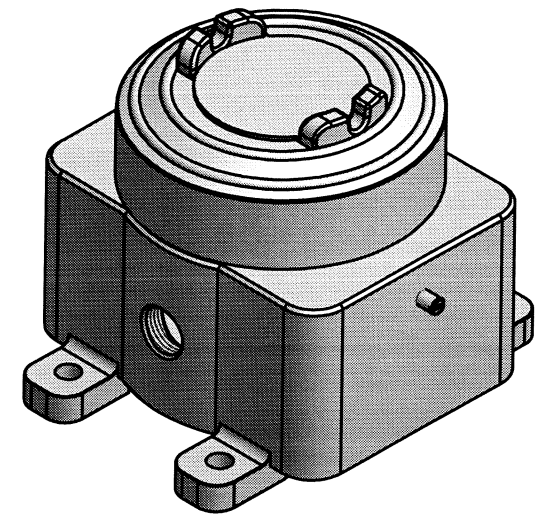
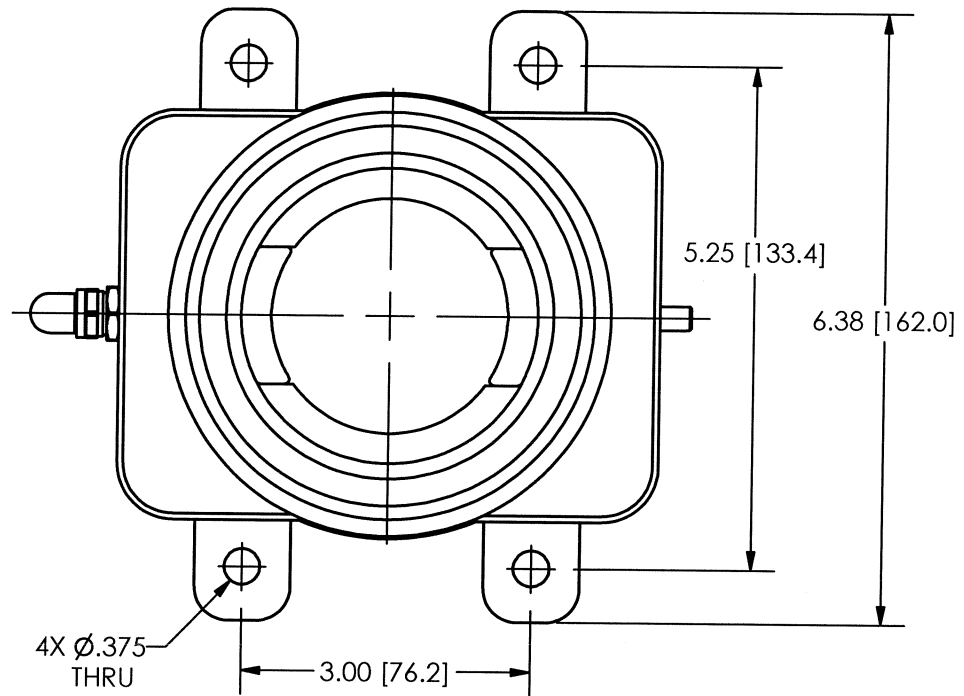

UNLESS OTHERWISE SPECIFIED TOLERANCES ARE:		DRAWN	CHK'D	APP'D	MFG	ENGR	SALES	PCB PIEZOTRONICS™	
DIMENSIONS IN INCHES	DIMENSIONS IN MILLIMETERS [IN BRACKETS]	<i>mm</i>	<i>ECB</i>	<i>mm</i>	<i>11/3/06</i>	<i>LAB</i>	<i>11/2/06</i>	3425 WALDEN AVE. DEPEW, NY 14043	
DECIMALS XX ± .03	DECIMALS X ± 0.8							(716) 684-0001 E-MAIL: sales@pcb.com	
XXX ± .010	XX ± 0.25							CODE IDENT. NO. 52681	DWG. NO. 34367
ANGLES ± 2 DEGREES	ANGLES ± 2 DEGREES							SCALE: .5X	SHEET 1 OF 1
FILLETS AND RADII .003 - .005	FILLETS AND RADII [0.07 - 0.13]	TITLE			OUTLINE DRAWING MODEL 685AX8 SERIES MECHANICAL VIBRATION SWITCH				



CSA INTERNATIONAL

Certificate of Compliance

Certificate: 1697235

Master Contract: 151230

Project: 1833514

Date Issued: 2006/10/23

Issued to: FW Murphy
P.O. Box 470248
Tulsa, OK 74147
USA
Attention: Phong Le

The products listed below are eligible to bear the CSA Mark shown with adjacent indicators 'C' and 'US'



Issued by:

E. Klier
Ernest Klier, P.Eng.

Authorized by: Patricia Pasemko, Operations Manager

Patricia Pasemko

PRODUCTS

CLASS 3218 86 - INDUSTRIAL CONTROL EQUIPMENT-Miscellaneous Apparatus - For Hazardous Locations-Certified to U.S. Standards

CLASS 3218 06 - INDUSTRIAL CONTROL EQUIPMENT - Miscellaneous Apparatus - For Hazardous Locations

Class I, Div.1, Groups C, D.

Vibration- shock detector switch Model VS-2-EX, 480Vac. max. 5A, or VS-2-EXR rated 24Vdc or 120 Vac nominal.

Note: This equipment can be listed under IMI SENSORS as manufacturer name and under model 685A08.

The 'C' and 'US' indicators adjacent to the CSA Mark signify that the product has been evaluated to the applicable CSA and ANSI/UL Standards, for use in Canada and the U.S., respectively. This 'US' indicator includes products eligible to bear the 'NRTL' indicator. NRTL, i.e. National Recognized Testing Laboratory, is a designation granted by the U.S. Occupational Safety and Health Administration (OSHA) to laboratories which have been recognized to perform certification to U.S. Standards.



Certificate: 1697235

Master Contract: 151230

Project: 1833514

Date Issued: 2006/10/23

APPLICABLE REQUIREMENTS

CSA Std C22.2 No. 30-1970 - Explosion-Proof Enclosures for Use in Class I Hazardous Locations

CSA Std C22.2 No. 142-M1987 - Process Control Equipment

UL Std No. 916 - Energy Management Equipment

UL Std No. 1203, Third Ed. - 2000 - Explosion-Proof and Dust-Ignition-Proof Electrical Equipment for Use in Hazardous (Classified) Locations



Supplement to Certificate of Compliance

Certificate: 1697235

Master Contract: 151230

The products listed, including the latest revision described below, are eligible to be marked in accordance with the referenced Certificate.

Product Certification History

Project	Date	Description
1833514	2006/10/23	Alternate Manufacturer Name
1697235	2005/12/09	Revised Construction

History

46306-1	May 29, 1980	Original Certification
---------	--------------	------------------------