



Model RHM240A01

Industrial dynamic strain sensor, ICP® quartz, 100 mV/microstrain, +/-50 microstrain range, M6 x 1 thd, RoHS compliant

Installation and Operating Manual

**For assistance with the operation of this product,
contact the PCB Piezotronics, Inc.**

**Toll-free: 716-684-0001
24-hour SensorLine: 716-684-0001
Fax: 716-684-0987
E-mail: info@pcb.com
Web: www.pcb.com**



Repair and Maintenance

PCB guarantees Total Customer Satisfaction through its “Lifetime Warranty Plus” on all Platinum Stock Products sold by PCB and through its limited warranties on all other PCB Stock, Standard and Special products. Due to the sophisticated nature of our sensors and associated instrumentation, **field servicing and repair is not recommended and, if attempted, will void the factory warranty.**

Beyond routine calibration and battery replacements where applicable, our products require no user maintenance. Clean electrical connectors, housings, and mounting surfaces with solutions and techniques that will not harm the material of construction. Observe caution when using liquids near devices that are not hermetically sealed. Such devices should only be wiped with a dampened cloth—never saturated or submerged.

In the event that equipment becomes damaged or ceases to operate, our Application Engineers are here to support your troubleshooting efforts 24 hours a day, 7 days a week. Call or email with model and serial number as well as a brief description of the problem.

Calibration

Routine calibration of sensors and associated instrumentation is necessary to maintain measurement accuracy. We recommend calibrating on an annual basis, after exposure to any extreme environmental influence, or prior to any critical test.

PCB Piezotronics is an ISO-9001 certified company whose calibration services are accredited by A2LA to ISO/IEC 17025, with full traceability to SI through N.I.S.T. In addition to our standard calibration services, we also offer specialized tests, including: sensitivity at elevated or cryogenic temperatures, phase response, extended high or low frequency response, extended range, leak testing, hydrostatic pressure testing, and others. For more information, contact your local PCB Piezotronics distributor, sales representative, or factory customer service representative.

Returning Equipment

If factory repair is required, our representatives will provide you with a Return Material Authorization (RMA) number, which we use to reference any information you have already provided and expedite the repair process. This number should be clearly marked on the outside of all returned package(s) and on any packing list(s) accompanying the shipment.

Contact Information

PCB Piezotronics, Inc.
3425 Walden Ave.
Depew, NY14043 USA
Toll-free: (800) 828-8840
24-hour SensorLine: (716) 684-0001
General inquiries: info@pcb.com
Repair inquiries: rma@pcb.com

For a complete list of distributors, global offices and sales representatives, visit our website, www.pcb.com.

Safety Considerations

This product is intended for use by qualified personnel who recognize shock hazards and are familiar with the precautions required to avoid injury. While our equipment is designed with user safety in mind, the protection provided by the equipment may be impaired if equipment is used in a manner not specified by this manual.

Discontinue use and contact our 24-Hour Sensorline if:

- Assistance is needed to safely operate equipment
- Damage is visible or suspected
- Equipment fails or malfunctions

For complete equipment ratings, refer to the enclosed specification sheet for your product.

Definition of Terms and Symbols

The following symbols may be used in this manual:



DANGER

Indicates an immediate hazardous situation, which, if not avoided, may result in death or serious injury.

**CAUTION**

Refers to hazards that could damage the instrument.

**NOTE**

Indicates tips, recommendations and important information. The notes simplify processes and contain additional information on particular operating steps.

The following symbols may be found on the equipment described in this manual:



This symbol on the unit indicates that high voltage may be present. Use standard safety precautions to avoid personal contact with this voltage.



This symbol on the unit indicates that the user should refer to the operating instructions located in the manual.



This symbol indicates safety, earth ground.



PCB工业监视和测量设备 - 中国RoHS2公布表

PCB Industrial Monitoring and Measuring Equipment - China RoHS 2 Disclosure Table

部件名称	有害物质					
	铅 (Pb)	汞 (Hg)	镉 (Cd)	六价铬 (Cr(VI))	多溴联苯 (PBB)	多溴二苯醚 (PBDE)
住房	0	0	0	0	0	0
PCB板	X	0	0	0	0	0
电气连接器	0	0	0	0	0	0
压电晶体	X	0	0	0	0	0
环氧	0	0	0	0	0	0
铁氟龙	0	0	0	0	0	0
电子	0	0	0	0	0	0
厚膜基板	0	0	X	0	0	0
电线	0	0	0	0	0	0
电缆	X	0	0	0	0	0
塑料	0	0	0	0	0	0
焊接	X	0	0	0	0	0
铜合金/黄铜	X	0	0	0	0	0
本表格依据 SJ/T 11364 的规定编制。						
0：表示该有害物质在该部件所有均质材料中的含量均在 GB/T 26572 规定的限量要求以下。						
X：表示该有害物质至少在该部件的某一均质材料中的含量超出 GB/T 26572 规定的限量要求。						
铅是欧洲RoHS指令2011/65/ EU附件三和附件四目前由于允许的豁免。						

CHINA RoHS COMPLIANCE

Component Name	Hazardous Substances					
	Lead (Pb)	Mercury (Hg)	Cadmium (Cd)	Chromium VI Compounds (Cr(VI))	Polybrominated Biphenyls (PBB)	Polybrominated Diphenyl Ethers (PBDE)
Housing	O	O	O	O	O	O
PCB Board	X	O	O	O	O	O
Electrical Connectors	O	O	O	O	O	O
Piezoelectric Crystals	X	O	O	O	O	O
Epoxy	O	O	O	O	O	O
Teflon	O	O	O	O	O	O
Electronics	O	O	O	O	O	O
Thick Film Substrate	O	O	X	O	O	O
Wires	O	O	O	O	O	O
Cables	X	O	O	O	O	O
Plastic	O	O	O	O	O	O
Solder	X	O	O	O	O	O
Copper Alloy/Brass	X	O	O	O	O	O

This table is prepared in accordance with the provisions of SJ/T 11364.

O: Indicates that said hazardous substance contained in all of the homogeneous materials for this part is below the limit requirement of GB/T 26572.

X: Indicates that said hazardous substance contained in at least one of the homogeneous materials for this part is above the limit requirement of GB/T 26572.

Lead is present due to allowed exemption in Annex III or Annex IV of the European RoHS Directive 2011/65/EU.

1.0 INTRODUCTION

ICP quartz strain sensors incorporate a built-in MOSFET microelectronic amplifier. This serves to convert the high impedance charge output into a low impedance voltage signal for analysis or recording. ICP quartz strain sensors, powered from a separate constant current source, operate over long ordinary coaxial or ribbon cable without signal degradation. The low impedance voltage signal is not affected by triboelectric cable noise or environmental contaminants.

Power to operate ICP sensors is generally in the form of a low cost, 24-27 VDC, 2-20 mA constant current supply. **Figure 1.1** schematically illustrates a typical ICP strain sensor system. PCB offers a number of AC or battery-powered, single or multi-channel power/signal conditioners, with or without gain capabilities for use with strain sensors. In addition, many data acquisition systems now incorporate constant current power for directly powering ICP sensors. Because static calibration or quasi-static short-term response lasting up to a few seconds is often required, PCB manufactures signal conditioners that provide DC coupling. **Figure 1.2** summarizes a complete 2-wire ICP system configuration.

ICP quartz strain sensors are well suited for continuous, unattended strain monitoring in harsh factory environments. Also, ICP sensor cost-per-channel is substantially lower, since they operate through standard, low-cost coaxial cable, and do not require expensive charge amplifiers.

Refer to the installation/outline drawing and specification sheet at the front of this manual for details and dimensions of the particular sensor model number(s) purchased. The following pages give a brief description of the sensor series, recommended mounting procedures, operation and recommended calibration.

In addition to standard products, PCB has the ability to design and manufacture custom sensors/systems for specific applications.

If questions arise regarding the operation or characteristics of the strain sensor products as outlined in this manual, feel free to contact an experienced applications engineer from the Force/Torque Division of PCB toll-free 888-684-0004.

2.0 DESCRIPTION

240 series quartz strain sensors are used to monitor the dynamic response of crimping, stamping, punching, forming and any other applications where it is crucial to maintain process control. These sensors are ideal in applications where mounting directly in the load path with a force sensor is not possible. Instead, the sensor can be mounted in an area that will provide the highest mechanical stress for the process to be monitored. Strain sensors are mounted to a structure by means of a supplied socket flat head screw, which threads into a corresponding tapped hole, and is then fastened securely as noted in the installation section of this manual. When used with a constant current signal conditioner, the sensor output voltage can be resolved in units of strain and then related to specific events that must be monitored in the process. After defining a signature voltage response for properly manufactured parts, the user can then determine an acceptable upper and lower control limit in order to maintain process control thereby preventing the acceptance of non-conforming products as finished goods.

Versions offering full-scale measurements of 10 $\mu\epsilon$ to 300 $\mu\epsilon$ are available. When powered by a constant current power supply and subjected to an input strain, an ICP strain sensor will provide a corresponding output voltage. A positive output voltage indicates that the structure being monitored is being subjected to a tensile force in the sensor mounting area and can also be resolved in units of strain. Likewise, a compressive force in this area will result in a negative output voltage. Refer to Sections 3.1, for recommended strain sensor mounting and torque requirements.

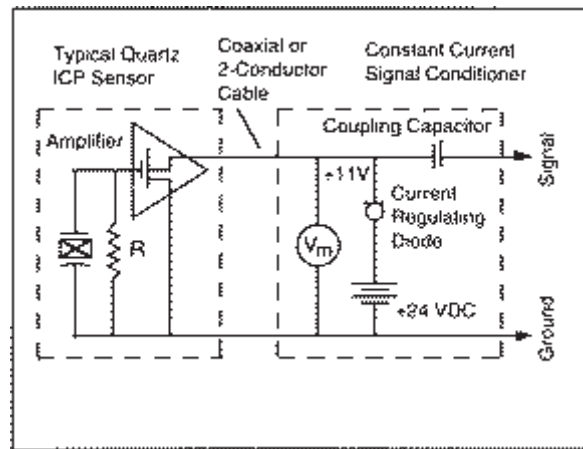

Figure 1.1 ICP® Sensor System Schematic

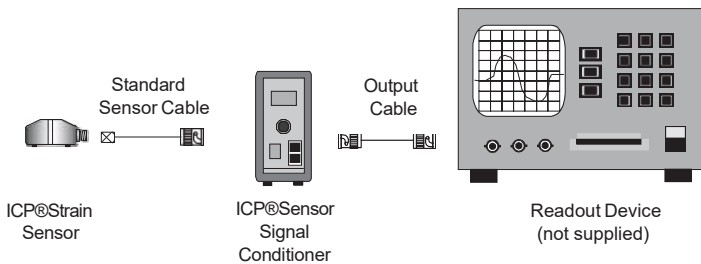

Figure 1.2 Typical ICP® Sensor System

In addition to ease of operation, ICP quartz strain sensors offer significant advantages over charge mode types. Because of the low impedance output and solid-state, hermetic construction,

3.0 INSTALLATION

CAUTION!

Please read all instructions before attempting to operate this product.

Damage to built-in amplifier due to incorrect power or misapplication is NOT covered by warranty

Refer to the Installation Drawing supplied with this manual for specific outline dimensions and installation details for your particular model. The specification is also included to provide details of the sensor's characteristic properties.

It is important that the mounting surface is clean and free of paint, oil, or other coatings that could prevent the proper transfer of strain into the mounting pads of the sensor. Poor surface contact may affect sensor sensitivity and result in erroneous data. Prior to mounting, it is recommended that the machine surface and the mounting pads of the sensor be cleaned with acetone. This will maintain proper coupling with these mating surfaces and prevent slippage at peak strain.

Connect one end of the coaxial cable to the sensor connector and the other end to the XDCR jack on the signal conditioner. Make sure to tighten the cable connector to the sensor. **DO NOT** spin the sensor onto the cable, as this fatigues the cable's center pin, resulting in a shorted signal and a damaged cable. If the cable cannot be attached prior to sensor installation, the protective cap should remain on the connector to prevent contamination or damage.

For installation in dirty, humid, or rugged environments, it is suggested that the connection be shielded against dust or moisture with shrink tubing or other protective material. Strain relieving the cable/sensor connection can also prolong cable life. **Mounting cables to a test structure with tape, clamps, or adhesives minimizes the chance of damage.**

3.1 STRAIN SENSOR INSTALLATION

The PCB 240 Series Strain Sensors are supplied with a M6 X 1-6G x 22 mm flat head screw for installation and preloading. Variability in machine screw finish necessitates the use of an assembly lubricant on the screw head and threads to ensure that 10 Nm of torque produces sufficient clamp load between the sensor and mounting surface. When assembly lubricant is not used sensor performance may degrade from specified values. Assembly lubricant is available from PCB, reference part number 080A82. Allow for the static component of the signal to discharge prior to calibration. Installations not preloaded to the recommended value, or that utilizes a screw of different material and/or dimensions than the supplied screw, may yield inaccurate

output readings. The supplied screw allows proper strain transmission to the sensor while holding the sensor in place. Properly machined holes for the mounting screw will ensure proper vertical orientation of the sensor. Refer to the installation drawing for additional mounting details.

Consult a PCB applications engineer for calibration and output recommendations.

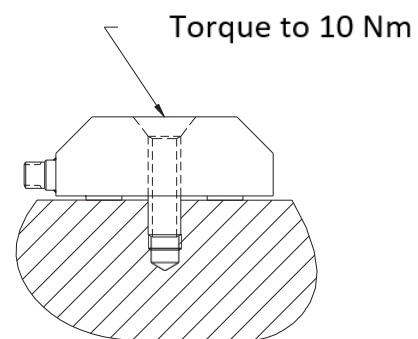
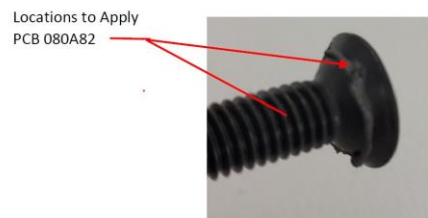

Figure 3.1 Strain Sensor Installation



4.0 OPERATION

4.1 TYPICAL ICP SYSTEM CONFIGURATION

Sensors with built-in ICP circuitry require a constant-current excitation voltage for operation. The enclosed Specification Sheet provides specific power requirements. Required supply voltage is normally 20 to 30 VDC, while the constant current required ranges from 2 to 20 mA.

PCB standard battery-powered signal conditioners are factory set at 2 mA and may be used to adequately drive a signal for 100 feet. PCB line signal supplies are factory set at 4 mA (and adjustable from 2 to 20 mA), enabling signals to be transmitted over hundreds of feet.

It is necessary to supply the sensor with a 2 to 20 mA constant current at +20 to +30 VDC through a current-regulating diode or equivalent circuit, contained in all PCB signal conditioners. See Guide G-0001B for powering and signal conditioning information pertaining to all ICP® instrumentation.

Most of the signal conditioners manufactured by PCB have an adjustable current feature allowing a choice of input currents from 2 to 20 mA. In general, for lowest noise (best resolution), choose the lower current ranges. When driving long cables (to several thousand feet), use the higher current, up to 20 mA maximum. Consult the factory to determine if higher current settings are required. Connect the sensor to the power unit as shown in the typical ICP® sensor systems below.

As displayed in **Figure 4.1**, operation requires the connection of the strain sensor first to a signal conditioner, then to a readout device (oscilloscope, meter, recorder, or A-to-D board) or to a readout device with built-in ICP sensor excitation. Tighten the coaxial cable to the sensor by hand to ensure good electrical contact.

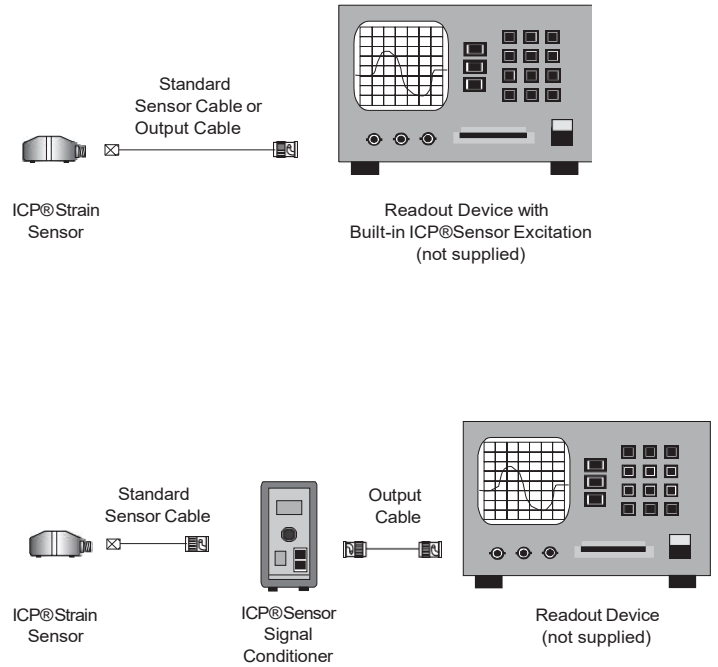

Figure 4.1 Typical ICP® System Configurations

5.0 POLARITY

Extension of the mounting area of an ICP strain sensor produces a positive-going voltage output. The retraction of the mounting area produces a negative-going voltage output.

6.0 LOW-FREQUENCY MONITORING

Strain sensors used for applications in short term, steady-state monitoring, such as sensor calibration, or short term, quasi-static testing should be powered by signal conditioners that operate in DC-coupled mode. PCB Series 484 Signal Conditioner operates in either AC or DC-coupled mode and may be supplied with gain features or a zero “clamped” output often necessary in repetitive, positive polarity pulse train applications.

If you wish to learn more about ICP sensors, consult PCB's General Signal Conditioning Guide, a brochure outlining the technical specifics associated with piezoelectric sensors. This brochure is available from PCB by request, free of charge.

7.0 DISCHARGE TIME CONSTANT

The discharge time constant (DTC) of the entire transduction system from sensor to readout must be considered when attempting to calibrate an ICP strain sensor by static methods. In order to take full advantage of the long DTC built into the strain sensor, it is best to DC couple from the sensor to the readout device. Several dual-mode PCB signal conditioners (e.g., Series 484) use direct coupling techniques to decouple the output signal from the sensor bias voltage. With the output of the signal conditioner coupled to a DC readout, such as a digital voltmeter (DVM) or oscilloscope, the time constant of the sensor is not compromised by AC coupling elsewhere in the system.

When DC coupling to a system, it is important to DC couple the entire system and not just from the sensor to the signal conditioner. The system time constant is determined by the shortest time constant in the system. For this reason, the signal conditioner, as well as the readout device, must be DC coupled.

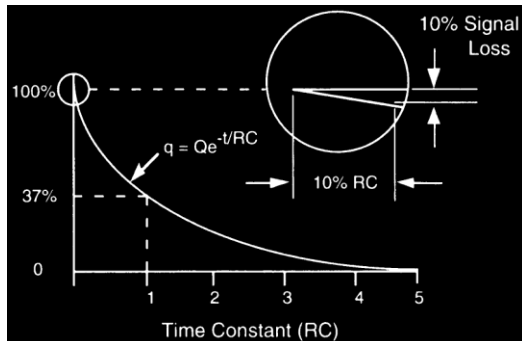

Figure 7.1 Characteristic Discharge Time Constant Curve

The discharge time constant represents the decay rate of an input signal. One DTC represents the amount of time taken for the signal to decay to 37% of the initial peak value. As illustrated in **Figure 7.1**, this is an exponential decay. Approximately five DTC intervals are needed for a peak signal to naturally decay back to zero.

The rule of thumb for signal discharge, as outlined in **Figure 7.2**, is this: for the first 10% of the DTC, the signal lost is approximately proportional to the time elapsed.

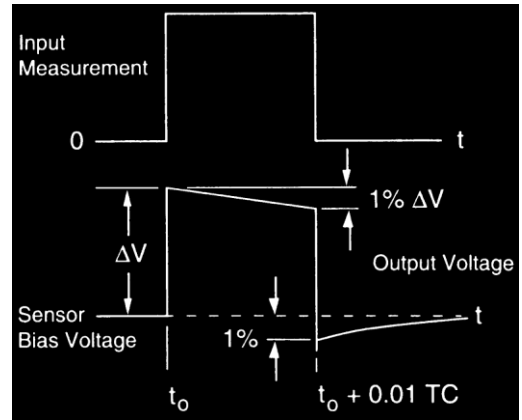

Figure 7.2 Step Function Response

For example, a sensor with a 150-second DTC loses approximately 1% of its output level the first 1.5 seconds (1% of 150) after the application of a steady state strain within the measuring range. In this case, the output reading must be taken within 1.5 seconds of the strain application for 1% accuracy.

If it is impossible to avoid AC coupling somewhere in the sensing system, try to keep the coupling DTC at least an order of magnitude longer than the DTC of the strain sensor. This avoids compromising the sensor DTC.

8.0 CALIBRATION

Strain sensors are calibrated relative to a strain gage reference sensor. A calibration certificate is supplied with each strain sensor providing its relative voltage sensitivity (mV/με). A calibration must be performed once strain sensors are installed in the specific equipment being measured. This is necessary so that a direct comparison of relative data can be made thereby allowing the user to set control limits and properly monitor a specific event as well as the entire process.

9.0 TROUBLESHOOTING

When a PCB signal conditioner with any of the following indicators are used, turn the power on and observe the voltmeter (or LED's) on the front panel. Typical indicators are marked as shown in the figure below.

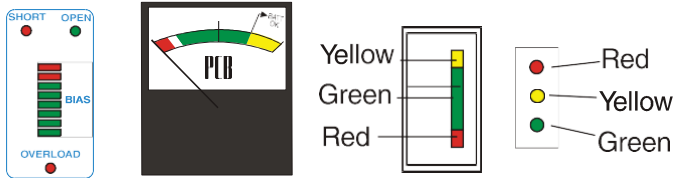

Normal Operation

INDICATOR	DVM READING	OPERATION
GREEN (Mid-Scale)	8 to 14 V	Proper range for most ICP sensors.
GREEN (Low End)	3 to 7 V	Proper range for low bias ICP sensors.
GREEN (High End)	15 to 17 V	Proper range for high bias ICP sensors.
RED	0 Volts	Short in the sensor, cable, or connections.
YELLOW	24 to 28 V	Open circuit in the sensor, cable, or connections. (Excitation voltage is being monitored.)

Output voltage moves from YELLOW to GREEN slowly until charging is complete. AC coupled signal conditioners require sufficient time to charge the internal coupling capacitor. Allow signal conditioner to charge for after 5 discharge time constants for stable operation.

Note: Most PCB strain sensors have an output bias of 8-14 VDC. Refer to the specification sheet in this manual for the bias range of the model you are using. If you are using a low bias sensor, the indicator will be at the bottom end of the green portion of the dial indicator, and may even be in the red portion. This is the expected range and indicates proper operation. Initial application of mounting torque will incur a negative-going output voltage. It is necessary to allow this output voltage to decay 5 DTC's prior to making measurements in order to prevent baseline shift where an absolute zero is needed throughout entire monitoring process.

10.0 MAINTENANCE

The sensor connector must be kept clean, especially if it is operating in a dusty and/or wet environment. If the cable is disconnected from the sensor, it is recommended to place the supplied black cap onto the connector to prevent contamination.

Observe the following precautions when using the sensor:

- A. Do not exceed the maximum strain levels for the strain sensor (see specification sheet).
- B. Do not subject the sensor to temperatures exceeding that of the specification, normally 250°F (121°C).
- C. Do not apply voltage to the sensor without current-limiting diodes or other current protection.
- D. Do not apply more than 20 mA of current to the strain sensor.
- E. When mounting the strain sensor, observe installation procedures detailed in Section 3.0 and as outlined on the specific sensor Installation Drawing to avoid over torquing when mounting.
- F. Do not apply more than 30 volts to the sensor.
- G. *Avoid metal-to-metal impacts* during applications, which can produce a high frequency ringing. Electrical low-pass filtering or a damping material can help reduce such effects.
- E. *Do not spin the sensor onto the cable.* This may fatigue the cable center pin, causing cable damage. Always insert the cable pin into the sensor and tighten the knurled cable nut to the sensor.

For additional information, refer to “Warranty, Service, Repair and Return Policies and Instructions.”

MANUAL NUMBER: 22676
MANUAL REVISION: B
ECN NUMBER: 54044

Performance	ENGLISH	SI	
Sensitivity(± 20 %)	100 mV/με	100 mV/με	
Measurement Range	50 pk με	50 pk με	[1]
Frequency Range(- 5 %)	0.015 Hz	0.015 Hz	[2]
Broadband Resolution(1 to 10,000 Hz)	0.0001 με	0.0001 με	[3]
Non-Linearity	≤ 2 %	≤ 2 %	[4]
Environmental			
Temperature Range(Operating)	-65 to +250 °F	-54 to +121 °C	[3]
Electrical			
Excitation Voltage	20 to 30 VDC	20 to 30 VDC	
Constant Current Excitation	2 to 20 mA	2 to 20 mA	
Output Bias Voltage	8 to 14 VDC	8 to 14 VDC	
Discharge Time Constant	≥ 35 sec	≥ 35 sec	
Physical			
Sensing Element	Quartz	Quartz	
Housing Material	Stainless Steel	Stainless Steel	
Electrical Connector	10-32 Coaxial Jack	10-32 Coaxial Jack	
Electrical Connection Position	Side	Side	
Sealing	Epoxy	Epoxy	
Mounting Torque	7.38 ft-lb	10 Nm	
Size (Width x Length x Height)	0.67 in x 1.81 in x 0.6 in	17 mm x 46 mm x 15.2 mm	
Weight	1.6 oz	45 gm	[3]

OPTIONAL VERSIONS

Optional versions have identical specifications and accessories as listed for the standard model except where noted below. More than one option may be used.

W - Water Resistant Cable

NOTES:

[1]Based on 100 mV/με sensitivity.
 [2]Calculated from discharge time constant.
 [3]Typical.
 [4]Zero-based, least-squares, straight line method.
 [5]See PCB Declaration of Conformance PS023 for details.

SUPPLIED ACCESSORIES:

Model 080A82 Assembly Lubricant
 Model M081A100 M6 x 1.00 flathead screw (1)

Entered: ND	Engineer: RPF	Sales: BS	Approved: RPF	Spec Number:
Date: 07/31/2023	Date: 07/31/2023	Date: 07/31/2023	Date: 07/31/2023	36895

PCB PIEZOTRONICS
AN AMPHENOL COMPANY

Phone: 716-684-0001
 Fax: 716-684-0987
 E-Mail: info@pcb.com

3425 Walden Avenue, Depew, NY 14043



All specifications are at room temperature unless otherwise specified.
 In the interest of constant product improvement, we reserve the right to change specifications without notice.
 ICP® is a registered trademark of PCB Piezotronics, Inc.

PCB Piezotronics Inc. claims proprietary rights in the information disclosed hereon. Neither it nor any reproduction thereof will be disclosed to others without the written consent of PCB Piezotronics Inc.

REVISIONS

REV	DESCRIPTION	DIN
F	ADDED NOTE #4	54044

22493

ELECTRICAL CONNECTOR
10-32 UNF - 2A

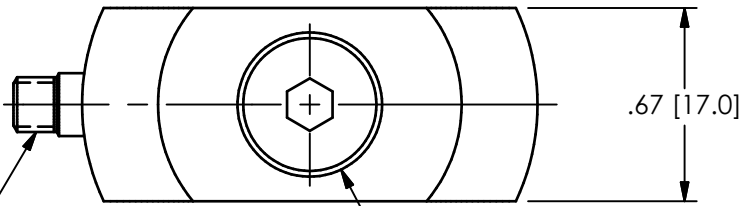

MODEL M081A100:
M6x1 - 6g X .87 [22.0] LONG
FLAT HEAD HEX SCREW

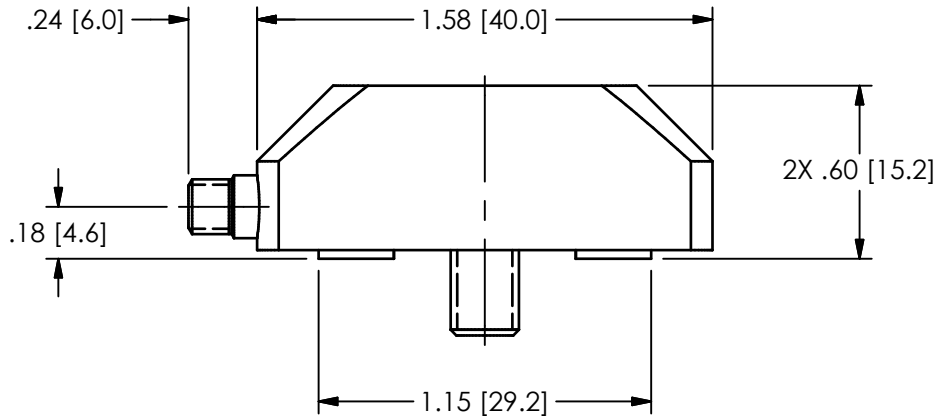

MOUNTING HOLE PREPARATION:

Ø.199 [5.05] ∇ .45 [11.4] ∇ 1
M6x1 - 6H ∇ .35 [8.9]

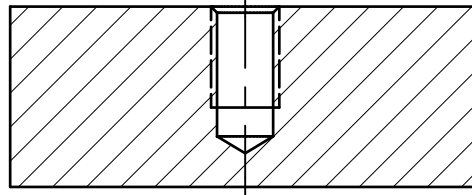

- ∇ 4 APPLY LUBRICANT (080A82 OR EQUIVALENT) TO THE THREADS AND THE HEAD OF THE MOUNTING BOLT
- ∇ 3 TORQUE SCREW TO 86 IN-LBS [10 Nm] MINIMUM
- ∇ 2 MOUNTING SURFACE MUST BE FLAT TO WITHIN .001 [.03] WITH AT LEAST A SURFACE FINISH OF 125 [3.2]
- ∇ 1 DRILL PERPENDICULAR TO MOUNTING SURFACE WITHIN 1°

UNLESS OTHERWISE SPECIFIED TOLERANCES ARE:

DRAWN CHECKED ENGINEER

DIMENSIONS IN INCHES	DIMENSIONS IN MILLIMETERS [IN BRACKETS]
DECIMALS XX ±.01 XXX ±.005	DECIMALS X ± 0.3 XX ± 0.13
ANGLES ± 2 DEGREES	ANGLES ± 2 DEGREES

NJF	07/27/23	JDM	07/27/23	RF	07/27/23
-----	----------	-----	----------	----	----------

PCB PIEZOTRONICS
AN AMPHENOL COMPANY

3425 WALDEN AVE. DEPEW, NY 14043
(716) 684-0001 E-MAIL: sales@pcb.com

CABLE TOLERANCES IN ENGLISH	CABLE TOLERANCES IN METRIC
1' ≤ LENGTH < 1' = +1"/ - 0	2.54cm ≤ LENGTH < 30.5cm = +2.54cm/ - 0
1' ≤ LENGTH < 5' = +2"/ - 0	30.5cm ≤ LENGTH < 1.5m = +5.1cm/ - 0
5' ≤ LENGTH < 100' = +6"/ - 0	1.5m ≤ LENGTH < 30.5m = +15.2cm/ - 0
100' ≤ LENGTH = +1"/ - 0	30.5m ≤ LENGTH = +30.5cm/ - 0

TITLE
INSTALLATION DRAWING
MODEL 240XXX SERIES
STRAIN SENSOR

CODE IDENT. NO.	DWG. NO.
52681	22493

FILLETS AND RADII	FILLETS AND RADII
.003 - .005	0.07 - 0.13

SCALE: 1.5X	SHEET 1 OF 1
-------------	--------------