



Model 132A31/004AW

Micro ICP® pressure sensor, 140 mV/psi, pigtail conn. (for high frequency

Installation and Operating Manual

**For assistance with the operation of this product,
contact PCB Piezotronics, Inc.**

**Toll-free: 800-828-8840
24-hour SensorLine: 716-684-0001
Fax: 716-684-0987
E-mail: info@pcb.com
Web: www.pcb.com**





Warranty, Service, Repair, and Return Policies and Instructions
--

The information contained in this document supersedes all similar information that may be found elsewhere in this manual.

Total Customer Satisfaction – PCB Piezotronics guarantees Total Customer Satisfaction. If, at any time, for any reason, you are not completely satisfied with any PCB product, PCB will repair, replace, or exchange it at no charge. You may also choose to have your purchase price refunded in lieu of the repair, replacement, or exchange of the product.

Service – Due to the sophisticated nature of the sensors and associated instrumentation provided by PCB Piezotronics, user servicing or repair is not recommended and, if attempted, may void the factory warranty. Routine maintenance, such as the cleaning of electrical connectors, housings, and mounting surfaces with solutions and techniques that will not harm the physical material of construction, is acceptable. Caution should be observed to insure that liquids are not permitted to migrate into devices that are not hermetically sealed. Such devices should only be wiped with a dampened cloth and never submerged or have liquids poured upon them.

Repair – In the event that equipment becomes damaged or ceases to operate, arrangements should be made to return the equipment to PCB Piezotronics for repair. User servicing or repair is not recommended and, if attempted, may void the factory warranty.

Calibration – Routine calibration of sensors and associated instrumentation is recommended as this helps build confidence in measurement accuracy and acquired data. Equipment calibration cycles are typically established by the users own quality regimen. When in doubt about a calibration cycle, a good “rule of thumb” is to recalibrate on an annual basis. It is also good practice to recalibrate after exposure to any severe temperature extreme, shock, load, or other environmental influence, or prior to any critical test.

PCB Piezotronics maintains an ISO-9001 certified metrology laboratory and offers calibration services, which are accredited by A2LA to ISO/IEC 17025, with full traceability to SI through N.I.S.T. In addition to the normally supplied calibration, special testing is also available, such as: sensitivity at elevated or cryogenic temperatures, phase response, extended high or low frequency response, extended range, leak testing, hydrostatic pressure testing, and others. For information on standard recalibration services or special testing, contact your local PCB Piezotronics distributor, sales representative, or factory customer service representative.

Returning Equipment – *Following these procedures will insure that your returned materials are handled in the most expedient manner.* Before

returning any equipment to PCB Piezotronics, contact your local distributor, sales representative, or factory customer service representative to obtain a Return **Warranty, Service, Repair, and Return Policies and Instructions** Materials Authorization (RMA) Number. This RMA number should be clearly marked on the outside of all package(s) and on the packing list(s) accompanying the shipment. A detailed account of the nature of the problem(s) being experienced with the equipment should also be included inside the package(s) containing any returned materials.

A Purchase Order, included with the returned materials, will expedite the turn-around of serviced equipment. It is recommended to include authorization on the Purchase Order for PCB to proceed with any repairs, as long as they do not exceed 50% of the replacement cost of the returned item(s). PCB will provide a price quotation or replacement recommendation for any item whose repair costs would exceed 50% of replacement cost, or any item that is not economically feasible to repair. For routine calibration services, the Purchase Order should include authorization to proceed and return at current pricing, which can be obtained from a factory customer service representative.

Warranty – All equipment and repair services provided by PCB Piezotronics, Inc. are covered by a limited warranty against defective material and workmanship for a period of one year from date of original purchase. Contact

PCB for a complete statement of our warranty. Expendable items, such as batteries and mounting hardware, are not covered by warranty. Mechanical damage to equipment due to improper use is not covered by warranty. Electronic circuitry failure caused by the introduction of unregulated or improper excitation power or electrostatic discharge is not covered by warranty.

Contact Information – International customers should direct all inquiries to their local distributor or sales office. A complete list of distributors and offices can be found at www.pcb.com. Customers within the United States may contact their local sales representative or a factory customer service representative. A complete list of sales representatives can be found at www.pcb.com. Toll-free telephone numbers for a factory customer service representative, in the division responsible for this product, can be found on the title page at the front of this manual. Our ship to address and general contact numbers are:

PCB Piezotronics, Inc.
3425 Walden Ave.
Depew, NY14043 USA
Toll-free: (800) 828-8840
24-hour SensorLineSM: (716) 684-0001
Website: www.pcb.com
E-mail: info@pcb.com



PCB工业监视和测量设备 - 中国RoHS2公布表
 PCB Industrial Monitoring and Measuring Equipment - China RoHS 2 Disclosure Table

部件名称	有害物质					
	铅 (Pb)	汞 (Hg)	镉 (Cd)	六价铬 (Cr(VI))	多溴联苯 (PBB)	多溴二苯醚 (PBDE)
住房	○	○	○	○	○	○
PCB板	X	○	○	○	○	○
电气连接器	○	○	○	○	○	○
压电晶体	X	○	○	○	○	○
环氧	○	○	○	○	○	○
铁氟龙	○	○	○	○	○	○
电子	○	○	○	○	○	○
厚膜基板	○	○	X	○	○	○
电线	○	○	○	○	○	○
电缆	X	○	○	○	○	○
塑料	○	○	○	○	○	○
焊接	X	○	○	○	○	○
铜合金/黄铜	X	○	○	○	○	○
本表格依据 SJ/T 11364 的规定编制。						
○：表示该有害物质在该部件所有均质材料中的含量均在 GB/T 26572 规定的限量要求以下。						
X：表示该有害物质至少在该部件的某一均质材料中的含量超出 GB/T 26572 规定的限量要求。						
铅是欧洲RoHS指令2011/65/ EU附件三和附件四目前由于允许的豁免。						

CHINA RoHS COMPLIANCE

Component Name	Hazardous Substances					
	Lead (Pb)	Mercury (Hg)	Cadmium (Cd)	Chromium VI Compounds (Cr(VI))	Polybrominated Biphenyls (PBB)	Polybrominated Diphenyl Ethers (PBDE)
Housing	O	O	O	O	O	O
PCB Board	X	O	O	O	O	O
Electrical Connectors	O	O	O	O	O	O
Piezoelectric Crystals	X	O	O	O	O	O
Epoxy	O	O	O	O	O	O
Teflon	O	O	O	O	O	O
Electronics	O	O	O	O	O	O
Thick Film Substrate	O	O	X	O	O	O
Wires	O	O	O	O	O	O
Cables	X	O	O	O	O	O
Plastic	O	O	O	O	O	O
Solder	X	O	O	O	O	O
Copper Alloy/Brass	X	O	O	O	O	O

This table is prepared in accordance with the provisions of SJ/T 11364.

O: Indicates that said hazardous substance contained in all of the homogeneous materials for this part is below the limit requirement of GB/T 26572.

X: Indicates that said hazardous substance contained in at least one of the homogeneous materials for this part is above the limit requirement of GB/T 26572.

Lead is present due to allowed exemption in Annex III or Annex IV of the European RoHS Directive 2011/65/EU.

DOCUMENT NUMBER: 21354

DOCUMENT REVISION: C

ECN: 45605

1.0 INTRODUCTION

132 Series Microsensors are small, piezoelectric pressure sensors featuring extremely fast response for measurement of short wavelength pressure pulses. The short time constant of some models filters off the longer duration portion of pressure pulses, allowing differentiation of consecutive pressure pulses.

132 Series Microsensors contain integrated ICP[®] circuit amplifiers which operate as source followers and provide very high-frequency response. These micro-integrated circuit amplifiers convert the high-impedance voltage from the crystals into low-impedance voltage of less than 100 ohms.

Output from the microsensors may be coupled directly into oscilloscopes, recorders and A to D converters. Power to operate the IC amplifier and the output signal are conducted over a single conductor, two-wire cable with the ground serving as signal return. Special low-noise cables are not required. The calibrated mV/psi output of these microsensors is not attenuated nor is noise appreciably increased by the cable.

2.0 DESCRIPTION

132 Series Microsensors feature small diameter pressure-sensing surfaces incorporating very small (< 1 mm) piezoelectric sensing elements. The small size of the sensing elements imparts extremely fast response time to the microsensors.

The charge generated by deflection of the piezoelectric element when subjected to shock pressures creates a voltage on the input capacitance at the gate of the microsensor ICP[®] amplifier. The amplifier, in conjunction with the source element, transforms the input into a low-impedance output signal of equal amplitude. The DC bias that exists on the signal lead is removed from the output signal by a coupling capacitor in the power supply. Resistors in the internal ICP[®] amplifiers of the microsensors set the internal discharge time constant, which

determines the low-frequency response of the microsensors. (Refer to General Guide to ICP[®] Instrumentation, G-0001, for complete details.)

Below are the available configurations for the 132 Series Microsensors.

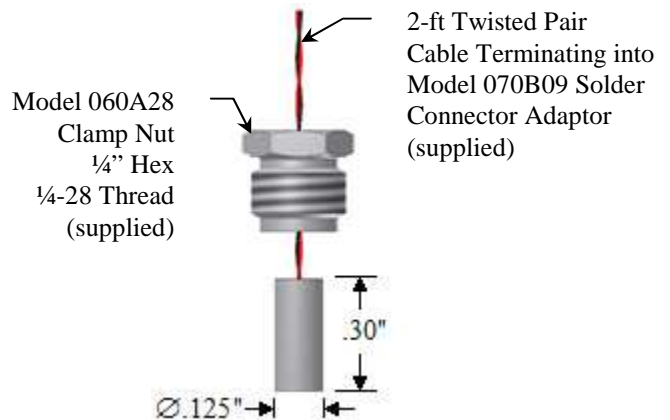

**Model 132A31 Time-of-Arrival
ICP[®] Microsensor**

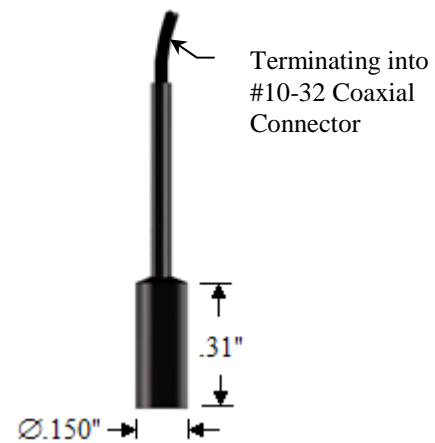

Model 132A32

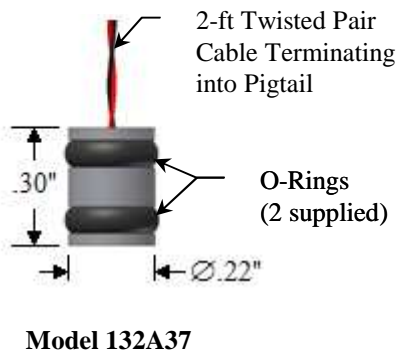
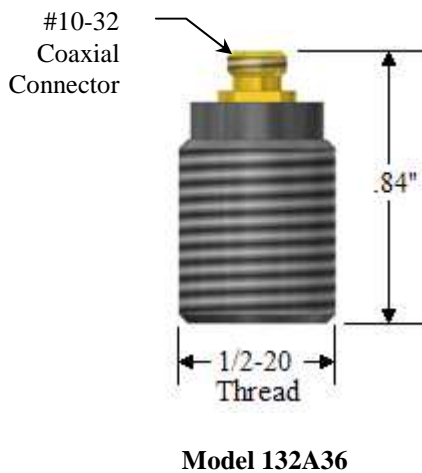
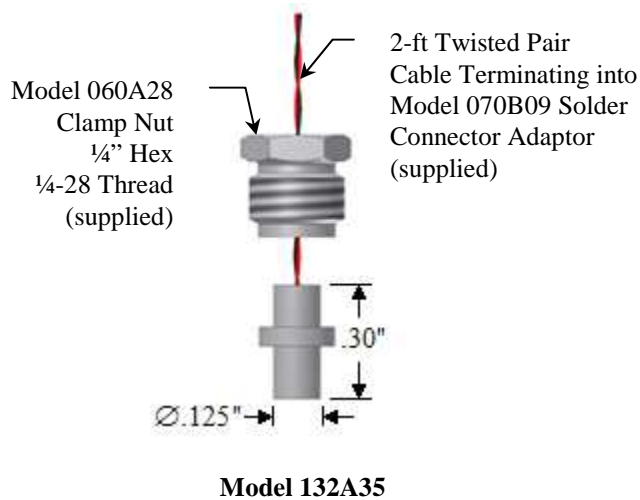

3.0 INSTALLATION

Refer to the installation drawing for details. If the microsensors are to be subjected to pressures beyond their specified range, be sure to use backing nuts to prevent the sensors from backing out of their mounting ports. (Thread adaptors are available from PCB to facilitate mounting.)

Connect the microsensors to an ICP® power supply. Use standard two-conductor cable between the sensor and the ICP® power unit.

Next, connect the power unit to a readout device, e.g., oscilloscope, recorder or high-speed A to D converter.

4.0 OPERATION

Switch the ICP® power unit on and observe reading of bias-monitoring voltmeter on front panel of power unit.

If indicator is in green section of indicator panel, the IC amplifier is providing proper bias (normally +11 VDC), cable connections are normal and the system is ready to operate.

If the needle moves to the red area of the fault monitor meter, output is zero and a short is indicated. The short could be located in the amplifier cable connectors or in the power unit.

If the pointer moves into the yellow area of the fault monitor meter, an open circuit is indicated with full power supply voltage. An open circuit could be the result of a faulty amplifier, an open cable or open connectors.

Allow the sensor to thermally stabilize for about one minute. A signal drift may occur when the output cable is connected to the readout instrument.

The drift occurs during charging of the coupling capacitor in the power unit. The signal will stabilize in several minutes.

4.1 OPERATION BEYOND RANGE SPECIFICATION

Because 132 Series Microsensors can be installed using RTV-like potting materials to hold them in place, maximum pressure specifications are given to prevent the sensors from being extruded from the mounting holes. Static or slow dynamic overpressures are more apt to cause a problem than a short dynamic shock pulse. Use of backing nuts will minimize the possibility of a problem.

The microsensors are capable of responding to dynamic overpressures up to ten times the specified range. The output will be “clipped” (look flat-topped on the readout) after about 10 volts.

The initial rise of the output will be accurate up to the point of clipping. This can allow for an accurate time-of-arrival measurement, even though the peak pressure cannot be measured.

5.0 CALIBRATION

A shock tube is used to calibrate the microsensors.

6.0 MAINTENANCE AND REPAIR

Except for repair of wires, the microsensors are not field-repairable. In case of serious malfunction, contact the PCB at (888) 684-0011.

It is well to observe the following precautions in using the microsensors:

1. Do not exceed specified pressure levels without proper mounting.
2. Do not subject microsensors to temperatures exceeding 174 °F (79 °C).
3. Do not apply voltage to sensors without current-limiting diodes or other current protection. (PCB ICP[®] power supplies feature proper voltage and current protection.)
4. Do not apply more than 20 mA of current to the microsensors.

Model Number 132A31	ICP® PRESSURE SENSOR	Revision: R ECN #: 44634
------------------------	-----------------------------	-----------------------------

	ENGLISH	SI	
Performance			
Measurement Range	50 psi	345 kPa	
Sensitivity(± 30 %)	140 mV/psi	20.3 mV/kPa	
Maximum Pressure(Dynamic)	800 psi	5516 kPa	
Resolution	0.001 psi	0.007 kPa	
Resonant Frequency	≥ 1000 kHz	≥ 1000 kHz	
Rise Time(Incident)	≤ 3 μ sec	≤ 3 μ sec	[1]
Rise Time(Reflected)	≤ 0.5 μ sec	≤ 0.5 μ sec	[2]
Low Frequency Response(-5 %)	11,000 Hz	11,000 Hz	
Environmental			
Temperature Range(Operating)	0 to +175 °F	-18 to +79 °C	
Electrical			
Output Polarity(Positive Pressure)	Positive	Positive	
Discharge Time Constant(at room temp)	≥ .000045 sec	≥ .000045 sec	
Excitation Voltage	20 to 30 VDC	20 to 30 VDC	
Constant Current Excitation	2 to 20 mA	2 to 20 mA	
Output Impedance	≤ 100 Ohm	≤ 100 Ohm	
Output Bias Voltage	8 to 14 VDC	8 to 14 VDC	
Physical			
Sensing Element	Ceramic	Ceramic	
Housing Material	Stainless Steel	Stainless Steel	
Sealing	Epoxy	Epoxy	
Electrical Connector	Integral Twisted Pair	Integral Twisted Pair	
Weight(without clamp nut)	0.018 oz	0.52 gm	[3]

OPTIONAL VERSIONS

Optional versions have identical specifications and accessories as listed for the standard model except where noted below. More than one option may be used.

M - Metric Mount

N - Negative Output Polarity

W - Water Resistant Cable

NOTES:

[1]Rise time in air at Mach 1
 [2]Rise time at 20mA
 [3]Weight including cable.

SUPPLIED ACCESSORIES:

Model 060A28 Clamp Nut, 1/4-28 x 1/4" Hex (1)
 Model 070B09 Solder adaptor (1)

Entered: JM	Engineer: MJK	Sales: RWM	Approved: APB	Spec Number:
Date: 10/6/2015	Date: 10/6/2015	Date: 10/6/2015	Date: 10/6/2015	132-1310-80

*All specifications are at room temperature unless otherwise specified.
 In the interest of constant product improvement, we reserve the right to change specifications without notice.
 ICP® is a registered trademark of PCB Group, Inc.*



Phone: 716-684-0001
 Fax: 716-684-0987
 E-Mail: info@pcb.com

3425 Walden Avenue, Depew, NY 14043

PCB Piezotronics Inc. claims proprietary rights in the information disclosed hereon. Neither it nor any reproduction thereof will be disclosed to others without the written consent of PCB Piezotronics Inc.

REVISIONS		
REV	DESCRIPTION	DIN
D	ADDED WIRE NOTE	44937

6574

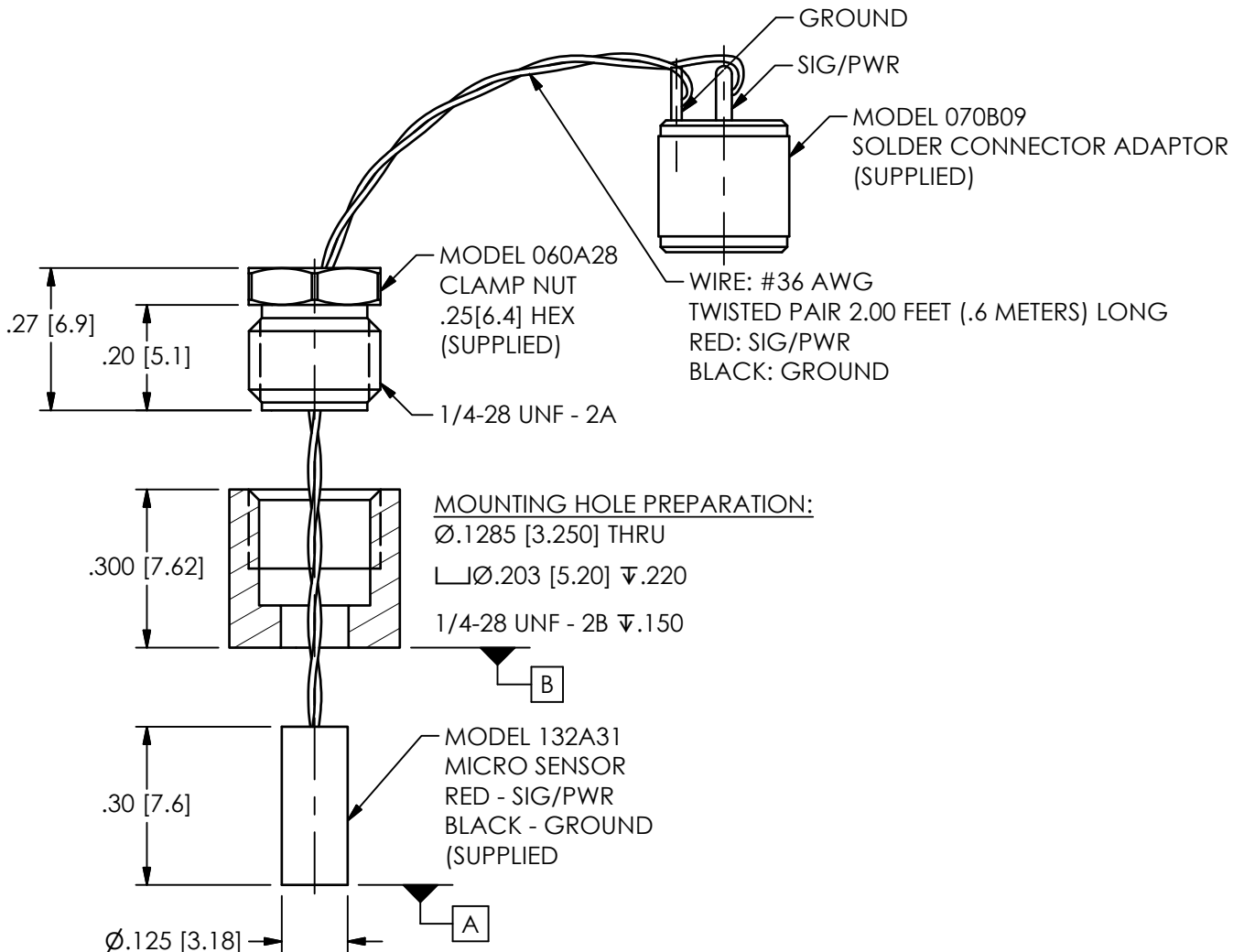

- 6.) ALLOW RTV TO FULLY CURE
- 5.) REMOVE EXCESSIVE RTV FROM MICRO SENSOR AND MOUNTING HOLE SURFACES
- 4.) WHILE APPLYING FINGER PRESSURE TO THE BOTTOM OF THE MICRO SENSOR, UNTIGHTEN CLAMP NUT UNTIL DATUM A AND B ARE FLUSH WITH EACH OTHER
- 3.) INSERT MICRO SENSOR INTO BOTTOM OF MOUNTING HOLE
- 2.) HAND TIGHTEN CLAMP NUT INTO MOUNTING HOLE
- 1.) LIGHTLY COAT THE INSIDE DIAMETER OF MOUNTING HOLE, OUTSIDE DIAMETER OF MICRO SENSOR (MODEL 132A31), AND CLAMP NUT (MODEL 060A28) WITH RTV

UNLESS OTHERWISE SPECIFIED TOLERANCES ARE:		DRAWN		CHECKED		ENGINEER		<p>3425 WALDEN AVE. DEPEW, NY 14043 (716) 684-0001 E-MAIL: sales@pcb.com</p>	
DIMENSIONS IN INCHES	DIMENSIONS IN MILLIMETERS [IN BRACKETS]	BB	1/13/16	ECB	1/13/16	MJK	1/13/16		
DECIMALS XX ±.01 XXX ±.005	DECIMALS X ±0.3 XX ±0.13	TITLE INSTALLATION DRAWING MODEL 132A31 MICRO SENSOR							CODE IDENT. NO. 52681
ANGLES ± 2 DEGREES	ANGLES ± 2 DEGREES								DWG. NO. 6574
FILLETS AND RADII .003 - .005	FILLETS AND RADII 0.07 - 0.13	SCALE: 3X		SHEET 1 OF 1					