



Model 103B01

Acoustic ICP® pressure sensor, 3 psi, 1500 mV/psi, integral 2-wire cable, accel. comp.

Installation and Operating Manual

**For assistance with the operation of this product,
contact the PCB Piezotronics, Inc.**

Toll-free: 716-684-0001

24-hour SensorLine: 716-684-0001

Fax: 716-684-0987

E-mail: info@pcb.com

Web: www.pcb.com



Repair and Maintenance

PCB guarantees Total Customer Satisfaction through its “Lifetime Warranty Plus” on all Platinum Stock Products sold by PCB and through its limited warranties on all other PCB Stock, Standard and Special products. Due to the sophisticated nature of our sensors and associated instrumentation, **field servicing and repair is not recommended and, if attempted, will void the factory warranty.**

Beyond routine calibration and battery replacements where applicable, our products require no user maintenance. Clean electrical connectors, housings, and mounting surfaces with solutions and techniques that will not harm the material of construction. Observe caution when using liquids near devices that are not hermetically sealed. Such devices should only be wiped with a dampened cloth—never saturated or submerged.

In the event that equipment becomes damaged or ceases to operate, our Application Engineers are here to support your troubleshooting efforts 24 hours a day, 7 days a week. Call or email with model and serial number as well as a brief description of the problem.

Calibration

Routine calibration of sensors and associated instrumentation is necessary to maintain measurement accuracy. We recommend calibrating on an annual basis, after exposure to any extreme environmental influence, or prior to any critical test.

PCB Piezotronics is an ISO-9001 certified company whose calibration services are accredited by A2LA to ISO/IEC 17025, with full traceability to SI through N.I.S.T. In addition to our standard calibration services, we also offer specialized tests, including: sensitivity at elevated or cryogenic temperatures, phase response, extended high or low frequency response, extended range, leak testing, hydrostatic pressure testing, and others. For more information, contact your local PCB Piezotronics distributor, sales representative, or factory customer service representative.

Returning Equipment

If factory repair is required, our representatives will provide you with a Return Material Authorization (RMA) number, which we use to reference any information you have already provided and expedite the repair process. This number should be clearly marked on the outside of all returned package(s) and on any packing list(s) accompanying the shipment.

Contact Information

PCB Piezotronics, Inc.
3425 Walden Ave.
Depew, NY14043 USA
Toll-free: (800) 828-8840
24-hour SensorLine: (716) 684-0001
General inquiries: info@pcb.com
Repair inquiries: rma@pcb.com

For a complete list of distributors, global offices and sales representatives, visit our website, www.pcb.com.

Safety Considerations

This product is intended for use by qualified personnel who recognize shock hazards and are familiar with the precautions required to avoid injury. While our equipment is designed with user safety in mind, the protection provided by the equipment may be impaired if equipment is used in a manner not specified by this manual.

Discontinue use and contact our 24-Hour Sensorline if:

- Assistance is needed to safely operate equipment
- Damage is visible or suspected
- Equipment fails or malfunctions

For complete equipment ratings, refer to the enclosed specification sheet for your product.

Definition of Terms and Symbols

The following symbols may be used in this manual:



DANGER

Indicates an immediate hazardous situation, which, if not avoided, may result in death or serious injury.

**CAUTION**

Refers to hazards that could damage the instrument.

**NOTE**

Indicates tips, recommendations and important information. The notes simplify processes and contain additional information on particular operating steps.

The following symbols may be found on the equipment described in this manual:



This symbol on the unit indicates that high voltage may be present. Use standard safety precautions to avoid personal contact with this voltage.



This symbol on the unit indicates that the user should refer to the operating instructions located in the manual.



This symbol indicates safety, earth ground.



PCB工业监视和测量设备 - 中国RoHS2公布表

PCB Industrial Monitoring and Measuring Equipment - China RoHS 2 Disclosure Table

部件名称	有害物质					
	铅 (Pb)	汞 (Hg)	镉 (Cd)	六价铬 (Cr(VI))	多溴联苯 (PBB)	多溴二苯醚 (PBDE)
住房	0	0	0	0	0	0
PCB板	X	0	0	0	0	0
电气连接器	0	0	0	0	0	0
压电晶体	X	0	0	0	0	0
环氧	0	0	0	0	0	0
铁氟龙	0	0	0	0	0	0
电子	0	0	0	0	0	0
厚膜基板	0	0	X	0	0	0
电线	0	0	0	0	0	0
电缆	X	0	0	0	0	0
塑料	0	0	0	0	0	0
焊接	X	0	0	0	0	0
铜合金/黄铜	X	0	0	0	0	0
本表格依据 SJ/T 11364 的规定编制。						
0：表示该有害物质在该部件所有均质材料中的含量均在 GB/T 26572 规定的限量要求以下。						
X：表示该有害物质至少在该部件的某一均质材料中的含量超出 GB/T 26572 规定的限量要求。						
铅是欧洲RoHS指令2011/65/ EU附件三和附件四目前由于允许的豁免。						

CHINA RoHS COMPLIANCE

Component Name	Hazardous Substances					
	Lead (Pb)	Mercury (Hg)	Cadmium (Cd)	Chromium VI Compounds (Cr(VI))	Polybrominated Biphenyls (PBB)	Polybrominated Diphenyl Ethers (PBDE)
Housing	O	O	O	O	O	O
PCB Board	X	O	O	O	O	O
Electrical Connectors	O	O	O	O	O	O
Piezoelectric Crystals	X	O	O	O	O	O
Epoxy	O	O	O	O	O	O
Teflon	O	O	O	O	O	O
Electronics	O	O	O	O	O	O
Thick Film Substrate	O	O	X	O	O	O
Wires	O	O	O	O	O	O
Cables	X	O	O	O	O	O
Plastic	O	O	O	O	O	O
Solder	X	O	O	O	O	O
Copper Alloy/Brass	X	O	O	O	O	O

This table is prepared in accordance with the provisions of SJ/T 11364.

O: Indicates that said hazardous substance contained in all of the homogeneous materials for this part is below the limit requirement of GB/T 26572.

X: Indicates that said hazardous substance contained in at least one of the homogeneous materials for this part is above the limit requirement of GB/T 26572.

Lead is present due to allowed exemption in Annex III or Annex IV of the European RoHS Directive 2011/65/EU.

OPERATION MANUAL FOR
MICROPHONE
Series 103A

1.0 DESCRIPTION

The Series 103A microphones are high-sensitivity pressure sensors featuring miniature size, built-in solid state electronics and acceleration compensation.

The Model 103A (see installation drawing) has pigtail leads extending radially from the side of the unit and has a nominal sensitivity of 1500 mV/psi.

The Model 103A11 is similar in appearance and in mode of electrical connection, but differs from the Model 103A in that the sensitivity is nominally 500 mV/psi.

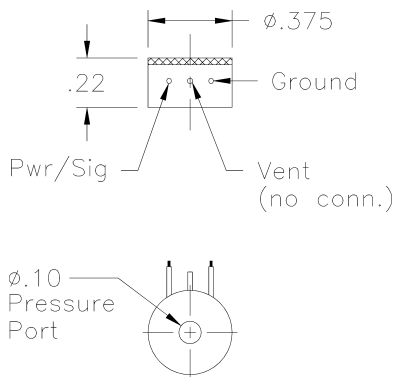

Models 103A and 103A11: ICP® Sound Pressure Sensors

The Model 103A02 is similar physically to the 103A and has similar sensitivity (1500 mV/psi), but the electrical connection is made through a top mounted 10-32 coaxial connector.

The Model 103A12 also has the top connector like the 103A02 but the sensitivity is 500 mV/psi.

These units are ideal for wind tunnel testing of models because of the small size and high sensitivity.

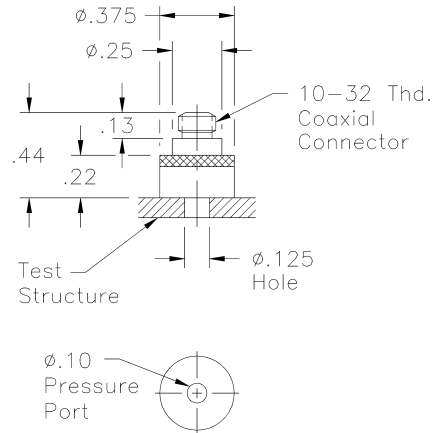

Models 103A02 and 103A12: ICP® Sound Pressure Sensors

2.0 DESCRIPTION

(Refer to installation drawing no. 103-1010-90 included as part of this manual.)

The 103A Series Sensors utilize a bimorph bender crystal cantilevered from the side wall and attached to the center of a thin recessed invar diaphragm. Pressure acting on the surface of the diaphragm results in a net force which strains (or deflects) the diaphragm in proportion to the applied pressure. The diaphragm bends the crystal creating an output voltage which is also proportional to applied pressure.

This voltage is fed to the gate of a miniature MOSFET source follower amplifier which reduces the output impedance to less than 100 Ohms allowing the driving of long cables and permitting operating directly into most readout instruments.

Refer to Bulletin G-0001B, "General Guide to ICP® Instrumentation" for a detailed description of the built-in amplifier concept.

Models 103A, A02, A11, and A12 have output signals superimposed upon a +4 V (approx.) bias level at the amplifier output. All PCB signal conditioners are designed to eliminate this bias voltage while supplying power to the internal amplifier.

OPERATION MANUAL FOR MICROPHONE Series 103A

The result is a two-wire system, precluding the need for multi-conductor cabling.

A second diaphragm, located behind the pressure diaphragm and attached to another bimorph bender crystal acting in opposition to the pressure crystal, provides acceleration compensation to the Series 103A Sensors.

3.0 INSTALLATION

As shown in installation drawing 103-1010-90, the Series 103A Microphones may be properly mounted in several ways, the exact method chosen being a function of the space available along with other use dictated parameters.

The simplest method of mounting, and also the one that utilizes the least volume, is the adhesive method. The microphone is simply bonded directly to the mounting surface with an (at least) .10" diameter hole through the surface to feed the pressure signal to the diaphragm.

Many different types of adhesives may be used to bond the 103A in this manner. The important point being to apply the adhesive very sparingly so that removal does not damage the sensor.

The 103A may also be mounted using the Model 061A04 Servo clamps if space is available.

The Model 060A11 Clamp Nut may only be used with the top connector Models 103A02 and 103A12 since the radial wire leads of the Model 103A and 103A11 would interfere with the clamp nut. The installation drawing gives detailed instructions on preparation of the port for this type of installation.

3.1 ELECTRICAL

For the Models 103A and 103A11 (pigtail models), connect the center conductor from the "Xducer" output of any ICP® power unit to the white (Pwr/Sig) lead and connect the outer shell of the "Xducer" connector to the black (ground) lead. The black lead is electrically connected to the outer case. (See figure below.)

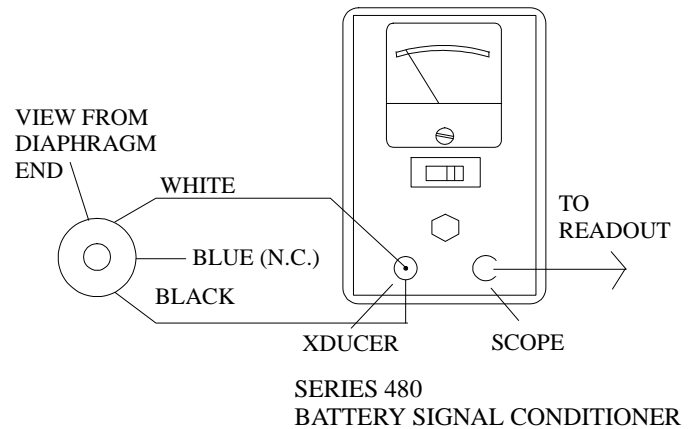

Models 103A & All: Electrical Connection

NOTE: No electrical connection is made to the blue (vent) lead. This lead serves to vent internal pressure within the sensor when the 103A and 103A11 are used in evacuated chambers. The internal pressure bleeds out slowly around the wires of this lead. This lead may be cut off flush with body if the sensor will never be used in this manner.

To make the electrical connection to the Models 103A02 and 103A12 (top connector models), simply connect the "Xducer" output of the power unit to the 10-32 coaxial connector using a PCB Model 002C Series coaxial cable.

The output signal is taken from the power unit connector labeled "Scope" or "Output". (See figure below.)

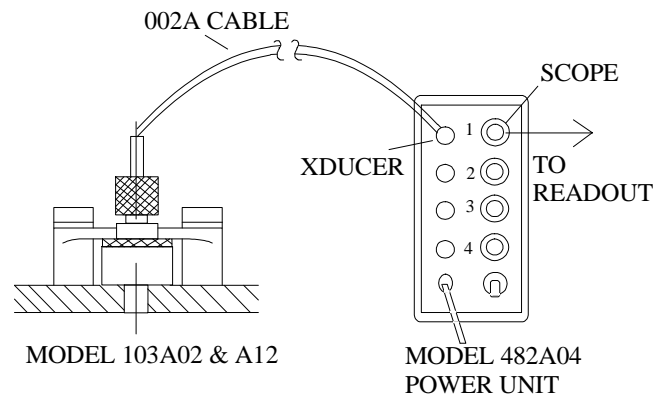

Models 103A02 & A12: Electrical Connection

OPERATION MANUAL FOR
MICROPHONE
Series 103A

Refer to Guide G-0001B for tips on power and signal utilization.

NOTE: The internal low-noise amplifier in the Model 103A, A02, A11 and A12 differ from the standard ICP[®] amplifiers described in Guide G-0001B in that the turn-on (or bias) voltage is nominally +4 volts.

Proper turn-on for Models 103A02, A11 and A1 2 will not give center scale reading on the fault monitor meters found on most PCB signal conditioners but will show a reading of approximately 20% of F.S. on these meters. This puts it at the lower limit of the green (or normal) area of the meters. This is normal and in no way indicates faulty operation.

4.0 OUTPUT SIGNAL

The output signal from the 103A Series is a voltage proportional to input pressure. The polarity is positive-going for increasing input pressure.

The signal is of high enough level and low enough output impedance to be fed directly into most oscilloscopes, tape recorders, strip chart recorders, A to D converters, etc.

Consult the factory for information regarding galvo driving since special amplifiers are needed to drive most high-current galvanometers.

Low-frequency response is limited by sensor discharge TC (given in the specification sheet) and by coupling time constants throughout the system. To take full advantage of the TC of the sensor, make sure that coupling TC's from power unit to readout are at least an order of magnitude longer than the discharge TC or use a direct-coupled signal conditioner such as the Model 484B. Consult factory for details.

5.0 CALIBRATION

The 103A Series Sensors must be dynamically calibrated using a known step function or pulse, or with a microphone calibrator.

At PCB, the units are subjected to various calibrated steps of pneumatic pressure to obtain a linearity curve over the full range of the instruments.

6.0 MAINTENANCE AND REPAIR

The small size and sealed construction of the Series 103A precludes field maintenance and repair.

Should the time constant degrade or an abnormality appear in the normal bias voltage, bake the unit out in a +250° F oven for 1 to 2 hours, then re-test.

If this is not effective or if other problems should occur, contact the factory for assistance in tracing the problem or for instructions on returning the unit for repair.

7.0 PRECAUTIONS

- 1.) Do not apply voltage to the unit without a current-limiting device in the line such as incorporated in all PCB signal conditioners, (20 mA maximum) to do so will destroy the internal amplifier.
- 2.) Do not subject these units to temperatures higher than 250° F.
- 3.) Do not attempt to disassemble these units as to do so voids the warranty.
- 4.) Use caution when removing units that have been mounted with epoxies or other strong adhesives. Excessive squeezing or torquing may damage the units and/or cause a calibration shift.
- 5.) In vibratory environments, secure cables and leads to surrounding structures to avoid lead or cable damage.
- 6.) Do not over torque when using the Servo clamps or the clamp nut since this could damage the units.
- 7.) Do not overpressure (see specs for maximum pressure), to do so may change the calibration.

	ENGLISH	SI	
Performance			
Measurement Range	3.00 psi	180.3 dB	
Useful Overrange	6.00 psi	186.3 dB	[1]
Sensitivity(± 15 %)	1,500 mV/psi	217.5 mV/kPa	
Maximum Pressure	250 psi	1,724 kPa	
Resolution	0.02 mpsi	77 dB	[2]
Resonant Frequency	≥ 13 kHz	≥ 13 kHz	
Rise Time	≤ 25 μ sec	≤ 25 μ sec	
Low Frequency Response(- 5 %)	5 Hz	5 Hz	
Non-Linearity	≤ 2.0 % FS	≤ 2.0 % FS	[3]
Environmental			
Acceleration Sensitivity	0.0005 psi/g	0.0035 kPa/(m/s ²)	[2]
Temperature Range(Operating)	-100 to 250 °F	-73 to 121 °C	
Temperature Coefficient of Sensitivity	≤ 0.2 %/°F	≤ 0.36 %/°C	
Maximum Flash Temperature	1,000 °F	538 °C	
Maximum Shock	1,000 g pk	9,807 m/s ² pk	
Maximum Vibration	1,000 g pk	9,807 m/s ² pk	
Electrical			
Discharge Time Constant	0.1 to 2.0 sec	0.1 to 2.0 sec	
Excitation Voltage	20 to 30 VDC	20 to 30 VDC	
Constant Current Excitation	2 to 20 mA	2 to 20 mA	
Output Impedance	≤ 100 Ohm	≤ 100 Ohm	
Output Bias Voltage	7 to 13 VDC	7 to 13 VDC	
Physical			
Sensing Element	Ceramic	Ceramic	
Housing Material	Stainless Steel	Stainless Steel	
Diaphragm	316L Stainless Steel	316L Stainless Steel	
Sealing	Epoxy	Epoxy	
Electrical Connector	Integral Cable	Integral Cable	
Cable Termination	Pigtail Ends	Pigtail Ends	
Weight	0.115 oz	3.260 gm	
Cable Type	32 AWG stranded wires	32 AWG stranded wires	
Cable Length	15 in	38.1 cm	

OPTIONAL VERSIONS

Optional versions have identical specifications and accessories as listed for the standard model except where noted below. More than one option may be used.

M - Metric Mount
Supplied Accessory: Model M061A04 Clamp (2)

NOTES:

[1] For +10 volt output, minimum 24 VDC supply voltage required. Negative 10 volt output may be limited by output bias.

[2] Typical.

[3] Zero-based, least-squares, straight line method.

[4] See PCB Declaration of Conformance PS023 for details.

SUPPLIED ACCESSORIES:

Model 061A04 Sleeve clamp 4-40 cap screw (2)
 Model 065A66 Adhesive Mounting Ring (3)
 Model 070B09 Solder adaptor
 Model PCS-1 Calibration of dynamic pressure sensors at 100% full scale, max 15 kpsi range.
 Model PCS-24 Sensor sensitivity calibration with Pistonphone

Entered: ND	Engineer: AJA	Sales: RWM	Approved: RPF	Spec Number:
Date: 08/13/2024	Date: 08/13/2024	Date: 08/13/2024	Date: 08/13/2024	24845

Phone: 716-684-0001
Fax: 716-684-0987
E-Mail: info@pcb.com

AN AMPHENOL COMPANY

3425 Walden Avenue, Depew, NY 14043



All specifications are at room temperature unless otherwise specified.
 In the interest of constant product improvement, we reserve the right to change specifications without notice.
 ICP® is a registered trademark of PCB Piezotronics, Inc.

24844

PCB Piezotronics Inc. claims proprietary rights in the information disclosed herein. Neither it nor any reproduction thereof will be disclosed to others without the written consent of PCB Piezotronics Inc.

REVISIONS		
REV	DESCRIPTION	DIN
B	UPDATED TITLE BLOCK	50900

INSTALLED WITHOUT "O-RING"

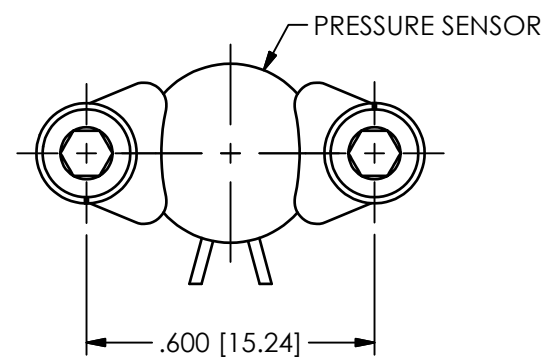

INSTALLED WITH ADHESIVE MOUNTING RING

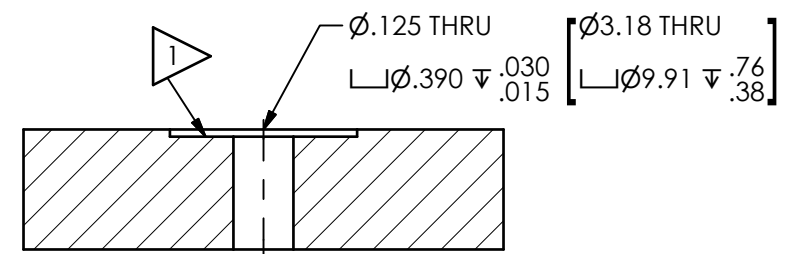
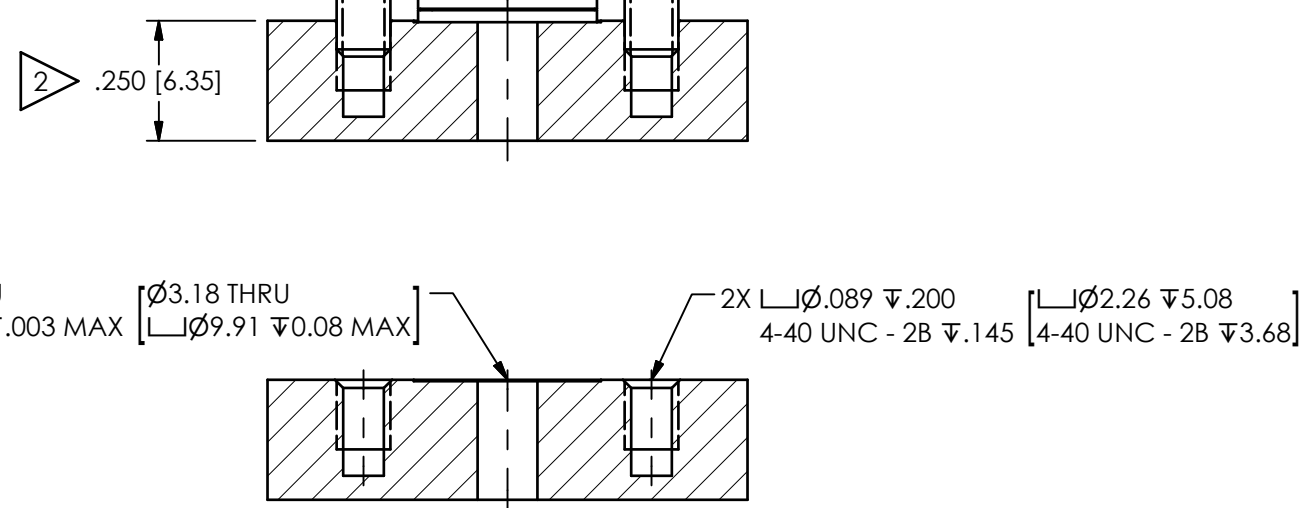
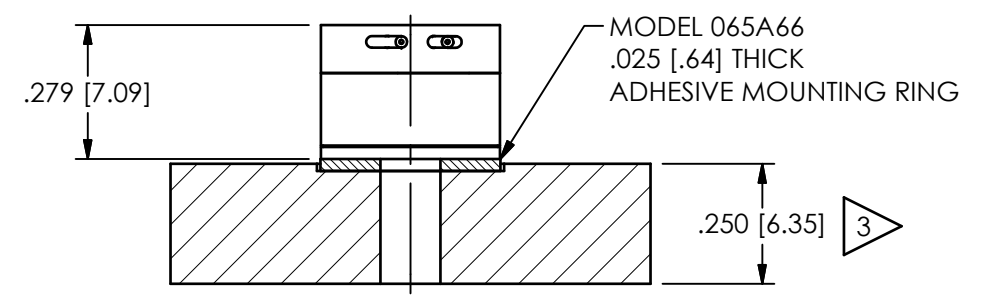
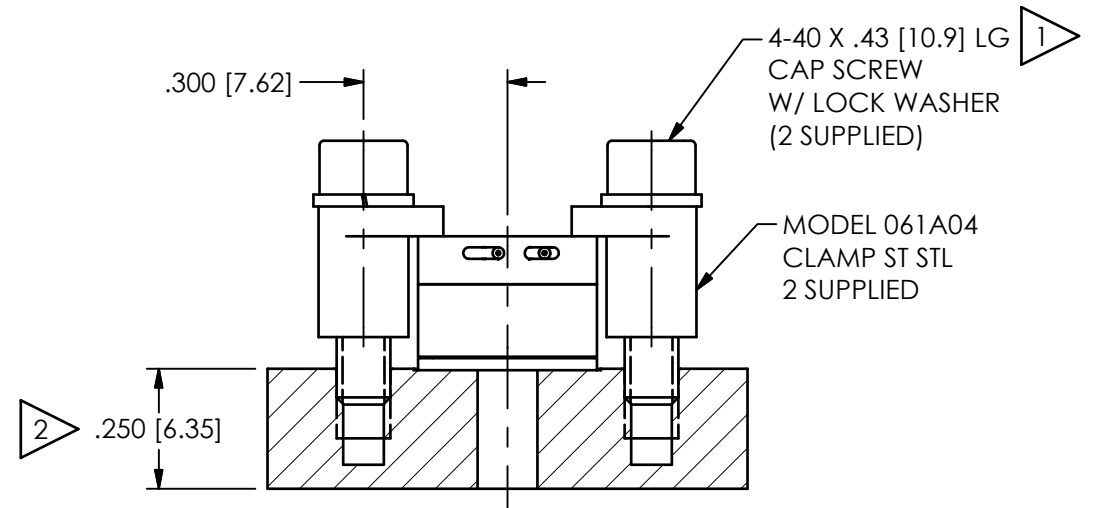
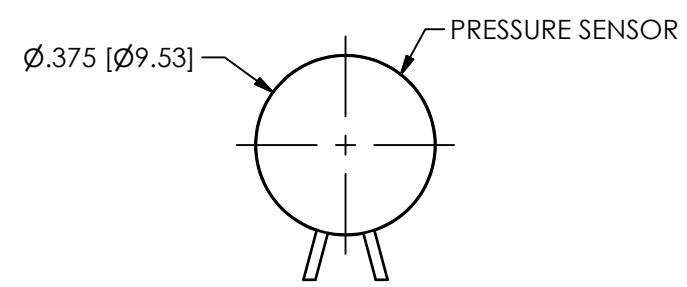

3) PREP SURFACE WITH A Ø.500[12.70] SPOTFACE, .015-.030 [.38-.76] x, 32 FINISH MIN. CENTER SPOTFACE TO .125[3.18]. APPLY 065A66 ADHESIVE MOUNTING RING, THEN SENSOR. LET SELF-CURE FOR 12 HRS. PRIOR TO TESTING. MAKE SURE SURFACE IS FREE OF DIRT, OIL, AND DEBRIS BEFORE APPLICATION.

2.) PRESSURE SHOULD NOT EXCEED 20 PSI WHEN USING ADHESIVE MOUNTING RING

1) EXCEEDING THIS DIMENSION WILL START LOWERING FREQUENCY RESPONSE

2) EXCEEDING THIS DIMENSION WILL START LOWERING FREQUENCY RESPONSE
 1) MOUNTING TORQUE SHOULD BE BETWEEN 4-5 in-lbs [4.5-5.6 Nm]

UNLESS OTHERWISE SPECIFIED TOLERANCES ARE:		DRAWN		CHECKED		ENGINEER	
DIMENSIONS IN INCHES	DIMENSIONS IN MILLIMETERS [IN BRACKETS]	JDM	7/8/20	JDM	7/8/20	RF	7/8/20
DECIMALS XX ±.01 XXX ±.005	DECIMALS X ±.03 XX ±.013	TITLE INSTALLATION DRAWING PRESSURE SENSOR					
ANGLES ± 2 DEGREES	ANGLES ± 2 DEGREES						
FILLETS AND RADII .003 - .005	FILLETS AND RADII 0.07 - 0.13	CODE IDENT. NO. 52681		DWG. NO. 24844		SCALE: 2.5X SHEET 1 OF 1	

PCB PIEZOTRONICS™
 3425 WALDEN AVE. DEPEW, NY 14043
 (716) 684-0001 E-MAIL: sales@pcb.com



Model 070B09

**Solder connector adaptor (10-32 plug to solder terminal, straight pins for
Installation and Operating Manual**

**For assistance with the operation of this product,
contact PCB Piezotronics, Inc.**

**Toll-free: 800-828-8840
24-hour SensorLine: 716-684-0001
Fax: 716-684-0987
E-mail: info@pcb.com
Web: www.pcb.com**



Repair and Maintenance

PCB guarantees Total Customer Satisfaction through its “Lifetime Warranty Plus” on all Platinum Stock Products sold by PCB and through its limited warranties on all other PCB Stock, Standard and Special products. Due to the sophisticated nature of our sensors and associated instrumentation, **field servicing and repair is not recommended and, if attempted, will void the factory warranty.**

Beyond routine calibration and battery replacements where applicable, our products require no user maintenance. Clean electrical connectors, housings, and mounting surfaces with solutions and techniques that will not harm the material of construction. Observe caution when using liquids near devices that are not hermetically sealed. Such devices should only be wiped with a dampened cloth—never saturated or submerged.

In the event that equipment becomes damaged or ceases to operate, our Application Engineers are here to support your troubleshooting efforts 24 hours a day, 7 days a week. Call or email with model and serial number as well as a brief description of the problem.

Calibration

Routine calibration of sensors and associated instrumentation is necessary to maintain measurement accuracy. We recommend calibrating on an annual basis, after exposure to any extreme environmental influence, or prior to any critical test.

PCB Piezotronics is an ISO-9001 certified company whose calibration services are accredited by A2LA to ISO/IEC 17025, with full traceability to SI through N.I.S.T. In addition to our standard calibration services, we also offer specialized tests, including: sensitivity at elevated or cryogenic temperatures, phase response, extended high or low frequency response, extended range, leak testing, hydrostatic pressure testing, and others. For more information, contact your local PCB Piezotronics distributor, sales representative, or factory customer service representative.

Returning Equipment

If factory repair is required, our representatives will provide you with a Return Material Authorization (RMA) number, which we use to reference any information you have already provided and expedite the repair process. This number should be clearly marked on the outside of all returned package(s) and on any packing list(s) accompanying the shipment.

Contact Information

PCB Piezotronics, Inc.
3425 Walden Ave.
Depew, NY14043 USA
Toll-free: (800) 828-8840
24-hour SensorLine: (716) 684-0001
General inquiries: info@pcb.com
Repair inquiries: rma@pcb.com

For a complete list of distributors, global offices and sales representatives, visit our website, www.pcb.com.

Safety Considerations

This product is intended for use by qualified personnel who recognize shock hazards and are familiar with the precautions required to avoid injury. While our equipment is designed with user safety in mind, the protection provided by the equipment may be impaired if equipment is used in a manner not specified by this manual.

Discontinue use and contact our 24-Hour Sensorline if:

- Assistance is needed to safely operate equipment
- Damage is visible or suspected
- Equipment fails or malfunctions

For complete equipment ratings, refer to the enclosed specification sheet for your product.

Definition of Terms and Symbols

The following symbols may be used in this manual:



DANGER

Indicates an immediate hazardous situation, which, if not avoided, may result in death or serious injury.

**CAUTION**

Refers to hazards that could damage the instrument.

**NOTE**

Indicates tips, recommendations and important information. The notes simplify processes and contain additional information on particular operating steps.

The following symbols may be found on the equipment described in this manual:



This symbol on the unit indicates that high voltage may be present. Use standard safety precautions to avoid personal contact with this voltage.



This symbol on the unit indicates that the user should refer to the operating instructions located in the manual.



This symbol indicates safety, earth ground.



PCB工业监视和测量设备 - 中国RoHS2公布表

PCB Industrial Monitoring and Measuring Equipment - China RoHS 2 Disclosure Table

部件名称	有害物质					
	铅 (Pb)	汞 (Hg)	镉 (Cd)	六价铬 (Cr(VI))	多溴联苯 (PBB)	多溴二苯醚 (PBDE)
住房	0	0	0	0	0	0
PCB板	X	0	0	0	0	0
电气连接器	0	0	0	0	0	0
压电晶体	X	0	0	0	0	0
环氧	0	0	0	0	0	0
铁氟龙	0	0	0	0	0	0
电子	0	0	0	0	0	0
厚膜基板	0	0	X	0	0	0
电线	0	0	0	0	0	0
电缆	X	0	0	0	0	0
塑料	0	0	0	0	0	0
焊接	X	0	0	0	0	0
铜合金/黄铜	X	0	0	0	0	0
本表格依据 SJ/T 11364 的规定编制。						
0：表示该有害物质在该部件所有均质材料中的含量均在 GB/T 26572 规定的限量要求以下。						
X：表示该有害物质至少在该部件的某一均质材料中的含量超出 GB/T 26572 规定的限量要求。						
铅是欧洲RoHS指令2011/65/ EU附件三和附件四目前由于允许的豁免。						

CHINA RoHS COMPLIANCE

Component Name	Hazardous Substances					
	Lead (Pb)	Mercury (Hg)	Cadmium (Cd)	Chromium VI Compounds (Cr(VI))	Polybrominated Biphenyls (PBB)	Polybrominated Diphenyl Ethers (PBDE)
Housing	O	O	O	O	O	O
PCB Board	X	O	O	O	O	O
Electrical Connectors	O	O	O	O	O	O
Piezoelectric Crystals	X	O	O	O	O	O
Epoxy	O	O	O	O	O	O
Teflon	O	O	O	O	O	O
Electronics	O	O	O	O	O	O
Thick Film Substrate	O	O	X	O	O	O
Wires	O	O	O	O	O	O
Cables	X	O	O	O	O	O
Plastic	O	O	O	O	O	O
Solder	X	O	O	O	O	O
Copper Alloy/Brass	X	O	O	O	O	O

This table is prepared in accordance with the provisions of SJ/T 11364.

O: Indicates that said hazardous substance contained in all of the homogeneous materials for this part is below the limit requirement of GB/T 26572.

X: Indicates that said hazardous substance contained in at least one of the homogeneous materials for this part is above the limit requirement of GB/T 26572.

Lead is present due to allowed exemption in Annex III or Annex IV of the European RoHS Directive 2011/65/EU.

2

1

070-2090-90

APPLICATION

NEXT ASS'Y	USED ON	VAR

REVISIONS

REV	DESCRIPTION	ECN	APP'D
A	REVISED AND REDRAWN	3283	DM 7/99
B	UPDATE DRAWING	23771	DM 2/06

PCB Piezotronics Inc. claims proprietary rights in the information disclosed hereon. Neither it nor any reproduction thereof will be disclosed to others without the written consent of PCB Piezotronics Inc.

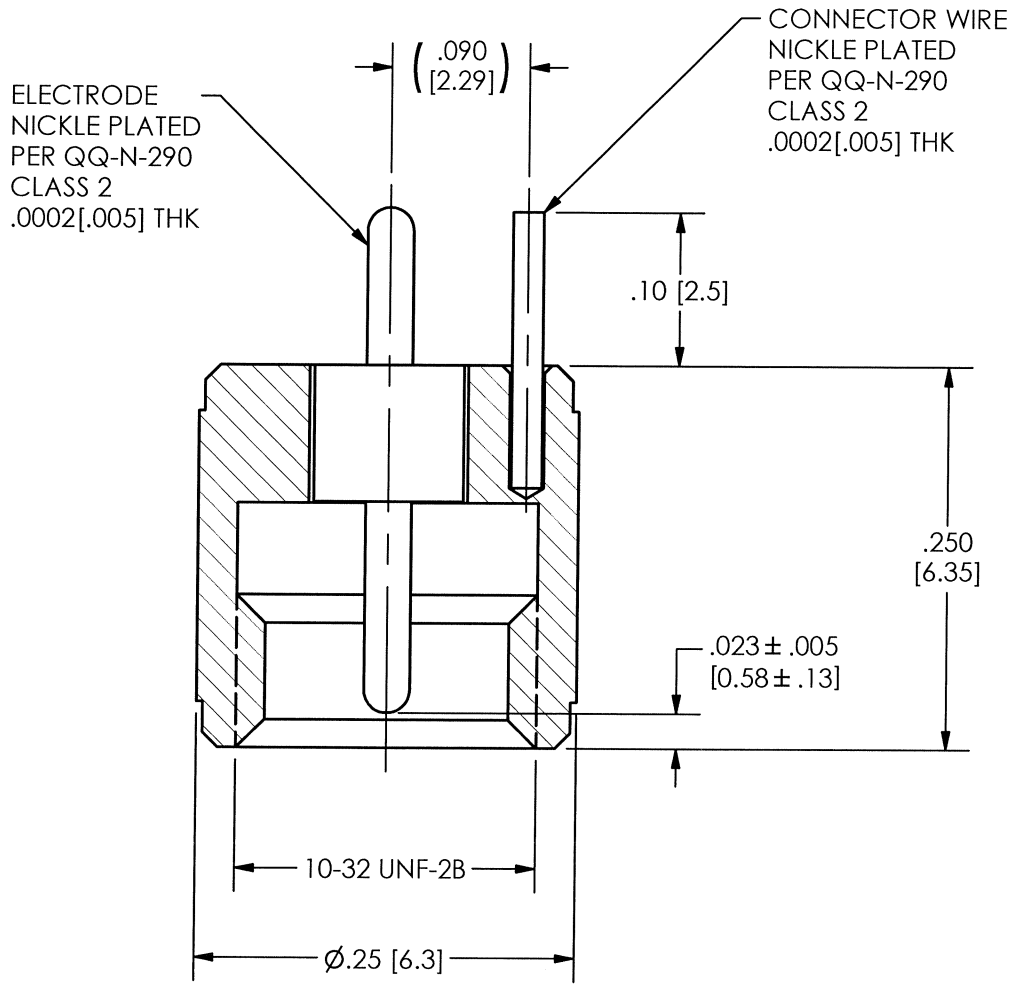

UNLESS OTHERWISE SPECIFIED TOLERANCES ARE:

DIMENSIONS IN INCHES	DIMENSIONS IN MILLIMETERS [IN BRACKETS]
DECIMALS XX ± .03	DECIMALS X ± 0.8
XXX ± .010	XX ± 0.25
ANGLES ± 2 DEGREES	ANGLES ± 2 DEGREES

DRAWN	ECB 2/27/06	MFG	RC 2/28/06
CHK'D	DM 2/27/06	ENGR	ECB 2/27/06
APP'D	RE 3/13/06	SALES	DPC 3/13/06

PCB PIEZOTRONICS INC.
 3425 WALDEN AVE. DEPEW, NY 14043
 (716) 684-0001 E-MAIL: sales@pcb.com

TITLE
OUTLINE DRAWING
MODEL 070B09
SOLDER CONNECTOR ADAPTOR

CODE IDENT. NO. 52681	DWG. NO. 070-2090-90
SCALE: 8X	SHEET 1 OF 1

2

1