



Model 483C05

Eight-Channel, ICP® Sensor Signal Conditioner

Installation and Operating Manual

**For assistance with the operation of this product,
contact PCB Piezotronics, Inc.**

**Toll-free: 800-828-8840
24-hour SensorLine: 716-684-0001
Fax: 716-684-0987
E-mail: info@pcb.com
Web: www.pcb.com**



Repair and Maintenance

PCB guarantees Total Customer Satisfaction through its “Lifetime Warranty Plus” on all Platinum Stock Products sold by PCB and through its limited warranties on all other PCB Stock, Standard and Special products. Due to the sophisticated nature of our sensors and associated instrumentation, **field servicing and repair is not recommended and, if attempted, will void the factory warranty.**

Beyond routine calibration and battery replacements where applicable, our products require no user maintenance. Clean electrical connectors, housings, and mounting surfaces with solutions and techniques that will not harm the material of construction. Observe caution when using liquids near devices that are not hermetically sealed. Such devices should only be wiped with a dampened cloth—never saturated or submerged.

In the event that equipment becomes damaged or ceases to operate, our Application Engineers are here to support your troubleshooting efforts 24 hours a day, 7 days a week. Call or email with model and serial number as well as a brief description of the problem.

Calibration

Routine calibration of sensors and associated instrumentation is necessary to maintain measurement accuracy. We recommend calibrating on an annual basis, after exposure to any extreme environmental influence, or prior to any critical test.

PCB Piezotronics is an ISO-9001 certified company whose calibration services are accredited by A2LA to ISO/IEC 17025, with full traceability to SI through N.I.S.T. In addition to our standard calibration services, we also offer specialized tests, including: sensitivity at elevated or cryogenic temperatures, phase response, extended high or low frequency response, extended range, leak testing, hydrostatic pressure testing, and others. For more information, contact your local PCB Piezotronics distributor, sales representative, or factory customer service representative.

Returning Equipment

If factory repair is required, our representatives will provide you with a Return Material Authorization (RMA) number, which we use to reference any information you have already provided and expedite the repair process. This number should be clearly marked on the outside of all returned package(s) and on any packing list(s) accompanying the shipment.

Contact Information

PCB Piezotronics, Inc.
3425 Walden Ave.
Depew, NY14043 USA
Toll-free: (800) 828-8840
24-hour SensorLine: (716) 684-0001
General inquiries: info@pcb.com
Repair inquiries: rma@pcb.com

For a complete list of distributors, global offices and sales representatives, visit our website, www.pcb.com.

Safety Considerations

This product is intended for use by qualified personnel who recognize shock hazards and are familiar with the precautions required to avoid injury. While our equipment is designed with user safety in mind, the protection provided by the equipment may be impaired if equipment is used in a manner not specified by this manual.

Discontinue use and contact our 24-Hour Sensorline if:

- Assistance is needed to safely operate equipment
- Damage is visible or suspected
- Equipment fails or malfunctions

For complete equipment ratings, refer to the enclosed specification sheet for your product.

Definition of Terms and Symbols

The following symbols may be used in this manual:



DANGER

Indicates an immediate hazardous situation, which, if not avoided, may result in death or serious injury.

**CAUTION**

Refers to hazards that could damage the instrument.

**NOTE**

Indicates tips, recommendations and important information. The notes simplify processes and contain additional information on particular operating steps.

The following symbols may be found on the equipment described in this manual:



This symbol on the unit indicates that high voltage may be present. Use standard safety precautions to avoid personal contact with this voltage.



This symbol on the unit indicates that the user should refer to the operating instructions located in the manual.



This symbol indicates safety, earth ground.



PCB工业监视和测量设备 - 中国RoHS2公布表

PCB Industrial Monitoring and Measuring Equipment - China RoHS 2 Disclosure Table

部件名称	有害物质					
	铅 (Pb)	汞 (Hg)	镉 (Cd)	六价铬 (Cr(VI))	多溴联苯 (PBB)	多溴二苯醚 (PBDE)
住房	0	0	0	0	0	0
PCB板	X	0	0	0	0	0
电气连接器	0	0	0	0	0	0
压电晶体	X	0	0	0	0	0
环氧	0	0	0	0	0	0
铁氟龙	0	0	0	0	0	0
电子	0	0	0	0	0	0
厚膜基板	0	0	X	0	0	0
电线	0	0	0	0	0	0
电缆	X	0	0	0	0	0
塑料	0	0	0	0	0	0
焊接	X	0	0	0	0	0
铜合金/黄铜	X	0	0	0	0	0
本表格依据 SJ/T 11364 的规定编制。						
0：表示该有害物质在该部件所有均质材料中的含量均在 GB/T 26572 规定的限量要求以下。						
X：表示该有害物质至少在该部件的某一均质材料中的含量超出 GB/T 26572 规定的限量要求。						
铅是欧洲RoHS指令2011/65/ EU附件三和附件四目前由于允许的豁免。						

CHINA RoHS COMPLIANCE

Component Name	Hazardous Substances					
	Lead (Pb)	Mercury (Hg)	Cadmium (Cd)	Chromium VI Compounds (Cr(VI))	Polybrominated Biphenyls (PBB)	Polybrominated Diphenyl Ethers (PBDE)
Housing	O	O	O	O	O	O
PCB Board	X	O	O	O	O	O
Electrical Connectors	O	O	O	O	O	O
Piezoelectric Crystals	X	O	O	O	O	O
Epoxy	O	O	O	O	O	O
Teflon	O	O	O	O	O	O
Electronics	O	O	O	O	O	O
Thick Film Substrate	O	O	X	O	O	O
Wires	O	O	O	O	O	O
Cables	X	O	O	O	O	O
Plastic	O	O	O	O	O	O
Solder	X	O	O	O	O	O
Copper Alloy/Brass	X	O	O	O	O	O

This table is prepared in accordance with the provisions of SJ/T 11364.

O: Indicates that said hazardous substance contained in all of the homogeneous materials for this part is below the limit requirement of GB/T 26572.

X: Indicates that said hazardous substance contained in at least one of the homogeneous materials for this part is above the limit requirement of GB/T 26572.

Lead is present due to allowed exemption in Annex III or Annex IV of the European RoHS Directive 2011/65/EU.

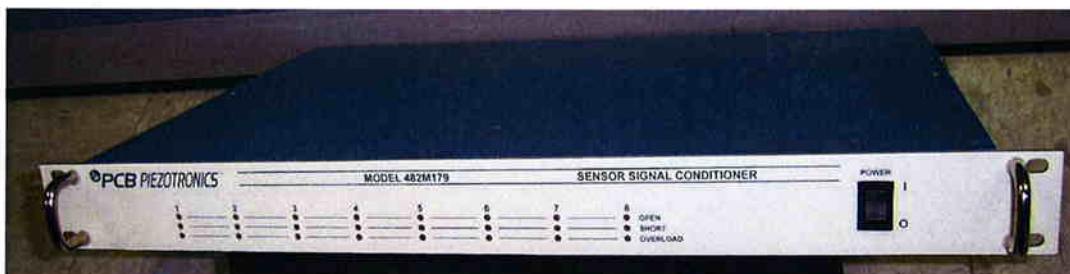

SIGNAL CONDITIONER

Models 483C05/483C15

GENERAL OPERATION MANUAL

For powering ICP[®] sensors and in-line charge converters, this signal conditioner provides a cost effective method for powering large numbers of sensor channels.

The 483C Series is available with many different options from PCB. This manual describes the functions of the most economical signal conditioner with unity gain (483C05) and x1, x10, x100 jumper selectable gain (483C15), of that series.



PCB PIEZOTRONICS, INC. 3425 WALDEN AVENUE DEPEW, NY 14043-2495 PHONE 716-684-0001 FAX 716-684-0987

[®]ICP is a registered trademark of PCB Group, Inc.

KS398

Table of Contents

Table of Contents	i
1-1. Introduction	1
1-2. Safety Considerations	1
1-3. Equipment Rating	2
1-4. Model 483C15 System Description	2
1-5. Model 483C05 System Description	4
1-6. Installation	4
1-7. Grounding Techniques	4
1-8. Unit Power	5
1-9. Maintenance and Repair	5
Appendix	
Specification Sheet	
Outline Drawing	

Manual Number: 38548
Manual Revision: NR
ECO Number:

1-1. Introduction

The Model 483C05 is a basic ICP[®] signal conditioner that provides an adjustable current source to drive ICP[®] sensors. Additionally it has Open, Short and Overload Input fault condition indicators.

The Model 483C15 is an ICP[®] signal conditioner that has all the features of the 483C05 plus jumper selectable (x1, x10, and x100) Gain options and an Overload range selection. An easy to open cover, allows access to the jumper selections.

The following sections describe these devices in more detail.

1-2. Safety Considerations

WARNING SYMBOLS AND TERMS

The following symbols and terms may be found on the equipment described in this manual.



This symbol on the unit indicates that the user should refer to the operating instructions located in the manual.



This symbol on the unit indicates that high voltage may be present. Use standard safety precautions to avoid personal contact with this voltage.



This symbol indicates that the test fixture, Model 483C15/483C05, must be connected to earth ground via the power cord.

The **WARNING** heading used in this manual explains dangers that might result in personal injury or death. Always read the associated information very carefully before performing the indicated procedure.

The **CAUTION** heading used in this manual explains hazards that could damage the instrument.

WARNING 1: *The power supply/signal conditioner should not be opened by anyone other than qualified service personnel.* This product is intended for service by qualified personnel who recognize shock hazards and are familiar with the safety precautions required to avoid injury.

WARNING 2: This equipment is designed with user safety in mind; however, the protection provided by the equipment may be impaired if the equipment is used in a manner not specified by PCB Piezotronics, Inc.

CAUTION 1: *Cables can kill your equipment.* High voltage ElectroStatic Discharge (ESD) can damage electrical devices. Similar to a capacitor, a cable can hold a charge caused by triboelectric transfer, such as that which occurs in the following:

- Laying on and moving across a rug.
- Any movement through air.
- The action of rolling out a cable.
- Contact to a non-grounded person

The solution for product safety: 1) Connect the cables only with the AC power off. 2) Temporarily “short” the end of the cable before attaching it to any signal input or output.

CAUTION 2: *ESD considerations should be made prior to performing any internal adjustments on the equipment.* Any piece of electronic equipment is vulnerable to ESD when opened for adjustments. Internal adjustments should therefore be done ONLY at an ESD-safe work area. Many products have ESD protection, but the level of protection may be exceeded by extremely high voltage that is typically present in normal situations.

1-3. Equipment Rating

For complete specifications, please refer to the enclosed Specification Sheet. This equipment operates optimally at +32 to +120°F (0 to +50°C), in an environment having <85% relative humidity. Its line power frequency range is 47-63 Hz.

The 483C15/483C05 devices require 100-240 VAC with 0.7A to operate. In turn, they supply 26 VDC @ 2 to 20 mA excitation voltage to connected ICP® sensors or in-line charge converters. The units get power via Standard IEC AC power cord PCB Model 017AXX.

1-4. Model 482C15 System Description

The Model 483C15 is a eight channel signal conditioning rack mount unit designed to interface measurement signals to readout or recording devices.

The following are features that come standard on 483C15 units:

- Input fault and overload LED's with jumper selectable overload level of +/-5V or +/-10V
- Variable ICP® source current, 0 to 20 mA
- Jumper selectable Voltage input mode
- Jumper selectable gain of x1, x10, x100 (483C15 Only)
- Lighted power indicator on the front panel
- Rear panel BNC input/output connectors
- Optional L.P. plug in filters (477A series type) various 2-pole frequencies avail. Consult factory
- Rack mountable enclosure.

1-4.1. Model 483C15 ICP® Input/Output Mode

The Model 483C15 contains a regulated 26 VDC power supply that provides constant current for up to 8 individual channels. Both the output and input connections utilize BNC connectors and are brought out through the rear panel. The unit is AC coupled only. The 482C series offers optional DC Coupling. Consult factory

1-4.2. Adjusting the Current Source

The Current adjustments are located on the rear of the unit. Use a standard small flat screwdriver to adjust the "I ADJ" potentiometers. Turning the adjustment slot clockwise will increase the current, while counterclockwise will decrease the current. Do this adjustment only while a DC mA meter or DMM set to mA is connected to any of the group of 4 "ICP" BNC's. One adjustment controls 4 channels. The unit is factory set to 4mA and can be adjusted between 0mA-20mA.

1-4.3. Fault Indications

The three red LED's on the front panel are all indicators of some type of problem. The normal good operation state is when all fault lights are off. The "OPEN" light indicates that the Bias voltage is over that of most sensors and is close to an open circuit voltage of 26VDC. The "SHORT" light indicates a very low Bias voltage close to 0VDC. The

“OVERLOAD” light indicates a signal level of +/-10V Peak has been detected and the signal may be in danger of clipping. These fault lights are active for all channels, at the same time.

1-4.4. Gain selection / Jumper definition

The 483C15 has internal jumpers that are accessed by opening the top cover. Remove all the Phillips screws, allowing the cover to be opened. The various jumpers are all labeled on the PC Boards. Each channel can be set to your selected gain and other options. The selection of all these features with jumpers allows the 483C15 to have the functionality of many other higher priced units. See the table that explains the function and number of each jumper. Place the blue jumpers in various locations as shown below.

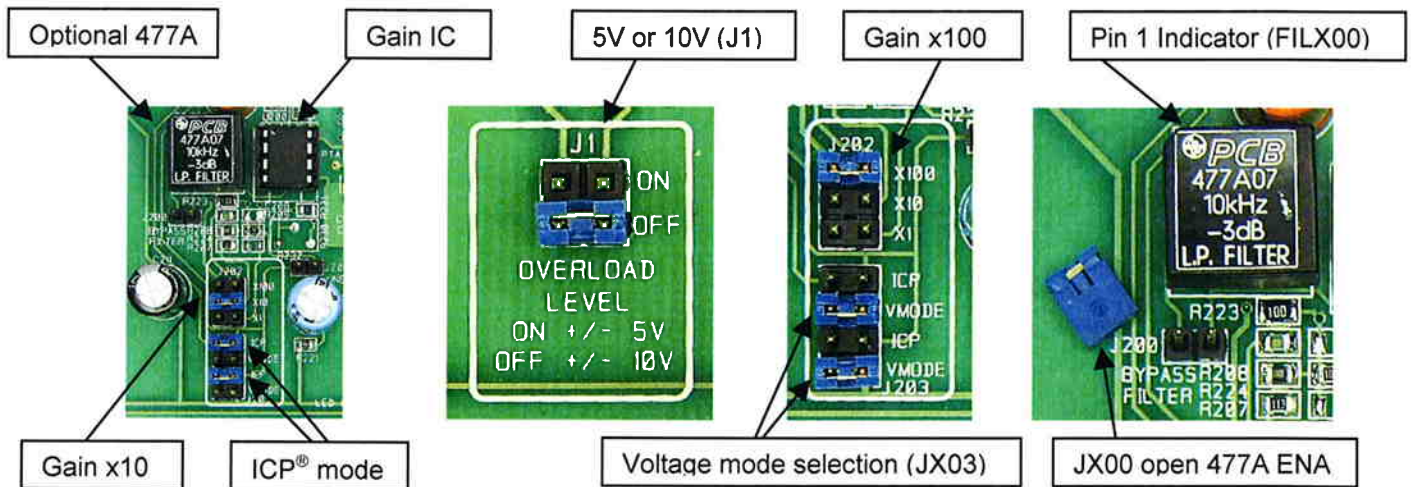

. “X” represents channel number on each bd. Channels 5-8 are controlled by the bd. on the right side of the unit.

Gain 1 10 100	JX02	1 jumper per channel
Overload 5V/10V	J1	Controls all channels
Voltage Mode	JX03	2 jumpers per channel
Bypass Filter	JX00	Remove to install filter module
477A Filter	FILX00	Install filter here per channel

1-5. Model 483C05 System Description

The Model 483C05 is a basic eight channel signal conditioning rack mount unit designed to interface measurement signals to readout or recording devices.

The following are features that come standard on every 483C05:

- Unity gain
- Input fault and overload LED's
- Variable ICP® source current, 0 to 20 mA
- Lighted power indicator on the front panel
- Rear panel BNC input/output connectors
- Rack mountable enclosure.

1-5.1. Model 483C05 ICP® Input/Output Mode

The Model 483C05 contains a regulated 26 VDC power supply that provides constant current for up to 8 individual channels. Both the output and input connections utilize BNC connectors and are brought out through the rear panel. The unit is AC coupled only. The 482C series offers optional DC Coupling. Consult factory

1-5.2. Adjusting the Current Source

The Current adjustments are located on the rear of the unit. Use a standard small flat screwdriver to adjust the "I ADJ" potentiometers. Turning the adjustment slot clockwise will increase the current, while counterclockwise will decrease the current. Do this adjustment only while a DC mA meter or DMM set to mA is connected to any of the group of 4 "ICP" BNC's. One adjustment controls 4 channels. The unit is factory set to 4mA and can be adjusted between 0mA-20mA.

1-5.3. Fault Indications

The three red LED's on the front panel are all indicators of some type of problem. The normal good operation state is when all fault lights are off. The "OPEN" light indicates that the Bias voltage is over that of most sensors and is close to an open circuit voltage of 26VDC. The "SHORT" light indicates a very low Bias voltage close to 0VDC. The "OVERLOAD" light indicates a signal level of +/-10V Peak has been detected and the signal may be in danger of clipping. These fault lights are active for all channels, at the same time.

1-6. Installation

Both the Model 483C15 and the Model 483C05 come packaged in a standard 19" 1U rack mount enclosure and require very little in term of installation. The box should be located in such a way as to allow convenient access to the power outlet for disconnect purposes. Since these units have low power consumption, they can be located in confined environments.

NOTE: Specific installation is available; contact PCB

1-7. Grounding Techniques

Integrating either of these Models into an application that links the outputs to other test equipment powered by line voltages may lead to errors or loss of signal-to-noise ratio due to ground loops. The evidence of ground loops is easily seen whenever the fundamental frequency (50 or 60 Hz) or a multiple of the fundamental frequency is present in the system when the sensors are “at rest.” In order to maintain the operating specification of noise and reduce the effects of line interference, proper grounding techniques should be used. The following procedure may be helpful:

1. Make sure the signal ground lines of all equipment are tied together. The signal grounds of the channels are typically tied together via the case of the input and output BNC connectors. The individual channels of the Model 483C15 and 483C05 have their signal ground line tied together internally at the power supply.
2. Insure that the sensor does not pick up line noise from the body under test. The case of the sensor should be isolated from the body under (ground) using an isolation pad. The isolation pad breaks the loop formed by the signal path of the sensor to the unit and the return (ground) from the unit back to the sensor.
3. Make sure that all equipment signal grounds of the test system are tied to the Earth ground at a single point and the connections linking the equipment ground are made using a wire that can provide a very low impedance connection.

1-8. Unit Power

1-8.1. Power: Standard AC Line power

Plug the unit into any 100-240VAC 47-63Hz power source, attach the supplied ferrite clamp on the AC cord to ensure CE conformance, and press the “ON/OFF” – “IN/OUT” switch.

CAUTION 3: Refer to the rear panel for proper input voltage. Standard IEC 320 input connector with internal fuse.

1-9. Maintenance and Repair

It is not recommended that the customer attempt repairs of the Model 483C15 or 483C05. Should trouble occur, contact the factory for assistance.

Performance	<u>ENGLISH</u>	<u>SI</u>	
Channels	8	8	
Sensor Input Type(s)	ICP®	ICP®	
Output Range(Maximum)	± 10 V	± 10 V	
Low Frequency Response(-5 %)	<0.1 Hz	<0.1 Hz	[2][3]
High Frequency Response(-5 %)	>1000 kHz	>1000 kHz	
Phase Response(at 1 kHz)	± 1 °	± 1 °	
Cross Talk(maximum)	-72 dB	-72 dB	
Fault/Bias Monitor/Meter(LED)	Open/Short/Overload	Open/Short/Overload	
Environmental			
Temperature Range(Operating)	+32 to +122 °F	0 to +50 °C	
Electrical			
Power Required	AC Power	AC Power	
AC Power(47 to 63 Hz)	100 to 240 VAC	100 to 240 VAC	
AC Power	≤ 0.7 Amps	≤ 0.7 Amps	
Excitation Voltage(± 1 VDC)(To Sensor)	+26 VDC	+26 VDC	
DC Offset	<20 mV	<20 mV	
Constant Current Excitation(To Sensor)	0 to 20 mA	0 to 20 mA	[1]
Overload Threshold(± 1.0 Vpk)	± 10 Vpk	± 10 Vpk	
Discharge Time Constant(0 to 50 %)	>5 sec	>5 sec	[2][3]
Broadband Electrical Noise(1 to 10,000 Hz)	3.5 µV rms	3.5 µV rms	[4]
Spectral Noise(1 Hz)	1.30 µV/√Hz	1.30 µV/√Hz	[4]
Spectral Noise(10 Hz)	0.10 µV/√Hz	0.10 µV/√Hz	[4]
Spectral Noise(100 Hz)	0.08 µV/√Hz	0.08 µV/√Hz	[4]
Spectral Noise(1 kHz)	0.07 µV/√Hz	0.07 µV/√Hz	[4]
Spectral Noise(10 kHz)	0.07 µV/√Hz	0.07 µV/√Hz	[4]
Physical			
Electrical Connector(ICP® Sensor Input)	BNC Jack	BNC Jack	
Electrical Connector(Output)	BNC Jack	BNC Jack	
Electrical Connector(AC Power Input)	IEC 320	IEC 320	
Size (Height x Width x Depth)(nominal)	1.75 in x 19 in x 13.7 in	44.5. mm x 482.6 mm x 348 mm	
Weight	6.25 lb	2.83 kg	

OPTIONAL VERSIONS

Optional versions have identical specifications and accessories as listed for the standard model except where noted below. More than one option may be used.

NOTES:

[1]User adjustable, factory set at 4 mA (± 0.5 mA). Each control adjusts 4 channels.
 [2]With ≥ 1M ohm input impedance of readout device.
 [3]Un-buffered output, read out device input impedance affects discharge time constant and low frequency response of unit.
 [4]Typical.
 [5]See PCB Declaration of Conformance PS024 for details.

SUPPLIED ACCESSORIES:
 Model 017AXX Power Cord (1)

Entered: AP	Engineer: CPH	Sales: ML	Approved: JWH	Spec Number:
Date: 1/28/2015	Date: 1/28/2015	Date: 1/28/2015	Date: 1/28/2015	38547



All specifications are at room temperature unless otherwise specified.
 In the interest of constant product improvement, we reserve the right to change specifications without notice.
 ICP® is a registered trademark of PCB Group, Inc.



Phone: 716-684-0001
Fax: 716-684-0987
E-Mail: info@pcb.com

PCB Piezotronics Inc. claims proprietary rights in the information disclosed hereon. Neither it nor any reproduction thereof will be disclosed to others without the written consent of PCB Piezotronics Inc.

38442

REVISIONS		
REV	DESCRIPTION	DIN
B	UPDATED DIMENSIONS TO 1.75,18.3,1.25	40833

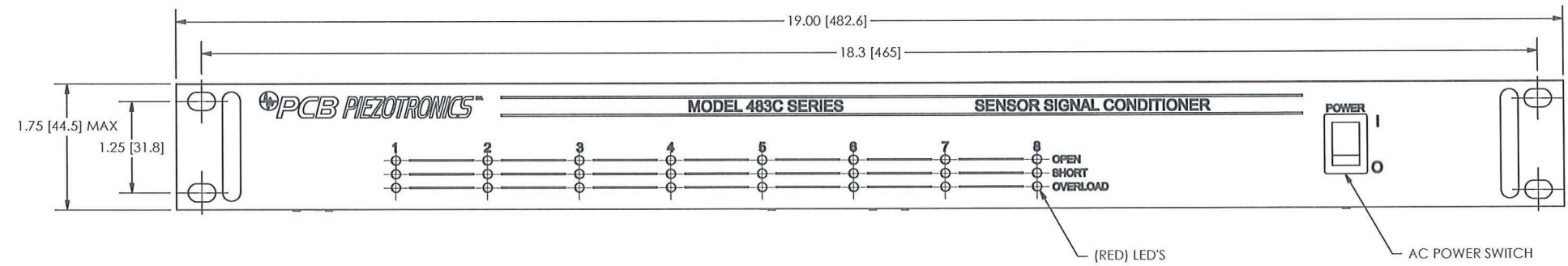
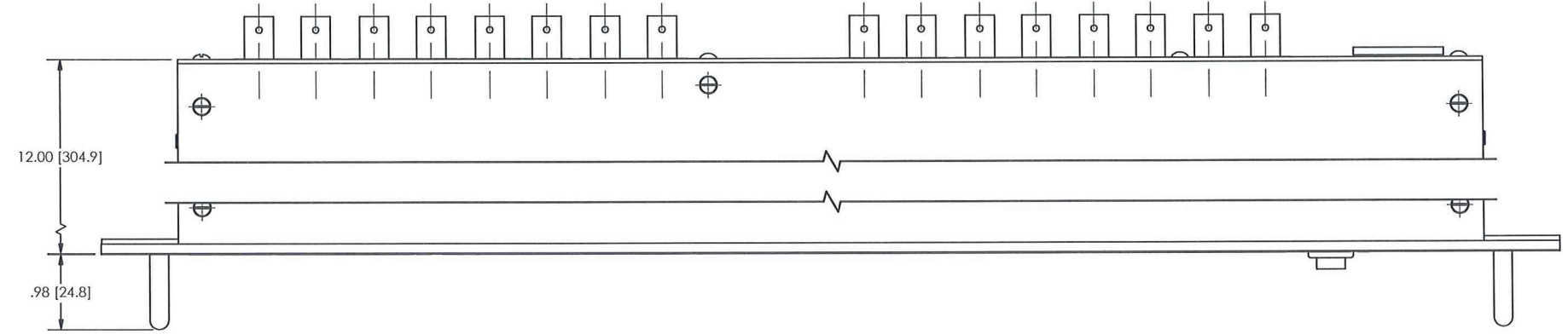
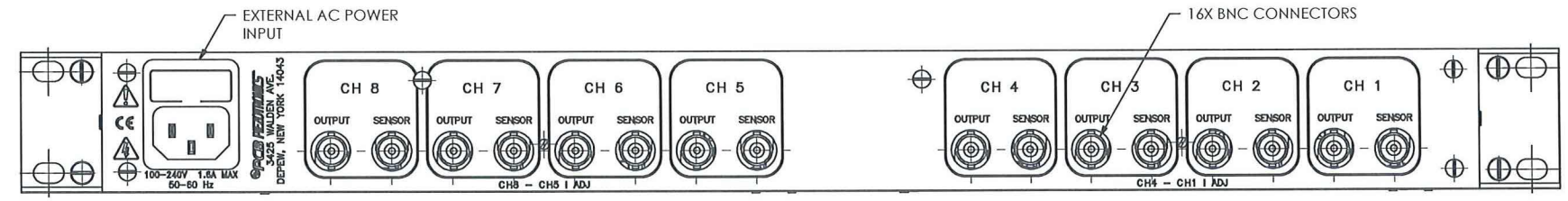

UNLESS OTHERWISE SPECIFIED TOLERANCES ARE:		DRAWN	CHECKED	ENGINEER
DIMENSIONS IN INCHES	DIMENSIONS IN MILLIMETERS [IN BRACKETS]	JDM	3/27/13	AJP
DECIMALS XX ±.03 XXX ±.010	DECIMALS X ±0.8 XX ±0.25	 TITLE OUTLINE DRAWING MODEL 483C05/15 SENSOR SIGNAL CONDITIONER		
ANGLES ± 2 DEGREES	ANGLES ± 2 DEGREES	CODE IDENT. NO. 52681 DWG. NO. 38442 SCALE: .75X SHEET 1 OF 1		
FILLETS AND RADI .003 - .005	FILLETS AND RADI 0.07 - 0.13	 3425 WALDEN AVE. DEPEW, NY 14043 (716) 684-0001 E-MAIL: sales@pcb.com		