

PCB Piezotronics Inc. claims proprietary rights in the information disclosed hereon. Neither it nor any reproduction thereof will be disclosed to others without the written consent of PCB Piezotronics Inc.

1 REVISIONS		
REV	DESCRIPTION	DIN
F	ADDED .600 DIMENSIONS	50594

8915

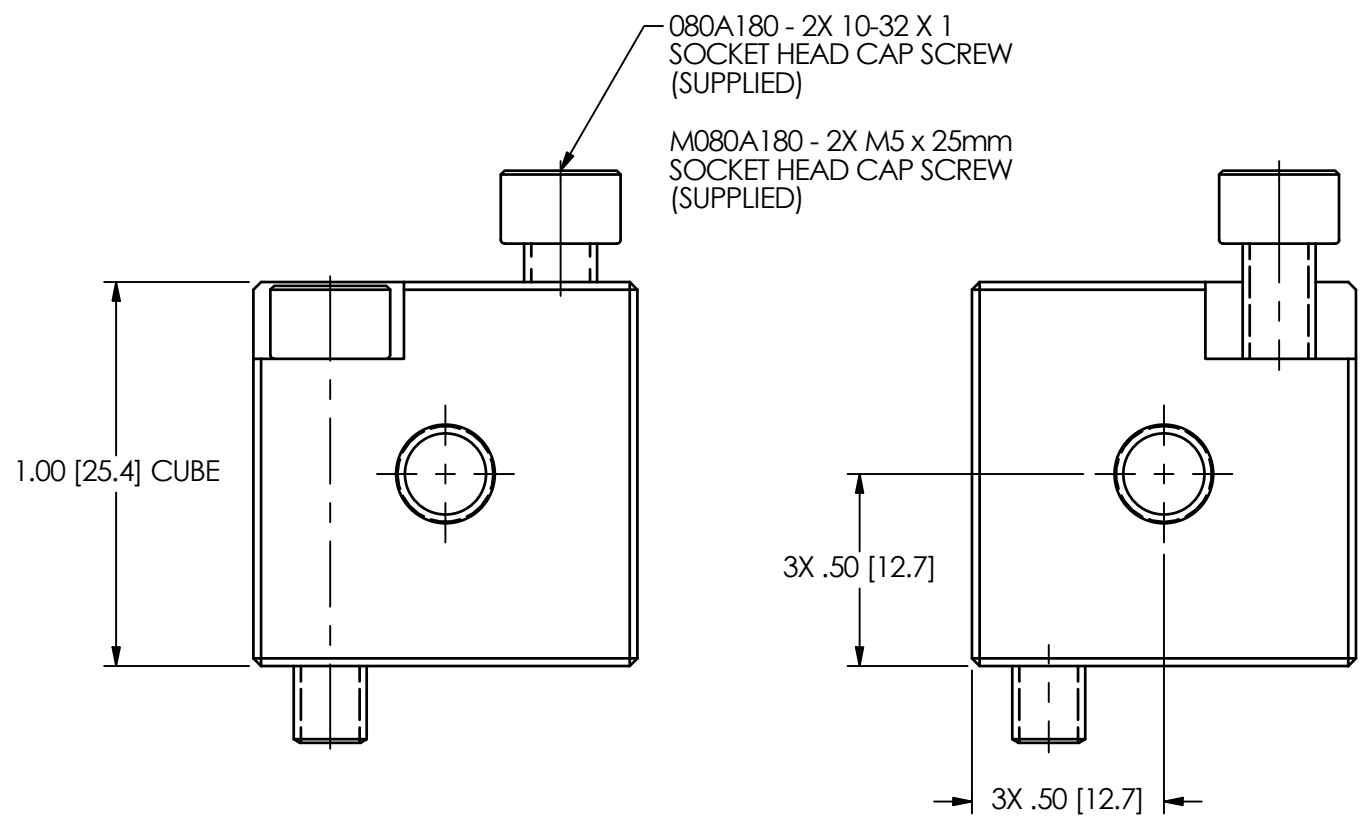
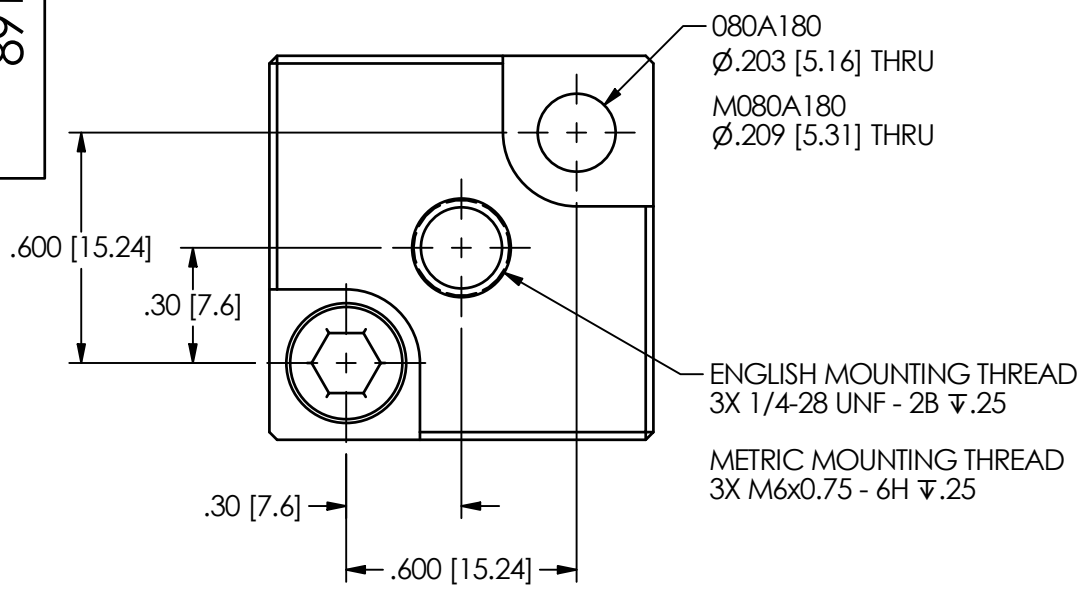

UNLESS OTHERWISE SPECIFIED TOLERANCES ARE:		DRAWN		CHECKED		ENGINEER		 3425 WALDEN AVE. DEPEW, NY 14043 (716) 684-0001 E-MAIL: sales@pcb.com	
DIMENSIONS IN INCHES	DIMENSIONS IN MILLIMETERS [IN BRACKETS]	JJF	3/17/20	JJF	3/17/20	BAM	3/17/20		
DECIMALS XX $\pm.03$ XXX $\pm.010$	DECIMALS X ± 0.8 XX ± 0.25	TITLE OUTLINE DRAWING MODEL 080A180 (M) TRIAXIAL MOUNTING BLOCK							CODE IDENT. NO. 52681
ANGLES ± 2 DEGREES	ANGLES ± 2 DEGREES								DWG. NO. 8915
FILLETS AND RADII .003 - .005	FILLETS AND RADII 0.07 - 0.13	SCALE: 2X	SHEET 1 OF 1						

2

1