

PCB Piezotronics Inc. claims proprietary rights in the information disclosed hereon. Neither it nor any reproduction thereof will be disclosed to others without the written consent of PCB Piezotronics Inc.

70536

REVISIONS		
REV	DESCRIPTION	DIN
NR	RELEASED TO DRAFTING	49223

FRONT VIEW OF CONNECTOR
SCALE 5X

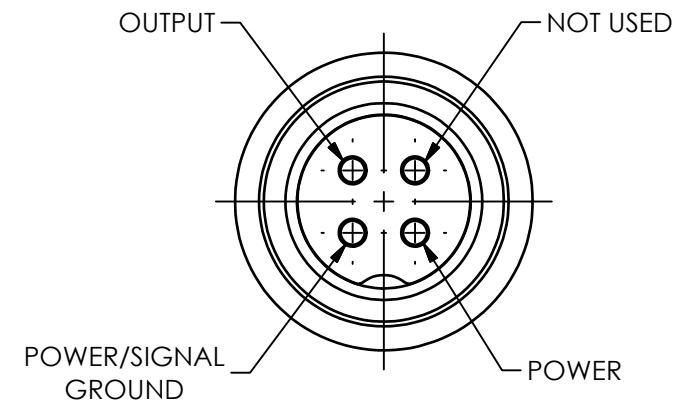

OUTPUT SIGNAL:
REFERENCE TO GROUND

POWER:
CONNECT TO DC VOLTAGE
POWER SUPPLY, SEE
SPECIFICATION SHEET FOR
PROPER EXCITATION
VOLTAGE

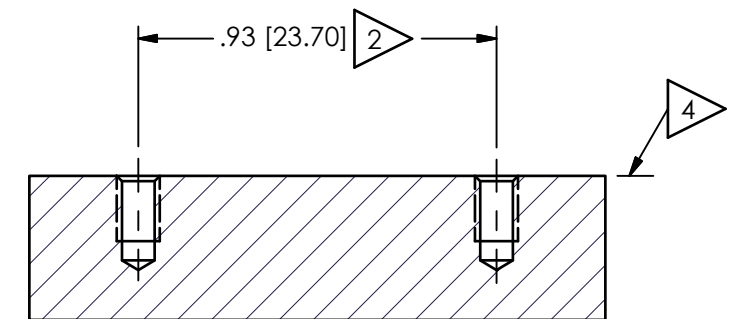
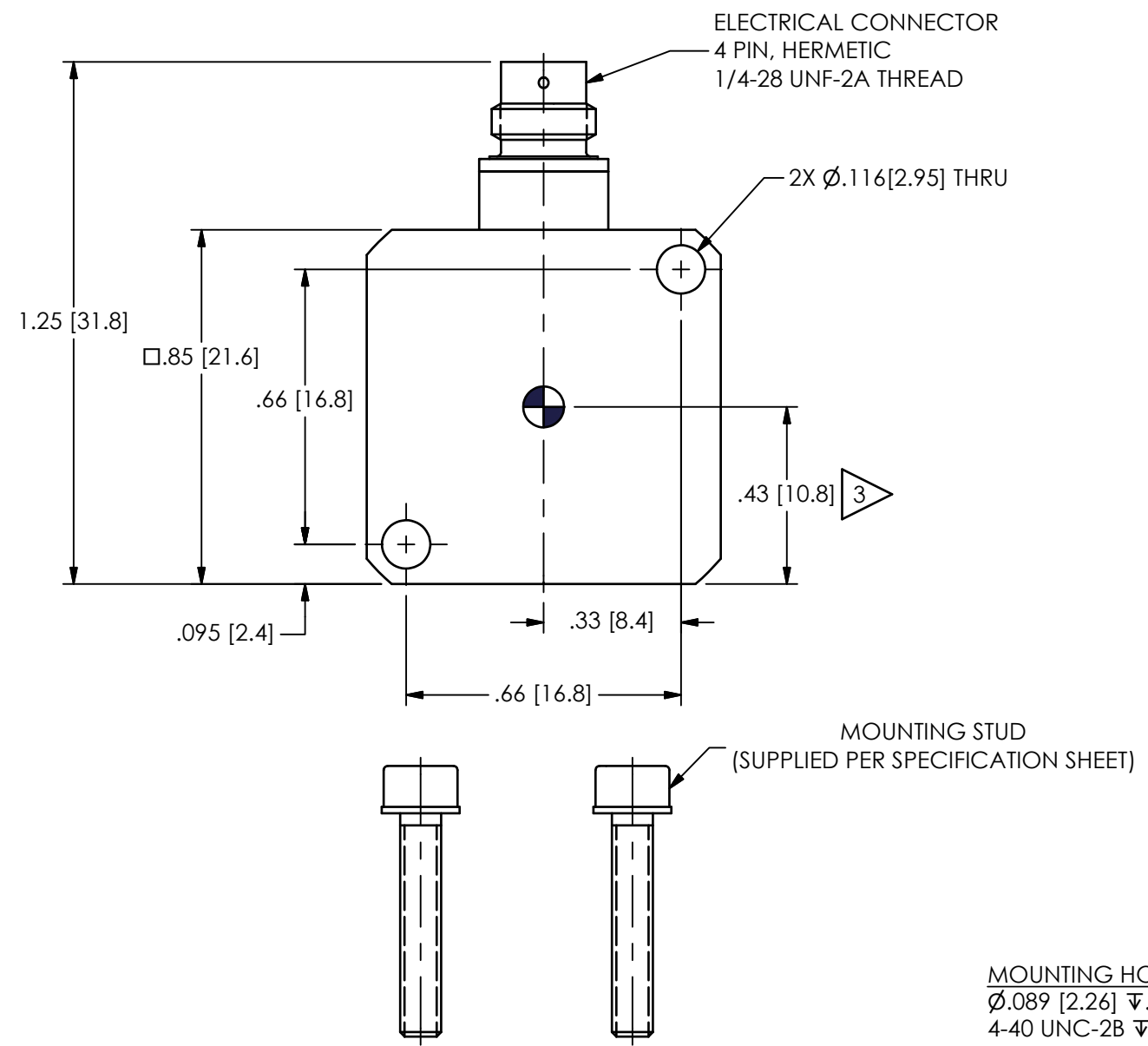

MOUNTING HOLE PREPARATION:
Ø.089 [2.26] ∇ .220 [5.59] MIN
4-40 UNC-2B ∇ .170 [4.32] MIN

METRIC MOUNTING HOLE PREPARATION:
Ø.081 [2.05] ∇ .180 [4.57] MIN
M2.5 X .45-6H ∇ .130 [3.30] MIN

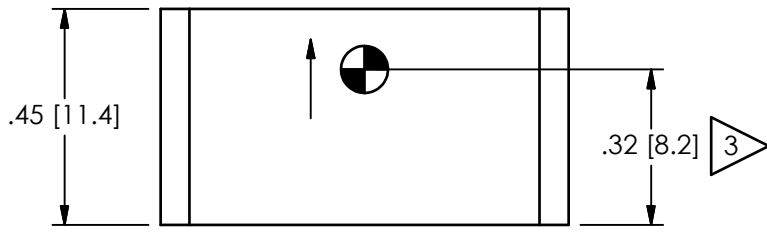

5.) SEE SHEET 2 OF 2 FOR CABLE STRAIN RELIEF INFORMATION

4 RECOMMENDED MOUNTING SURFACE SHOULD BE FLAT TO WITHIN .003 [.08] TIR OVER Ø1.21 [30.5] WITH A FINISH OF 32[.08] FOR BEST RESULTS

3 CG-CENTER OF SEISMIC MEASUREMENT

2 DIAGONAL MOUNTING DIMENSION BETWEEN HOLES

1 RECOMMENDED MOUNTING TORQUE ON MOUNTING STUD, 4-5 IN-LBS [45-55 N-CM]

UNLESS OTHERWISE SPECIFIED TOLERANCES ARE:		DRAWN		CHECKED		ENGINEER		PCB PIEZOTRONICS™	
DIMENSIONS IN INCHES	DIMENSIONS IN MILLIMETERS [IN BRACKETS]	JES	3/20/19	JDM	3/20/19	NF	3/20/19	3425 WALDEN AVE. DEPEW, NY 14043 (716) 684-0001 E-MAIL: sales@pcb.com	
DECIMALS XX ±.01 XXX ±.005	DECIMALS X ±.03 XX ±.013	TITLE INSTALLATION DRAWING MODEL 3711F SERIES DC ACCELEROMETER						CODE IDENT. NO. 52681	DWG. NO. 70536
ANGLES ± 2 DEGREES	ANGLES ± 2 DEGREES							SCALE: 2X	SHEET 1 OF 2
FILLETS AND RADII .003 - .005	FILLETS AND RADII 0.07 - 0.13								

70536

PCB Piezotronics Inc. claims proprietary rights in the information disclosed hereon. Neither it nor any reproduction thereof will be disclosed to others without the written consent of PCB Piezotronics Inc.

REVISIONS		
REV	DESCRIPTION	DIN
	- SEE SHEET 1 -	

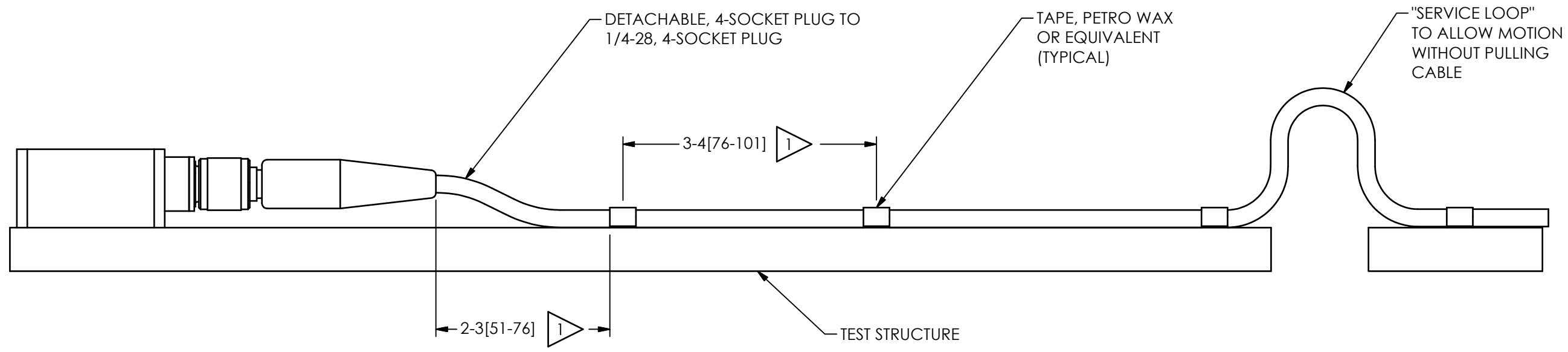

1 FASTEN CABLE TO TEST STRUCTURE TYPICALLY WITHIN 2-3" [51-76] OF SENSOR. THEN FASTEN AGAIN WITHIN 3-4" [76-101] OF PREVIOUS ATTACHMENT. BETWEEN THE TEST STRUCTURE AND A FIXED STRUCTURE, ALLOW A SERVICE LOOP LARGE ENOUGH TO PREVENT PULLING OF THE CABLE WHEN SHAKING. MORE ATTACHMENT POINTS WILL PROVIDE LESS NOISE IN THE RESULTING DATA. LOOSE CABLES OR PARTS ELSEWHERE ON THE TEST STRUCTURE CAN ALSO GENERATE "NOISE" ON THE SIGNAL RECEIVED FROM THE MODEL 3711 SERIES.

UNLESS OTHERWISE SPECIFIED TOLERANCES ARE:		DRAWN		CHECKED		ENGINEER	
DIMENSIONS IN INCHES	DIMENSIONS IN MILLIMETERS [IN BRACKETS]	JES	3/20/19	JDM	3/20/19	NF	3/20/19
DECIMALS XX ±.01 XXX ±.005	DECIMALS X ±.03 XX ±.013	TITLE INSTALLATION DRAWING MODEL 3711F SERIES DC ACCELEROMETER					
ANGLES ± 2 DEGREES	ANGLES ± 2 DEGREES						
FILLETS AND RADII .003 - .005	FILLETS AND RADII 0.07 - 0.13	CODE IDENT. NO. 52681		DWG. NO. 70536		SCALE: 1.5X SHEET 2 OF 2	

PCB PIEZOTRONICS
3425 WALDEN AVE. DEPEW, NY 14043
(716) 684-0001 E-MAIL: sales@pcb.com