



Model 137B24A

Quartz, free-field, ICP® blast pressure pencil probe, 250 psi, 20 mV/psi, 10-32 connector

Installation and Operating Manual

**For assistance with the operation of this product,
contact the PCB Piezotronics, Inc.**

Toll-free: 716-684-0001

24-hour SensorLine: 716-684-0001

Fax: 716-684-0987

E-mail: info@pcb.com

Web: www.pcb.com



Repair and Maintenance

PCB guarantees Total Customer Satisfaction through its “Lifetime Warranty Plus” on all Platinum Stock Products sold by PCB and through its limited warranties on all other PCB Stock, Standard and Special products. Due to the sophisticated nature of our sensors and associated instrumentation, **field servicing and repair is not recommended and, if attempted, will void the factory warranty.**

Beyond routine calibration and battery replacements where applicable, our products require no user maintenance. Clean electrical connectors, housings, and mounting surfaces with solutions and techniques that will not harm the material of construction. Observe caution when using liquids near devices that are not hermetically sealed. Such devices should only be wiped with a dampened cloth—never saturated or submerged.

In the event that equipment becomes damaged or ceases to operate, our Application Engineers are here to support your troubleshooting efforts 24 hours a day, 7 days a week. Call or email with model and serial number as well as a brief description of the problem.

Calibration

Routine calibration of sensors and associated instrumentation is necessary to maintain measurement accuracy. We recommend calibrating on an annual basis, after exposure to any extreme environmental influence, or prior to any critical test.

PCB Piezotronics is an ISO-9001 certified company whose calibration services are accredited by A2LA to ISO/IEC 17025, with full traceability to SI through N.I.S.T. In addition to our standard calibration services, we also offer specialized tests, including: sensitivity at elevated or cryogenic temperatures, phase response, extended high or low frequency response, extended range, leak testing, hydrostatic pressure testing, and others. For more information, contact your local PCB Piezotronics distributor, sales representative, or factory customer service representative.

Returning Equipment

If factory repair is required, our representatives will provide you with a Return Material Authorization (RMA) number, which we use to reference any information you have already provided and expedite the repair process. This number should be clearly marked on the outside of all returned package(s) and on any packing list(s) accompanying the shipment.

Contact Information

PCB Piezotronics, Inc.
3425 Walden Ave.
Depew, NY14043 USA
Toll-free: (800) 828-8840
24-hour SensorLine: (716) 684-0001
General inquiries: info@pcb.com
Repair inquiries: rma@pcb.com

For a complete list of distributors, global offices and sales representatives, visit our website, www.pcb.com.

Safety Considerations

This product is intended for use by qualified personnel who recognize shock hazards and are familiar with the precautions required to avoid injury. While our equipment is designed with user safety in mind, the protection provided by the equipment may be impaired if equipment is used in a manner not specified by this manual.

Discontinue use and contact our 24-Hour Sensorline if:

- Assistance is needed to safely operate equipment
- Damage is visible or suspected
- Equipment fails or malfunctions

For complete equipment ratings, refer to the enclosed specification sheet for your product.

Definition of Terms and Symbols

The following symbols may be used in this manual:



DANGER

Indicates an immediate hazardous situation, which, if not avoided, may result in death or serious injury.

**CAUTION**

Refers to hazards that could damage the instrument.

**NOTE**

Indicates tips, recommendations and important information. The notes simplify processes and contain additional information on particular operating steps.

The following symbols may be found on the equipment described in this manual:



This symbol on the unit indicates that high voltage may be present. Use standard safety precautions to avoid personal contact with this voltage.



This symbol on the unit indicates that the user should refer to the operating instructions located in the manual.



This symbol indicates safety, earth ground.



PCB工业监视和测量设备 - 中国RoHS2公布表

PCB Industrial Monitoring and Measuring Equipment - China RoHS 2 Disclosure Table

部件名称	有害物质					
	铅 (Pb)	汞 (Hg)	镉 (Cd)	六价铬 (Cr(VI))	多溴联苯 (PBB)	多溴二苯醚 (PBDE)
住房	0	0	0	0	0	0
PCB板	X	0	0	0	0	0
电气连接器	0	0	0	0	0	0
压电晶体	X	0	0	0	0	0
环氧	0	0	0	0	0	0
铁氟龙	0	0	0	0	0	0
电子	0	0	0	0	0	0
厚膜基板	0	0	X	0	0	0
电线	0	0	0	0	0	0
电缆	X	0	0	0	0	0
塑料	0	0	0	0	0	0
焊接	X	0	0	0	0	0
铜合金/黄铜	X	0	0	0	0	0
本表格依据 SJ/T 11364 的规定编制。						
0：表示该有害物质在该部件所有均质材料中的含量均在 GB/T 26572 规定的限量要求以下。						
X：表示该有害物质至少在该部件的某一均质材料中的含量超出 GB/T 26572 规定的限量要求。						
铅是欧洲RoHS指令2011/65/ EU附件三和附件四目前由于允许的豁免。						

CHINA RoHS COMPLIANCE

Component Name	Hazardous Substances					
	Lead (Pb)	Mercury (Hg)	Cadmium (Cd)	Chromium VI Compounds (Cr(VI))	Polybrominated Biphenyls (PBB)	Polybrominated Diphenyl Ethers (PBDE)
Housing	O	O	O	O	O	O
PCB Board	X	O	O	O	O	O
Electrical Connectors	O	O	O	O	O	O
Piezoelectric Crystals	X	O	O	O	O	O
Epoxy	O	O	O	O	O	O
Teflon	O	O	O	O	O	O
Electronics	O	O	O	O	O	O
Thick Film Substrate	O	O	X	O	O	O
Wires	O	O	O	O	O	O
Cables	X	O	O	O	O	O
Plastic	O	O	O	O	O	O
Solder	X	O	O	O	O	O
Copper Alloy/Brass	X	O	O	O	O	O

This table is prepared in accordance with the provisions of SJ/T 11364.

O: Indicates that said hazardous substance contained in all of the homogeneous materials for this part is below the limit requirement of GB/T 26572.

X: Indicates that said hazardous substance contained in at least one of the homogeneous materials for this part is above the limit requirement of GB/T 26572.

Lead is present due to allowed exemption in Annex III or Annex IV of the European RoHS Directive 2011/65/EU.

OPERATION MANUAL FOR FREE FIELD BLAST PRESSURE PROBE Models 137B21X, B22X, B23X, B24X

1.0 INTRODUCTION

The Series 137B2XX Free Field Blast ICP[®] Pressure Probe is designed for measuring free field blast and shock tunnel pressure time profiles.

Designed with an ICP[®] built-in source follower amplifier, the 137B2XX Series offers sensitivities of 1, 20, 10 and 100 mV/psi with full-scale ranges from 0 to 50, 250, 500 or 5000 psi. The 137B2XX Series is constructed with a stable quartz piezoelectric element in an Invar housing



Photo 2

2.0 INSTALLATION

In field blast measurements, mount the Series 137B2XX pressure probe in an axial direction to the blast source. The probes should be elevated high enough off of the ground such that ground does not interfere with the measured pressure. See photo 1.

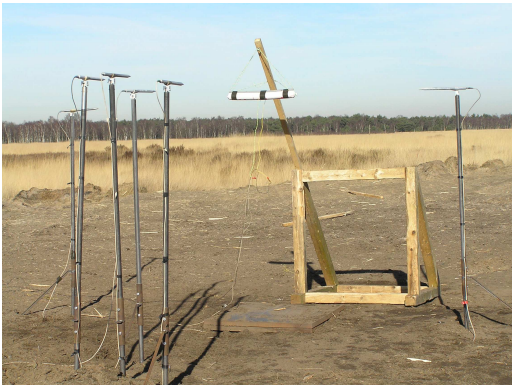

Photo 1

The sensing surface should be aligned in a vertical plane with respect to the ground as shown in photo 2. Avoiding direct exposure of the diaphragm to sunlight is good practice so that changing temperatures throughout a test day do not change the sensitivity of the sensor. In any case care must be taken such that the sensor's diaphragm is not oriented down to avoid ground reflections.

In some cases, where flash temperatures such as those generated by blasts and shock fronts are present, it may be necessary to thermally insulate the diaphragm to minimize signals generated by these effects.

Common black vinyl electrical tape has been found to be an effective thermal insulating material in many cases. One layer may be used across the end of diaphragm and adaptor. See photo 3.



Photo 3

A silicone rubber coating approximately 0.010 inch (0.25 mm) thick has also been proven effective in many applications. General Electric RTV type 106 is recommended (PCB Model 065A67). Apply the rubber coating to the surface of the diaphragm and allow it to cure in accordance with the manufacturer's instructions.

3.0 OPERATION

Using suitable cable, connect the sensor to one of PCB's Series 480, 481, 482, 483, or 484 signal conditioners or equivalent power supply. If using a PCB line power unit, the equipment will supply the 137B2XX with an adjustable 2 to 20 mA constant current at +22 to +30 VDC through a current-regulating circuit. If using a battery-operated unit, the constant current is 2 mA. See Guide G-0001 for powering and signal utilization information pertinent to all ICP[®] instrumentation.

**OPERATION MANUAL FOR
FREE FIELD BLAST PRESSURE PROBE
Models 137B21X, B22X, B23X, B24X**

Switch power on and observe reading of bias monitoring voltmeter on front panel of signal conditioner.

If indicator is in green section of indicator panel, the IC amplifier is producing proper bias (8 to 14 VDC), the cable connections are normal, and the system is ready to operate.

If the pointer moves into the red area of the fault monitor meter, output is zero and a short is indicated. The short could be located in amplifier cable connectors or power unit.

If the pointer moves into the yellow area of the fault monitor meter, an open circuit is indicated with full power supply voltage.

An open circuit could be the result of a faulty amplifier, an open cable or open connectors. Check to be sure connectors are properly mated. Some PCB power units feature fault LEDs in place of a fault meter. Instead of a pointer, the fault LED will light when an open or short circuit condition is present.

Allow the sensor to thermally stabilize for about one minute. A signal drift may occur when the cable is connected to the readout instrument. This drift occurs during charging of the coupling capacitor in the power unit. The signal will stabilize in several minutes. Proceed with measurements.

Most line-powered signal conditioners manufactured by PCB have an adjustable current feature allowing a choice of input currents from 2 to 20 mA. In general, for the lowest noise (best resolution), choose the lower current ranges.

In order to maintain a high frequency response of the system when driving long cables (to hundreds or thousands of feet), use a higher current, up to 20 mA maximum. Use of low-capacitance cable (i.e. RG 62/U) and impedance-matching variable resistors are suggested to improve long cable performance characteristics. See Guide G-0001 for a discussion on cable considerations.

3.1 POLARITY

The 137B2XX Series produces a positive-going output voltage for increasing pressure output.

4.0 LOW-FREQUENCY RESPONSE

Consult Section 7.0 in General Guide G-0001 for detailed explanation of low-frequency characteristics of ICP[®] instrumentation.

5.0 CALIBRATION

Do not try to calibrate the Series 137B2XX statically. The Series 137B2XX is calibrated dynamically by PCB using a hydraulic pulse technique.

For best accuracy, use the calibration certificate supplied. Factory recalibration is available for a nominal charge.

6.0 MAINTENANCE

Although ICP[®] sensors have low-output impedance and are not usually affected by moisture, in extremely damp environments it may be well to protect cable connections with shrink tubing.

It is well to observe the following precautions in using the sensor:

1. Do not exceed specified maximum range.
2. Do not subject sensor to temperatures exceeding temperature shown on specification sheet.
3. Do not apply voltage to sensor without current-limiting diodes or other current protection.
4. Do not apply more than 20 mA of current to the sensor.

Field repair of the piezoelectric element or amplifier of the Series 137B2XX is not practicable. Thus, should a sensor in this series require servicing, refer to the warranty sheet.

CAUTIONARY NOTE: If sensors are left outside overnight, they should be coated with silicone oil and covered. The protective silicone oil or grease coating should also be applied when the sensors are operated in a humid or rainy environment.

®ICP is a registered trademark of PCB Piezotronics

Model Number
137B24A

ICP® PRESSURE SENSOR

Revision: C
ECN #: 55416

	ENGLISH	SI	
Performance			
Measurement Range(for ±5V output)	250 psi	1,724 kPa	
Useful Overrange(for ± 10V output)	500 psi	3,447 kpsi	[1]
Sensitivity(± 15 %)	20 mV/psi	2.90 mV/kPa	
Maximum Pressure	5 kpsi	34,474 kPa	
Resolution	.7 mpsi	.005 kPa	[2]
Resonant Frequency	≥ 400 kHz	≥ 400 kHz	
Rise Time(Incident)	≤ 6.5 μ sec	≤ 6.5 μ sec	
Non-Linearity	≤ 1.0 % FS	≤ 1.0 % FS	[3]
Environmental			
Temperature Range(Operating)	-100 to +275 °F	-73 to +135 °C	
Temperature Coefficient of Sensitivity	≤ 0.05 %/°F	≤ 0.090 %/°C	
Electrical			
Discharge Time Constant(at room temp)	≥ 0.2 sec	≥ 0.2 sec	
Excitation Voltage	20 to 30 VDC	20 to 30 VDC	
Constant Current Excitation	2 to 20 mA	2 to 20 mA	
Output Impedance	≤ 200 Ohm	≤ 200 Ohm	
Output Bias Voltage	8 to 14 VDC	8 to 14 VDC	
Physical			
Sensing Geometry	Compression	Compression	
Sensing Element	Quartz	Quartz	
Housing Material	Aluminum	Aluminum	
Diaphragm	Invar	Invar	
Sealing	Epoxy	Epoxy	
Electrical Connector	10-32 Coaxial Jack	10-32 Coaxial Jack	
Weight	12.5 oz	354 gm	[2]

OPTIONAL VERSIONS

Optional versions have identical specifications and accessories as listed for the standard model except where noted below. More than one option may be used.

NOTES:

- [1] For +10 volt output, minimum 26 VDC supply voltage required. Negative 10 volt output may be limited by output bias.
- [2] Typical.
- [3] Zero-based, least-squares, straight line method.
- [4] See PCB Declaration of Conformance PS023 for details.

SUPPLIED ACCESSORIES:

Model 085A43 Connector Protector (1)
Model PCS-1AZ Sensitivity calibration at 100% and 10% of sensor range

Entered: ND	Engineer: RPF	Sales: MV	Approved: RPF	Spec Number:
Date: 12/14/2024	Date: 12/14/2024	Date: 12/14/2024	Date: 12/14/2024	55319



All specifications are at room temperature unless otherwise specified.
In the interest of constant product improvement, we reserve the right to change specifications without notice.
ICP® is a registered trademark of PCB Piezotronics, Inc.

PCB PIEZOTRONICS Phone: 716-684-0001
AN AMPHENOL COMPANY Fax: 716-684-0987
E-Mail: info@pcb.com

3425 Walden Avenue, Depew, NY 14043

PCB Piezotronics Inc. claims proprietary rights in the information disclosed hereon. Neither it nor any reproduction thereof will be disclosed to others without the written consent of PCB Piezotronics Inc.

REVISIONS

REV	DESCRIPTION	DIN
NR	RELEASED TO DRAFTING	37217

40953

B

B

A

A

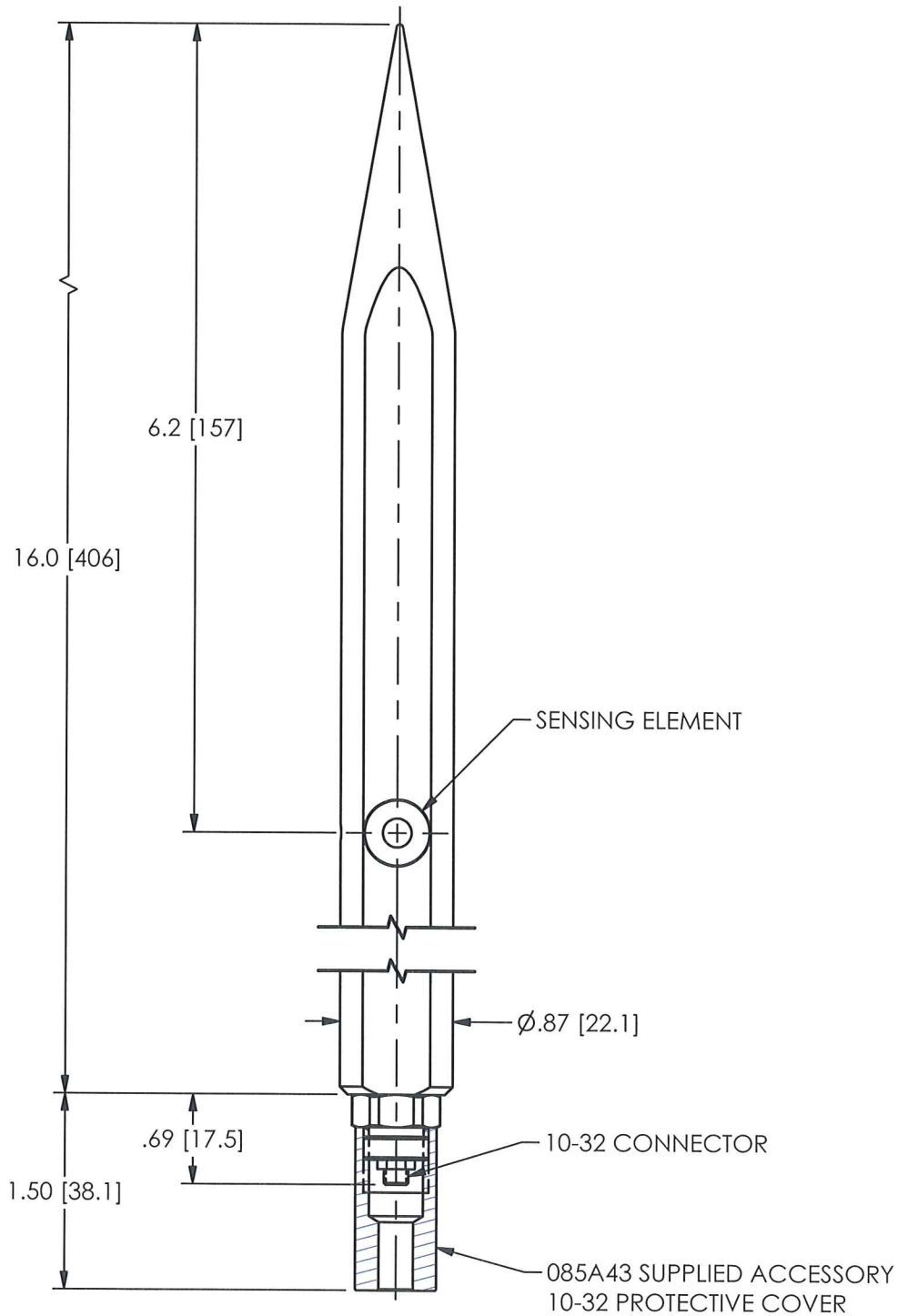

UNLESS OTHERWISE SPECIFIED TOLERANCES ARE:

DIMENSIONS IN INCHES	DIMENSIONS IN MILLIMETERS [IN BRACKETS]
DECIMALS XX ±.03 XXX ±.010	DECIMALS X ± 0.8 XX ± 0.25
ANGLES ± 2 DEGREES	ANGLES ± 2 DEGREES

FILLETS AND RADII
.003 - .005

FILLETS AND RADII
0.07 - 0.13

DRAWN		CHECKED		ENGINEER	
SMB	10/11/11	<i>[Signature]</i>	10/11/11	MJK	10/11/11

TITLE
OUTLINE DRAWING
MODEL 137BXXA SERIES
FREE FIELD BLAST PROBE

PCB PIEZOTRONICS INC.

3425 WALDEN AVE. DEPEW, NY 14043
(716) 684-0001 E-MAIL: sales@pcb.com

CODE IDENT. NO. 52681
DWG. NO. 40953

SCALE: .75X SHEET 1 OF 1