



## **Model 134A24**

**Tourmaline ICP® pressure bar with 003 cable and inline source follower, 1000 psi, 5 mV/psi, 0.2 microsecond rise time**

### **Installation and Operating Manual**

**This manual contains the 134-1010-01, 402A installation and operating manuals that comprise a Model 134A24 Tourmaline ICP® pressure bar with 003 cable and inline source follower, 1000 psi, 5 mV/psi, 0.2 microsecond rise time kit.**

**For assistance with the operation of this product,  
contact the PCB Piezotronics, Inc.**

**Toll-free: 716-684-0001  
24-hour SensorLine: 716-684-0001  
Fax: 716-684-0987  
E-mail: [info@pcb.com](mailto:info@pcb.com)  
Web: [www.pcb.com](http://www.pcb.com)**



## Repair and Maintenance

PCB guarantees Total Customer Satisfaction through its “Lifetime Warranty Plus” on all Platinum Stock Products sold by PCB and through its limited warranties on all other PCB Stock, Standard and Special products. Due to the sophisticated nature of our sensors and associated instrumentation, **field servicing and repair is not recommended and, if attempted, will void the factory warranty.**

Beyond routine calibration and battery replacements where applicable, our products require no user maintenance. Clean electrical connectors, housings, and mounting surfaces with solutions and techniques that will not harm the material of construction. Observe caution when using liquids near devices that are not hermetically sealed. Such devices should only be wiped with a dampened cloth—never saturated or submerged.

In the event that equipment becomes damaged or ceases to operate, our Application Engineers are here to support your troubleshooting efforts 24 hours a day, 7 days a week. Call or email with model and serial number as well as a brief description of the problem.

## Calibration

Routine calibration of sensors and associated instrumentation is necessary to maintain measurement accuracy. We recommend calibrating on an annual basis, after exposure to any extreme environmental influence, or prior to any critical test.

PCB Piezotronics is an ISO-9001 certified company whose calibration services are accredited by A2LA to ISO/IEC 17025, with full traceability to SI through N.I.S.T. In addition to our standard calibration services, we also offer specialized tests, including: sensitivity at elevated or cryogenic temperatures, phase response, extended high or low frequency response, extended range, leak testing, hydrostatic pressure testing, and others. For more information, contact your local PCB Piezotronics distributor, sales representative, or factory customer service representative.

## Returning Equipment

If factory repair is required, our representatives will provide you with a Return Material Authorization (RMA) number, which we use to reference any information you have already provided and expedite the repair process. This number should be clearly marked on the outside of all returned package(s) and on any packing list(s) accompanying the shipment.

## Contact Information

PCB Piezotronics, Inc.  
3425 Walden Ave.  
Depew, NY14043 USA  
Toll-free: (800) 828-8840  
24-hour SensorLine: (716) 684-0001  
General inquiries: [info@pcb.com](mailto:info@pcb.com)  
Repair inquiries: [rma@pcb.com](mailto:rma@pcb.com)

For a complete list of distributors, global offices and sales representatives, visit our website, [www.pcb.com](http://www.pcb.com).

## Safety Considerations

This product is intended for use by qualified personnel who recognize shock hazards and are familiar with the precautions required to avoid injury. While our equipment is designed with user safety in mind, the protection provided by the equipment may be impaired if equipment is used in a manner not specified by this manual.

Discontinue use and contact our 24-Hour Sensorline if:

- Assistance is needed to safely operate equipment
- Damage is visible or suspected
- Equipment fails or malfunctions

For complete equipment ratings, refer to the enclosed specification sheet for your product.

## Definition of Terms and Symbols

The following symbols may be used in this manual:



### DANGER

Indicates an immediate hazardous situation, which, if not avoided, may result in death or serious injury.

**CAUTION**

Refers to hazards that could damage the instrument.

**NOTE**

Indicates tips, recommendations and important information. The notes simplify processes and contain additional information on particular operating steps.

**The following symbols may be found on the equipment described in this manual:**



This symbol on the unit indicates that high voltage may be present. Use standard safety precautions to avoid personal contact with this voltage.



This symbol on the unit indicates that the user should refer to the operating instructions located in the manual.



This symbol indicates safety, earth ground.



PCB工业监视和测量设备 - 中国RoHS2公布表

PCB Industrial Monitoring and Measuring Equipment - China RoHS 2 Disclosure Table

部件名称	有害物质					
	铅 (Pb)	汞 (Hg)	镉 (Cd)	六价铬 (Cr(VI))	多溴联苯 (PBB)	多溴二苯醚 (PBDE)
住房	0	0	0	0	0	0
PCB板	X	0	0	0	0	0
电气连接器	0	0	0	0	0	0
压电晶体	X	0	0	0	0	0
环氧	0	0	0	0	0	0
铁氟龙	0	0	0	0	0	0
电子	0	0	0	0	0	0
厚膜基板	0	0	X	0	0	0
电线	0	0	0	0	0	0
电缆	X	0	0	0	0	0
塑料	0	0	0	0	0	0
焊接	X	0	0	0	0	0
铜合金/黄铜	X	0	0	0	0	0
本表格依据 SJ/T 11364 的规定编制。						
0：表示该有害物质在该部件所有均质材料中的含量均在 GB/T 26572 规定的限量要求以下。						
X：表示该有害物质至少在该部件的某一均质材料中的含量超出 GB/T 26572 规定的限量要求。						
铅是欧洲RoHS指令2011/65/ EU附件三和附件四目前由于允许的豁免。						

CHINA RoHS COMPLIANCE

Component Name	Hazardous Substances					
	Lead (Pb)	Mercury (Hg)	Cadmium (Cd)	Chromium VI Compounds (Cr(VI))	Polybrominated Biphenyls (PBB)	Polybrominated Diphenyl Ethers (PBDE)
Housing	O	O	O	O	O	O
PCB Board	X	O	O	O	O	O
Electrical Connectors	O	O	O	O	O	O
Piezoelectric Crystals	X	O	O	O	O	O
Epoxy	O	O	O	O	O	O
Teflon	O	O	O	O	O	O
Electronics	O	O	O	O	O	O
Thick Film Substrate	O	O	X	O	O	O
Wires	O	O	O	O	O	O
Cables	X	O	O	O	O	O
Plastic	O	O	O	O	O	O
Solder	X	O	O	O	O	O
Copper Alloy/Brass	X	O	O	O	O	O

This table is prepared in accordance with the provisions of SJ/T 11364.

O: Indicates that said hazardous substance contained in all of the homogeneous materials for this part is below the limit requirement of GB/T 26572.

X: Indicates that said hazardous substance contained in at least one of the homogeneous materials for this part is above the limit requirement of GB/T 26572.

Lead is present due to allowed exemption in Annex III or Annex IV of the European RoHS Directive 2011/65/EU.

## 1.0 INTRODUCTION

Series 134A20 Tourmaline Pressure Bar with In-Line Amplifier consists of a Series 134A Tourmaline Pressure Bar connected to a three-inch, low-noise cable that connects into Series 402 In-Line Source Follower Voltage Amplifier. See Figure 1.

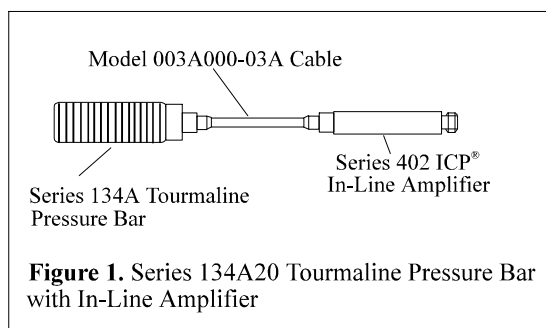

The Tourmaline Pressure Bars is a high-pressure, fast rise time, suppressed-resonance blast sensor ideal for single-shot, high-frequency measurements of incident or reflected shock wave pressures found in studies of plasma physics and hyper-sonics. Ranges up to 20,000 psi are available.

The Series 134A20 is typically powered by a PCB Series 480 ICP® Power Conditioner (constant current) or equivalent. Power and signal is conducted over a single-conductor coaxial cable with the shield serving as a signal return. Output from the power conditioner is usually fed into a high-speed readout instrument, such as a digital oscilloscope.

## 2.0 DESCRIPTION

The Series 134A20 Tourmaline Pressure Bar with In-Line Amplifier consists of three components attached together and calibrated as a system. The Series 134A Tourmaline Pressure Bar senses and transduces a pressure/shock wave into a high-impedance, electrostatic charge. This charge is sent through the three-inch, low-noise cable into the Series 402A In-Line Amplifier, where it is converted into a low-impedance voltage with less than 100 ohms output impedance. See Figure 2.

The circuit in the in-line amplifier consists of a MOSFET input IC with a very high transconductance, resulting in a voltage gain that is very close to unity. The source terminal "follows" the gate voltage instantaneously, without a shift in phase (i.e., the amplifier is non-inverting).

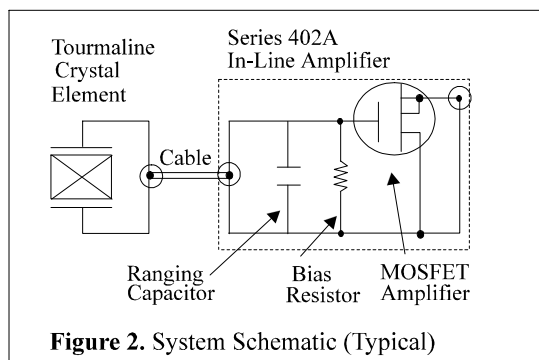

## 2.1 SYSTEM OUTPUT

The system output of Series 134A20 is a low-impedance output governed by the following equation:

$$V = \frac{Q}{C1 + C2 + C3}$$

where:

- V = voltage sensitivity of system (V/psi)
- Q = charge output of Tourmaline Bar (pC/psi), Model 134A
- C1 = capacitance of Tourmaline Bar (pF), Series 134A
- C2 = capacitance of three-inch cable (pF), Model 003A000-03
- C3 = capacitance of input of in-line amplifier (pF), Series 402A

A system calibration is supplied with Series 134A20 that shows the system output in mV/psi.

## 3.0 INSTALLATION

See the Installation Drawing included in the back of this manual for a description of the Tourmaline Bar and its installation. *Install in a gas medium where the measurement is to be taken. The sensor can not be normally used in a liquid medium.*

Connect the Series 134A20 Tourmaline Pressure Bar with In-Line Amplifier to a PCB power conditioner. Connect the output of the power conditioner to an appropriate readout instrument.

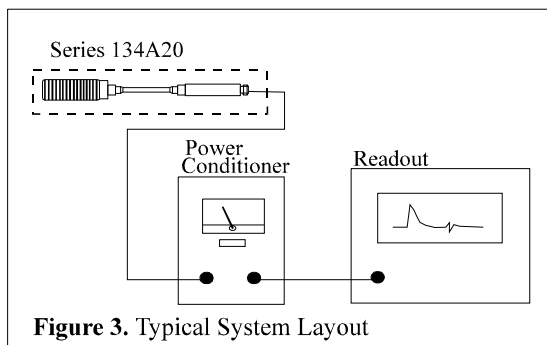

Figure 3. Typical System Layout

Tie the three-inch, low-noise cable to a rigid structure to prevent excessive motion and noise. Allow for strain relief.

**Caution**

If the tourmaline pressure bar or the three-inch cable become disconnected from the in-line amplifier, take caution to momentarily electrically short out the cable and tourmaline pressure bar before reconnecting the cable to the in-line amplifier. This prevents any unusual high charge buildup from damaging the input stage of the in-line amplifier.

Black vinyl tape is supplied on the sensing end of the tourmaline bar to dampen heat transfer into the sensing crystal. This tape can be removed and replaced if damaged.

**4.0 OPERATION**

Switch on the (PCB) power conditioner and observe the bias monitoring voltmeter (or LED) on the front panel.

If the indicator reads proper bias (green area on the meter, approximately 11 volts), the connections from the Series 402A In-Line Amplifier are correct and the in-line amplifier is operational. If the meter reads in the red or yellow areas, the system is shorted or open. The short or open circuit may be in the in-line amplifier, the cable connecting the in-line amplifier to the power conditioner, or in the power conditioner.

Allow the system to stabilize for a minute. A signal drift may occur when connecting the power conditioner to the readout instrument. This should stabilize as components in the power conditioner and readout instrument charge.

If long cables between the Series 134A20 and the power conditioner are used, impedance matching of the long cable and increase of the constant current in the power conditioner may be required because of the high-speed response of the sensor. Check with PCB if there are questions.

**5.0 CALIBRATION**

The tourmaline pressure bar must be calibrated *dynamically*. The tourmaline pressure bar does not measure static pressures. In addition, application of high static pressure to the tourmaline bar may cause damage.

Two methods are used at PCB to calibrate the Series 134A20: a shock tube and a hydraulic pulse tester. The shock tube is used primarily to check the sub-microsecond response of the tourmaline pressure bar.

The hydraulic pulse tester is used to generate a known, short-duration pressure pulse at five different pressure levels to determine the average sensitivity of the sensor.

Recalibration services are offered by PCB. In addition, the shock tube and hydraulic pulse calibrator are offered as standard products by PCB.

**6.0 USE OF CHARGE MODE TOURMALINE PRESSURE BAR**

The tourmaline pressure bar is a charge output piezoelectric sensor that can be used without the in-line source follower amplifier for certain applications. Calibration information is supplied showing (charge) output sensitivity of the tourmaline bar alone, along with its crystal capacitance.

Note that the Series 402A In-Line Amplifier features a frequency response of greater than 1 MHz. A charge amplifier used with the tourmaline pressure bar may limit the upper frequency response of the system.

Connecting the Series 134A Tourmaline Pressure Bar directly to a readout instrument without the use of the Series 402A In-Line Amplifier or other impedance-converting device can be done with some limitations. The input impedance of the readout instrument may be significantly low to create a very high-pass filtering effect. This can affect measurement of pulse duration or amplitude of a slow-rising pulse. Also, the voltage sensitivity of the output of the tourmaline bar into the readout instrument is affected by the cable capacitance and input capacitance of the readout instrument.

Contact the factory with any questions regarding use of the sensor in the charge output mode.

## **6.1 USE OF THE IN-LINE AMPLIFIER**

The Series 402A In-Line Amplifier is used to convert the high-impedance output of the tourmaline pressure bar into a low-impedance output. The in-line amplifier may also be used as a unity gain amplifier for checking system frequency response. A signal generator is connected to the input of the in-line amplifier and fed through the system.

## **7.0 MAINTENANCE AND REPAIR**

The electrical connectors on the tourmaline pressure bar, the input of the in-line amplifier, and the three-inch, low-noise cable must be kept clean and dry, especially if they are operating in a dusty or wet environment. This is to prevent drift due to low insulation resistance. Also, note the following precautions:

1. Do not exceed maximum levels.

2. Constant temperatures around the tourmaline bar should be limited to 150°F. Short-term exposure to higher temperatures, such as that found in a blast wave, do not cause damage.

3. Use only PCB power conditioners or approved alternative.

4. Current to the in-line amplifier must be limited to not more than 20 mA to avoid damage.

5. If the tourmaline pressure bar and in-line amplifier are to be left outside overnight or in humid or rainy environments, they should be coated with silicone oil and covered.





**Model 402A**

**IN-LINE AMPLIFIER**

**Installation and Operating Manual**

**For assistance with the operation of this product,  
contact PCB Piezotronics, Inc.**

**Toll-free: 800-828-8840  
24-hour SensorLine: 716-684-0001  
Fax: 716-684-0987  
E-mail: [info@pcb.com](mailto:info@pcb.com)  
Web: [www.pcb.com](http://www.pcb.com)**



## Repair and Maintenance

PCB guarantees Total Customer Satisfaction through its “Lifetime Warranty Plus” on all Platinum Stock Products sold by PCB and through its limited warranties on all other PCB Stock, Standard and Special products. Due to the sophisticated nature of our sensors and associated instrumentation, **field servicing and repair is not recommended and, if attempted, will void the factory warranty.**

Beyond routine calibration and battery replacements where applicable, our products require no user maintenance. Clean electrical connectors, housings, and mounting surfaces with solutions and techniques that will not harm the material of construction. Observe caution when using liquids near devices that are not hermetically sealed. Such devices should only be wiped with a dampened cloth—never saturated or submerged.

In the event that equipment becomes damaged or ceases to operate, our Application Engineers are here to support your troubleshooting efforts 24 hours a day, 7 days a week. Call or email with model and serial number as well as a brief description of the problem.

## Calibration

Routine calibration of sensors and associated instrumentation is necessary to maintain measurement accuracy. We recommend calibrating on an annual basis, after exposure to any extreme environmental influence, or prior to any critical test.

PCB Piezotronics is an ISO-9001 certified company whose calibration services are accredited by A2LA to ISO/IEC 17025, with full traceability to SI through N.I.S.T. In addition to our standard calibration services, we also offer specialized tests, including: sensitivity at elevated or cryogenic temperatures, phase response, extended high or low frequency response, extended range, leak testing, hydrostatic pressure testing, and others. For more information, contact your local PCB Piezotronics distributor, sales representative, or factory customer service representative.

## Returning Equipment

If factory repair is required, our representatives will provide you with a Return Material Authorization (RMA) number, which we use to reference any information you have already provided and expedite the repair process. This number should be clearly marked on the outside of all returned package(s) and on any packing list(s) accompanying the shipment.

## Contact Information

PCB Piezotronics, Inc.  
3425 Walden Ave.  
Depew, NY14043 USA  
Toll-free: (800) 828-8840  
24-hour SensorLine: (716) 684-0001  
General inquiries: [info@pcb.com](mailto:info@pcb.com)  
Repair inquiries: [rma@pcb.com](mailto:rma@pcb.com)

For a complete list of distributors, global offices and sales representatives, visit our website, [www.pcb.com](http://www.pcb.com).

## Safety Considerations

This product is intended for use by qualified personnel who recognize shock hazards and are familiar with the precautions required to avoid injury. While our equipment is designed with user safety in mind, the protection provided by the equipment may be impaired if equipment is used in a manner not specified by this manual.

Discontinue use and contact our 24-Hour Sensorline if:

- Assistance is needed to safely operate equipment
- Damage is visible or suspected
- Equipment fails or malfunctions

For complete equipment ratings, refer to the enclosed specification sheet for your product.

## Definition of Terms and Symbols

The following symbols may be used in this manual:



### **DANGER**

Indicates an immediate hazardous situation, which, if not avoided, may result in death or serious injury.

**CAUTION**

Refers to hazards that could damage the instrument.

**NOTE**

Indicates tips, recommendations and important information. The notes simplify processes and contain additional information on particular operating steps.

**The following symbols may be found on the equipment described in this manual:**



This symbol on the unit indicates that high voltage may be present. Use standard safety precautions to avoid personal contact with this voltage.



This symbol on the unit indicates that the user should refer to the operating instructions located in the manual.



This symbol indicates safety, earth ground.



PCB工业监视和测量设备 - 中国RoHS2公布表

PCB Industrial Monitoring and Measuring Equipment - China RoHS 2 Disclosure Table

部件名称	有害物质					
	铅 (Pb)	汞 (Hg)	镉 (Cd)	六价铬 (Cr(VI))	多溴联苯 (PBB)	多溴二苯醚 (PBDE)
住房	0	0	0	0	0	0
PCB板	X	0	0	0	0	0
电气连接器	0	0	0	0	0	0
压电晶体	X	0	0	0	0	0
环氧	0	0	0	0	0	0
铁氟龙	0	0	0	0	0	0
电子	0	0	0	0	0	0
厚膜基板	0	0	X	0	0	0
电线	0	0	0	0	0	0
电缆	X	0	0	0	0	0
塑料	0	0	0	0	0	0
焊接	X	0	0	0	0	0
铜合金/黄铜	X	0	0	0	0	0
本表格依据 SJ/T 11364 的规定编制。						
0：表示该有害物质在该部件所有均质材料中的含量均在 GB/T 26572 规定的限量要求以下。						
X：表示该有害物质至少在该部件的某一均质材料中的含量超出 GB/T 26572 规定的限量要求。						
铅是欧洲RoHS指令2011/65/ EU附件三和附件四目前由于允许的豁免。						

CHINA RoHS COMPLIANCE

Component Name	Hazardous Substances					
	Lead (Pb)	Mercury (Hg)	Cadmium (Cd)	Chromium VI Compounds (Cr(VI))	Polybrominated Biphenyls (PBB)	Polybrominated Diphenyl Ethers (PBDE)
Housing	O	O	O	O	O	O
PCB Board	X	O	O	O	O	O
Electrical Connectors	O	O	O	O	O	O
Piezoelectric Crystals	X	O	O	O	O	O
Epoxy	O	O	O	O	O	O
Teflon	O	O	O	O	O	O
Electronics	O	O	O	O	O	O
Thick Film Substrate	O	O	X	O	O	O
Wires	O	O	O	O	O	O
Cables	X	O	O	O	O	O
Plastic	O	O	O	O	O	O
Solder	X	O	O	O	O	O
Copper Alloy/Brass	X	O	O	O	O	O

This table is prepared in accordance with the provisions of SJ/T 11364.

O: Indicates that said hazardous substance contained in all of the homogeneous materials for this part is below the limit requirement of GB/T 26572.

X: Indicates that said hazardous substance contained in at least one of the homogeneous materials for this part is above the limit requirement of GB/T 26572.

Lead is present due to allowed exemption in Annex III or Annex IV of the European RoHS Directive 2011/65/EU.

OPERATING GUIDE  
 SERIES 401A & 402A  
 ICP SOURCE FOLLOWER AMPLIFIERS

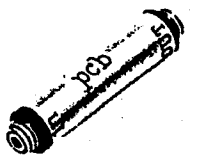

CONNECTOR TYPE  
401A Voltage-Follower

IN-LINE TYPE  
402A Voltage-Follower

**1.0 INTRODUCTION**

The series 401A and 402A are miniature, unity gain, impedance converting voltage amplifiers which operate from constant current power units in a 2-wire mode.

These epoxy potted amplifiers are designed to convert the high impedance voltage from piezoelectric transducers to a low impedance voltage able to drive most readout instruments directly.

The input impedance of these amplifiers is extremely high ( $10^9$  &  $10^{11}$  ohms) while the output impedance is less than 100 ohms.

Except for mechanical configuration, the 401A series is identical to the 402A series.

See Guide G-0001 for a complete coverage of the ICP (Integrated Circuit Piezoelectric) concept.

**2.0 DESCRIPTION**

The series 401A is the "connector" series, i.e. it is designed to attach directly to the 10-32 co-axial connector of piezoelectric transducers as shown in Figure 1.

When used as in Figure 1, the piezoelectric transducer is converted to ICP operation.

The series 402A "in-line" series is designed to be used in a co-axial line as shown in Figure 2.

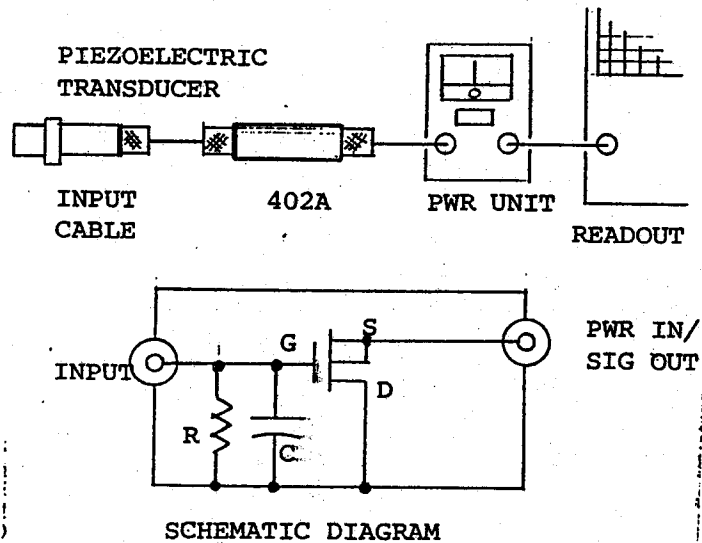

Figure 2  
Typical Application  
Series 402A

The series 402A is useful in field applications where high temperature or other severe environmental factors precludes the use of transducers with built-in amplifiers.

**2.1 THEORY OF OPERATION**

These impedance converting amplifiers utilize a MOSFET input integrated circuit as shown in Figures 1 & 2.

The circuit consists of a MOSFET input IC with a very high transconductance ( $g_m$ ) resulting in a voltage gain of very close to unity. The source terminal "follows" the gate voltage instantaneously and without a shift in phase, i.e. the amplifiers are non-inverting.

The input resistor, R serves 2 functions.

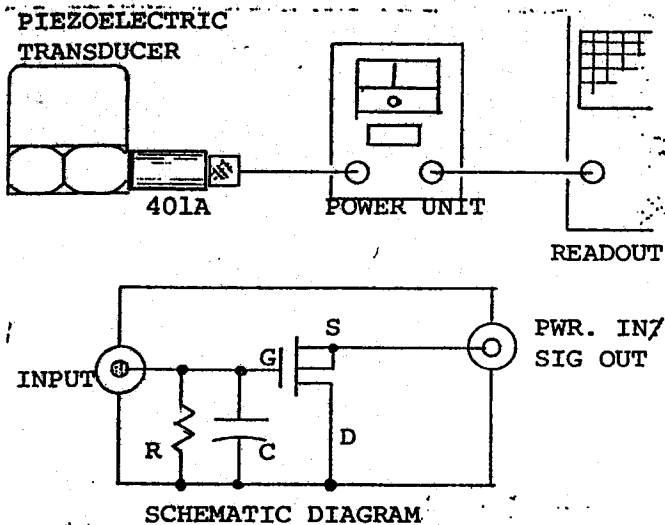

Figure 1  
Typical Application  
Series 401A

It biases the gate at drain potential for proper operation of the IC device and : it drains off spurious long term charge that exists at the input terminal from thermal effects on crystal transducer elements.

Because of the lowered insulation resistance of ceramic and non-quartz crystal transducers, this input resistance should be  $10^9$  ohms when used with such transducers. Consult our data sheets for the appropriate model numbers. (See section 7.0)

Quartz transducers on the other hand, have very high internal resistance and low capacitance, thus, the  $10^{11}$  value of input resistance should be used for this type of transducer.

In both models, the outer case is at electrical ground potential.

## 2.2 INPUT DISCHARGE TIME CONSTANT

The input time constant is dependent upon two parameters, 1) the input resistor value  
2) the total input capacitance.

The input capacitance value is the sum of all capacitance across the input connector, including transducer capacitance, cable capacitance (if used) and input ranging capacitor (C).

The input resistance is either  $10^9$  ohm or  $10^{11}$  ohms depending upon exact model ordered.

To calculate the resultant discharge time constant (Sec), simply multiply the input resistor value (ohms) by the total shunt capacitance (farads).

Refer to Guide G0001 for effect of discharge TC on low frequency response.

## 2.3 RANGING

The voltage sensitivity of the transduction system varies inversely with the total input shunt capacitance and directly with the transducer charge sensitivity as follows:

$$V = \frac{Q}{C_t} \quad (\text{Eq. 1})$$

where:

Q = charge sensitivity of transducer in pC/mech. unit.

$C_t$  = Total shunt capacitance in pF.

V = Voltage sensitivity in volts/mech. unit.

To obtain rough value of system sensitivity, simply divide the transducer charge sensitivity by total capacitance at the amplifier input as shown in Eq. 1.

Note: Don't forget to include input cable capacitance when using the series 402A.

To increase the range of a transducer i.e. to decrease system voltage sensitivity, select a 401A or 402A with larger value of input capacitor. 3 values are available; 10, 100 and 1000 pf.

Final system sensitivity should always be determined by calibration with known inputs.

## 3.0 INSTALLATION

The Model 401A is simply threaded directly on to the 10-32 coaxial connector of most transducers.

To exclude moisture from this high impedance input connection, protect joint with shrink tubing, RTV rubber coating or other suitable means.

Connect the power/signal connector to an ICP Power Unit such as the Model 480B, 482A, 484B, 483A etc. Using co-axial cable or solder connector adaptors (Model 070A09) and ordinary 2-wire cable.

In vibratory environments, clamp 402A to surface to prevent damage due to excessive shock motion. A plastic clamp is provided for this purpose.

Connect the power/signal connector to power unit as previously described for Model 401A.

Caution: Before connecting inputs to both models, short out cable and/or transducer to dissipate any accumulated charges.

## 4.0 OPERATION

Operation of these amplifiers is very similar to operation of ICP transducers.

All PCB Power Units have fault monitor meters on the front panel to monitor operation of the built-in amplifiers in ICP transducers. Since the Models 401A and 402A utilize the identical circuit as ICP transducers, use of the fault monitor meter is similar.

A mid-scale reading on the meter (green area) indicates proper bias level for the amplifier.

A zero reading (red area) indicates a shorted condition in the built-in amplifier or in the cable connecting amplifier to power unit.

A full scale reading (yellow area) indicates an open circuit condition in amplifier or interconnecting cable.

## 5.0 FREQUENCY RESPONSE

The low frequency response of these amplifiers when used with piezoelectric transducers is dependent upon the discharge time constant (or coupling time constant of power unit, if shorter than the discharge TC) in accordance with the following relationship:

$$f_0 = \frac{.16}{RC} \quad (\text{Eq 2})$$

where:

$f_0$  = -3db low freq. cut-off, (Hz)

RC = input discharge TC

See section 6.1.1 of Guide G-0001 for a more thorough discussion of this topic.

The high frequency response of these amplifiers, for small signals and driving short cables is better than 1 megahertz.

For optimum frequency response when driving long cables at maximum output voltages, use maximum allowable input current (20mA).

Many PCB Power Units such as 482A & 484B have adjustable output current to facilitate driving long lines at high voltage levels.

In most cases, high frequency response in actual use will be limited by transducer parameters.

## 6.0 MAINTENANCE:

The miniature size and epoxy encapsulation precludes most maintenance. Should input connectors become dirty, reducing input time constant, clean with lint free wipes dipped in freon TF (R) or other suitable solvent. Avoid solvent containing ketones.

**Caution:** Avoid touching the input terminal directly with the fingers since accumulated static charge can destroy the input MOSFET.

After wiping input connector, dry in oven at 200°F for several hours. Do not heat beyond +250°F.

## 7.0 CAUTION - HIGH OUTPUT, THERMALLY SENSITIVE TRANSDUCERS

Certain ceramic transducers are capable of generating huge quantities of charge (and voltage) when affected by relatively small thermal transients such as when picked up by hand.

In recent tests at PCB, a ceramic accelerometer, when picked up and held in the hand produced over 100,000 pC of charge resulting in over 100 volts into a high impedance load, over a period of several seconds.

High voltages like this can destroy the input mosfet in the 401A and 402A if not drained away fast enough.

For transducers such as these, it may be necessary to reduce the input resistor below  $1 \times 10^9$  ohms ( $1 \times 10^8$  or  $1 \times 10^7$ ) to rapidly dissipate such spurious outputs. Generally, internal capacitances of these types of transducers are extremely high ( $> 1000$  pF) resulting in adequate low frequency response, even with the low value input resistance. Consult factory if it is decided this problem exists in your installation.

MANUAL NUMBER: 1842C  
MANUAL REVISION: NR



Model Number

402A

## IN-LINE AMPLIFIER

Revision: F

ECN #: 30186

**Performance**

	<u>ENGLISH</u>	<u>SI</u>	
Input Range	± 5.0 V	± 5.0 V	[2]
Overrange	± 10 V	± 10 V	
Output Range(AC)	± 5.0 V	± 5.0 V	
Voltage Gain(± 2 %)(non-inverting)	0.98	0.98	
Low Frequency Cutoff	0.5 Hz	0.5 Hz	[3]
High Frequency Response	1000 kHz	1000 kHz	[4]

**Environmental**

Temperature Range(Operating)	-65 to +250 °F	-54 to +121 °C	
Maximum Shock	5000 g pk	49,050 m/s <sup>2</sup> pk	
Maximum Vibration(5 to 2000 Hz)	1000 g pk	9810 m/s <sup>2</sup> pk	

**Electrical**

Excitation Voltage	18 to 28 VDC	18 to 28 VDC	
Constant Current Excitation	2 to 20 mA	2 to 20 mA	
Output Bias Voltage	8 to 14 VDC	8 to 14 VDC	
Input Resistance(± 20 %)	10 <sup>11</sup> ohm	10 <sup>11</sup> ohm	
Input Capacitance	<8 pF	<8 pF	
Maximum Input Voltage(without damage)	100 V	100 V	
Discharge Time Constant(± 30 %)	1.0 sec	1.0 sec	[1]
Output Impedance	<100 ohm	<100 ohm	
Broadband Electrical Noise(1 to 10 kHz)	43.0 µV	43.0 µV	

**Physical**

Housing Material	Stainless Steel	Stainless Steel	
Sealing	Welded Hermetic	Welded Hermetic	
Electrical Connector(Input)	10-32 Coaxial Jack	10-32 Coaxial Jack	
Electrical Connector(Output)	10-32 Coaxial Jack	10-32 Coaxial Jack	
Size (Diameter x Length)	0.25 in x 1.17 in	6.4 mm x 29.7 mm	
Weight	0.132 oz	3.75 gm	



[5]

All specifications are at room temperature unless otherwise specified.  
In the interest of constant product improvement, we reserve the right to change specifications without notice.

ICP® is a registered trademark of PCB Group, Inc.

**OPTIONAL VERSIONS**

Optional versions have identical specifications and accessories as listed for the standard model except where noted below. More than one option may be used.

**NOTES:**

- [1] Actual Discharge Time Constant is the product between the Input Resistance and the Total Input Capacitance (including cable capacitance and sensor capacitance).  
[2] For +10 volt output, minimum 24 VDC supply voltage required. Negative 10 volt output may be limited by output bias.  
[3] Actual Low Frequency Cutoff is approximately 0.5 + Actual Discharge Time Constant.  
[4] High frequency response may be limited by supply current and output cable length.  
[5] See PCB Declaration of Conformance PS024 for details.

Entered: BLS	Engineer: RF	Sales: RWM	Approved: EPB	Spec Number:
Date: 2/27/09	Date: 2/27/09	Date: 2/27/09	Date: 2/27/09	402-1010-80

**PCB PIEZOTRONICS™**  
PRESSURE DIVISION  
3425 Walden Avenue, Depew, NY 14043

Phone: 716-684-0001  
Fax: 716-686-9129  
E-Mail: pressure@pcb.com



## **Model 134A24**

**Tourmaline ICP® pressure bar with 003 cable and inline source follower, 1000 psi, 5 mV/psi, 0.2 microsecond rise time**

### **Installation and Operating Manual**

**This manual contains the 134-1010-01, 402A installation and operating manuals that comprise a Model 134A24 Tourmaline ICP® pressure bar with 003 cable and inline source follower, 1000 psi, 5 mV/psi, 0.2 microsecond rise time kit.**

**For assistance with the operation of this product,  
contact the PCB Piezotronics, Inc.**

**Toll-free: 716-684-0001  
24-hour SensorLine: 716-684-0001  
Fax: 716-684-0987  
E-mail: [info@pcb.com](mailto:info@pcb.com)  
Web: [www.pcb.com](http://www.pcb.com)**



## Repair and Maintenance

PCB guarantees Total Customer Satisfaction through its “Lifetime Warranty Plus” on all Platinum Stock Products sold by PCB and through its limited warranties on all other PCB Stock, Standard and Special products. Due to the sophisticated nature of our sensors and associated instrumentation, **field servicing and repair is not recommended and, if attempted, will void the factory warranty.**

Beyond routine calibration and battery replacements where applicable, our products require no user maintenance. Clean electrical connectors, housings, and mounting surfaces with solutions and techniques that will not harm the material of construction. Observe caution when using liquids near devices that are not hermetically sealed. Such devices should only be wiped with a dampened cloth—never saturated or submerged.

In the event that equipment becomes damaged or ceases to operate, our Application Engineers are here to support your troubleshooting efforts 24 hours a day, 7 days a week. Call or email with model and serial number as well as a brief description of the problem.

## Calibration

Routine calibration of sensors and associated instrumentation is necessary to maintain measurement accuracy. We recommend calibrating on an annual basis, after exposure to any extreme environmental influence, or prior to any critical test.

PCB Piezotronics is an ISO-9001 certified company whose calibration services are accredited by A2LA to ISO/IEC 17025, with full traceability to SI through N.I.S.T. In addition to our standard calibration services, we also offer specialized tests, including: sensitivity at elevated or cryogenic temperatures, phase response, extended high or low frequency response, extended range, leak testing, hydrostatic pressure testing, and others. For more information, contact your local PCB Piezotronics distributor, sales representative, or factory customer service representative.

## Returning Equipment

If factory repair is required, our representatives will provide you with a Return Material Authorization (RMA) number, which we use to reference any information you have already provided and expedite the repair process. This number should be clearly marked on the outside of all returned package(s) and on any packing list(s) accompanying the shipment.

## Contact Information

PCB Piezotronics, Inc.  
3425 Walden Ave.  
Depew, NY14043 USA  
Toll-free: (800) 828-8840  
24-hour SensorLine: (716) 684-0001  
General inquiries: [info@pcb.com](mailto:info@pcb.com)  
Repair inquiries: [rma@pcb.com](mailto:rma@pcb.com)

For a complete list of distributors, global offices and sales representatives, visit our website, [www.pcb.com](http://www.pcb.com).

## Safety Considerations

This product is intended for use by qualified personnel who recognize shock hazards and are familiar with the precautions required to avoid injury. While our equipment is designed with user safety in mind, the protection provided by the equipment may be impaired if equipment is used in a manner not specified by this manual.

Discontinue use and contact our 24-Hour Sensorline if:

- Assistance is needed to safely operate equipment
- Damage is visible or suspected
- Equipment fails or malfunctions

For complete equipment ratings, refer to the enclosed specification sheet for your product.

## Definition of Terms and Symbols

The following symbols may be used in this manual:



### DANGER

Indicates an immediate hazardous situation, which, if not avoided, may result in death or serious injury.

**CAUTION**

Refers to hazards that could damage the instrument.

**NOTE**

Indicates tips, recommendations and important information. The notes simplify processes and contain additional information on particular operating steps.

**The following symbols may be found on the equipment described in this manual:**



This symbol on the unit indicates that high voltage may be present. Use standard safety precautions to avoid personal contact with this voltage.



This symbol on the unit indicates that the user should refer to the operating instructions located in the manual.



This symbol indicates safety, earth ground.



PCB工业监视和测量设备 - 中国RoHS2公布表

PCB Industrial Monitoring and Measuring Equipment - China RoHS 2 Disclosure Table

部件名称	有害物质					
	铅 (Pb)	汞 (Hg)	镉 (Cd)	六价铬 (Cr(VI))	多溴联苯 (PBB)	多溴二苯醚 (PBDE)
住房	0	0	0	0	0	0
PCB板	X	0	0	0	0	0
电气连接器	0	0	0	0	0	0
压电晶体	X	0	0	0	0	0
环氧	0	0	0	0	0	0
铁氟龙	0	0	0	0	0	0
电子	0	0	0	0	0	0
厚膜基板	0	0	X	0	0	0
电线	0	0	0	0	0	0
电缆	X	0	0	0	0	0
塑料	0	0	0	0	0	0
焊接	X	0	0	0	0	0
铜合金/黄铜	X	0	0	0	0	0
本表格依据 SJ/T 11364 的规定编制。						
0：表示该有害物质在该部件所有均质材料中的含量均在 GB/T 26572 规定的限量要求以下。						
X：表示该有害物质至少在该部件的某一均质材料中的含量超出 GB/T 26572 规定的限量要求。						
铅是欧洲RoHS指令2011/65/ EU附件三和附件四目前由于允许的豁免。						

CHINA RoHS COMPLIANCE

Component Name	Hazardous Substances					
	Lead (Pb)	Mercury (Hg)	Cadmium (Cd)	Chromium VI Compounds (Cr(VI))	Polybrominated Biphenyls (PBB)	Polybrominated Diphenyl Ethers (PBDE)
Housing	O	O	O	O	O	O
PCB Board	X	O	O	O	O	O
Electrical Connectors	O	O	O	O	O	O
Piezoelectric Crystals	X	O	O	O	O	O
Epoxy	O	O	O	O	O	O
Teflon	O	O	O	O	O	O
Electronics	O	O	O	O	O	O
Thick Film Substrate	O	O	X	O	O	O
Wires	O	O	O	O	O	O
Cables	X	O	O	O	O	O
Plastic	O	O	O	O	O	O
Solder	X	O	O	O	O	O
Copper Alloy/Brass	X	O	O	O	O	O

This table is prepared in accordance with the provisions of SJ/T 11364.

O: Indicates that said hazardous substance contained in all of the homogeneous materials for this part is below the limit requirement of GB/T 26572.

X: Indicates that said hazardous substance contained in at least one of the homogeneous materials for this part is above the limit requirement of GB/T 26572.

Lead is present due to allowed exemption in Annex III or Annex IV of the European RoHS Directive 2011/65/EU.

Performance	ENGLISH	SI	
Measurement Range(for ±5V output)	1,000 psi	6,895 kPa	
Useful Overrange(for ± 10V output)	2,000 psi	13,790 kPa	[1]
Sensitivity(± 15 %)	5 mV/psi	0.73 mV/kPa	[2]
Maximum Pressure	15,000 psi	103,425 kPa	
Resolution	0.02 psi	0.14 kPa	[3]
Resonant Frequency	≥ 1,500 kHz	≥ 1,500 kHz	
Rise Time(Reflected)	≤ 0.2 μ sec	≤ 0.2 μ sec	
Low Frequency Response(- 5 %)	0.25 Hz	0.25 Hz	
Non-Linearity	≤ 2 % FS	≤ 2 % FS	[4]
<b>Environmental</b>			
Temperature Range(Operating)	-32 to +120 °F	-36 to +49 °C	
Maximum Flash Temperature	5,000 °F	2,760 °C	
<b>Electrical</b>			
Output Polarity(Positive Pressure)	Positive	Positive	
Discharge Time Constant(at room temp)	≥ 1 sec	≥ 1 sec	
Excitation Voltage	20 to 30 VDC	20 to 30 VDC	
Constant Current Excitation	2 to 20 mA	2 to 20 mA	
Output Impedance	≤ 100 Ohm	≤ 100 Ohm	
Output Bias Voltage	8 to 14 VDC	8 to 14 VDC	
<b>Physical</b>			
Sensing Element	Tourmaline	Tourmaline	
Housing Material	Stainless Steel	Stainless Steel	
Diaphragm	Epoxy	Epoxy	
Sealing	Epoxy	Epoxy	
Electrical Connector	10-32 Coaxial Jack	10-32 Coaxial Jack	
Weight	1.4 oz	39 gm	

**OPTIONAL VERSIONS**

Optional versions have identical specifications and accessories as listed for the standard model except where noted below. More than one option may be used.

**M** - Metric Mount

**NOTES:**

[1]For +10 volt output, minimum 24 VDC supply voltage required. Negative 10 volt output may be limited by output bias.

[2]Calibrated as a system using (3 inch) type 003 cable and 402A series in-line amplifier.

[3]Typical.

[4]Zero-based, least-squares, straight line method.

[5]See PCB Declaration of Conformance PS023 for details.

**SUPPLIED ACCESSORIES:**

Model 061A30 Spanner Wrench, 2 Pin (1)

Model PCS-6AB Calibration of dynamic pressure sensors at 100% and 10% of sensor range.

Entered: ND	Engineer: RPF	Sales: MV	Approved: RPF	Spec Number:
Date: 12/11/2024	Date: 12/11/2024	Date: 12/11/2024	Date: 12/11/2024	6616



All specifications are at room temperature unless otherwise specified.  
 In the interest of constant product improvement, we reserve the right to change specifications without notice.  
 ICP® is a registered trademark of PCB Piezotronics, Inc.

**PCB PIEZOTRONICS**  
AN AMPHENOL COMPANY

Phone: 716-684-0001  
 Fax: 716-684-0987  
 E-Mail: info@pcb.com

3425 Walden Avenue, Depew, NY 14043



**Model 402A**  
**IN-LINE AMPLIFIER**  
**Installation and Operating Manual**

**For assistance with the operation of this product,  
contact PCB Piezotronics, Inc.**

**Toll-free: 800-828-8840**  
**24-hour SensorLine: 716-684-0001**  
**Fax: 716-684-0987**  
**E-mail: [info@pcb.com](mailto:info@pcb.com)**  
**Web: [www.pcb.com](http://www.pcb.com)**





## Repair and Maintenance

PCB guarantees Total Customer Satisfaction through its “Lifetime Warranty Plus” on all Platinum Stock Products sold by PCB and through its limited warranties on all other PCB Stock, Standard and Special products. Due to the sophisticated nature of our sensors and associated instrumentation, **field servicing and repair is not recommended and, if attempted, will void the factory warranty.**

Beyond routine calibration and battery replacements where applicable, our products require no user maintenance. Clean electrical connectors, housings, and mounting surfaces with solutions and techniques that will not harm the material of construction. Observe caution when using liquids near devices that are not hermetically sealed. Such devices should only be wiped with a dampened cloth—never saturated or submerged.

In the event that equipment becomes damaged or ceases to operate, our Application Engineers are here to support your troubleshooting efforts 24 hours a day, 7 days a week. Call or email with model and serial number as well as a brief description of the problem.

## Calibration

Routine calibration of sensors and associated instrumentation is necessary to maintain measurement accuracy. We recommend calibrating on an annual basis, after exposure to any extreme environmental influence, or prior to any critical test.

PCB Piezotronics is an ISO-9001 certified company whose calibration services are accredited by A2LA to ISO/IEC 17025, with full traceability to SI through N.I.S.T. In addition to our standard calibration services, we also offer specialized tests, including: sensitivity at elevated or cryogenic temperatures, phase response, extended high or low frequency response, extended range, leak testing, hydrostatic pressure testing, and others. For more information, contact your local PCB Piezotronics distributor, sales representative, or factory customer service representative.

## Returning Equipment

If factory repair is required, our representatives will provide you with a Return Material Authorization (RMA) number, which we use to reference any information you have already provided and expedite the repair process. This number should be clearly marked on the outside of all returned package(s) and on any packing list(s) accompanying the shipment.

## Contact Information

PCB Piezotronics, Inc.  
3425 Walden Ave.  
Depew, NY14043 USA  
Toll-free: (800) 828-8840  
24-hour SensorLine: (716) 684-0001  
General inquiries: [info@pcb.com](mailto:info@pcb.com)  
Repair inquiries: [rma@pcb.com](mailto:rma@pcb.com)

For a complete list of distributors, global offices and sales representatives, visit our website, [www.pcb.com](http://www.pcb.com).

## Safety Considerations

This product is intended for use by qualified personnel who recognize shock hazards and are familiar with the precautions required to avoid injury. While our equipment is designed with user safety in mind, the protection provided by the equipment may be impaired if equipment is used in a manner not specified by this manual.

Discontinue use and contact our 24-Hour Sensorline if:

- Assistance is needed to safely operate equipment
- Damage is visible or suspected
- Equipment fails or malfunctions

For complete equipment ratings, refer to the enclosed specification sheet for your product.

## Definition of Terms and Symbols

The following symbols may be used in this manual:



### **DANGER**

Indicates an immediate hazardous situation, which, if not avoided, may result in death or serious injury.

**CAUTION**

Refers to hazards that could damage the instrument.

**NOTE**

Indicates tips, recommendations and important information. The notes simplify processes and contain additional information on particular operating steps.

**The following symbols may be found on the equipment described in this manual:**



This symbol on the unit indicates that high voltage may be present. Use standard safety precautions to avoid personal contact with this voltage.



This symbol on the unit indicates that the user should refer to the operating instructions located in the manual.



This symbol indicates safety, earth ground.



PCB工业监视和测量设备 - 中国RoHS2公布表

PCB Industrial Monitoring and Measuring Equipment - China RoHS 2 Disclosure Table

部件名称	有害物质					
	铅 (Pb)	汞 (Hg)	镉 (Cd)	六价铬 (Cr(VI))	多溴联苯 (PBB)	多溴二苯醚 (PBDE)
住房	0	0	0	0	0	0
PCB板	X	0	0	0	0	0
电气连接器	0	0	0	0	0	0
压电晶体	X	0	0	0	0	0
环氧	0	0	0	0	0	0
铁氟龙	0	0	0	0	0	0
电子	0	0	0	0	0	0
厚膜基板	0	0	X	0	0	0
电线	0	0	0	0	0	0
电缆	X	0	0	0	0	0
塑料	0	0	0	0	0	0
焊接	X	0	0	0	0	0
铜合金/黄铜	X	0	0	0	0	0
本表格依据 SJ/T 11364 的规定编制。						
0：表示该有害物质在该部件所有均质材料中的含量均在 GB/T 26572 规定的限量要求以下。						
X：表示该有害物质至少在该部件的某一均质材料中的含量超出 GB/T 26572 规定的限量要求。						
铅是欧洲RoHS指令2011/65/ EU附件三和附件四目前由于允许的豁免。						

CHINA RoHS COMPLIANCE

Component Name	Hazardous Substances					
	Lead (Pb)	Mercury (Hg)	Cadmium (Cd)	Chromium VI Compounds (Cr(VI))	Polybrominated Biphenyls (PBB)	Polybrominated Diphenyl Ethers (PBDE)
Housing	O	O	O	O	O	O
PCB Board	X	O	O	O	O	O
Electrical Connectors	O	O	O	O	O	O
Piezoelectric Crystals	X	O	O	O	O	O
Epoxy	O	O	O	O	O	O
Teflon	O	O	O	O	O	O
Electronics	O	O	O	O	O	O
Thick Film Substrate	O	O	X	O	O	O
Wires	O	O	O	O	O	O
Cables	X	O	O	O	O	O
Plastic	O	O	O	O	O	O
Solder	X	O	O	O	O	O
Copper Alloy/Brass	X	O	O	O	O	O

This table is prepared in accordance with the provisions of SJ/T 11364.

O: Indicates that said hazardous substance contained in all of the homogeneous materials for this part is below the limit requirement of GB/T 26572.

X: Indicates that said hazardous substance contained in at least one of the homogeneous materials for this part is above the limit requirement of GB/T 26572.

Lead is present due to allowed exemption in Annex III or Annex IV of the European RoHS Directive 2011/65/EU.

402-1010-90

PCB Piezotronics Inc. claims proprietary rights in the information disclosed hereon. Neither it nor any reproduction thereof will be disclosed to others without written consent of PCB Piezotronics Inc.

APPLICATION

NEXT ASS'Y	USED ON	VAR

REVISIONS

REV	DESCRIPTION	ECN	DATE	APP'D
E	REVISED PER ECN	12019	6/16/00	DM6/02

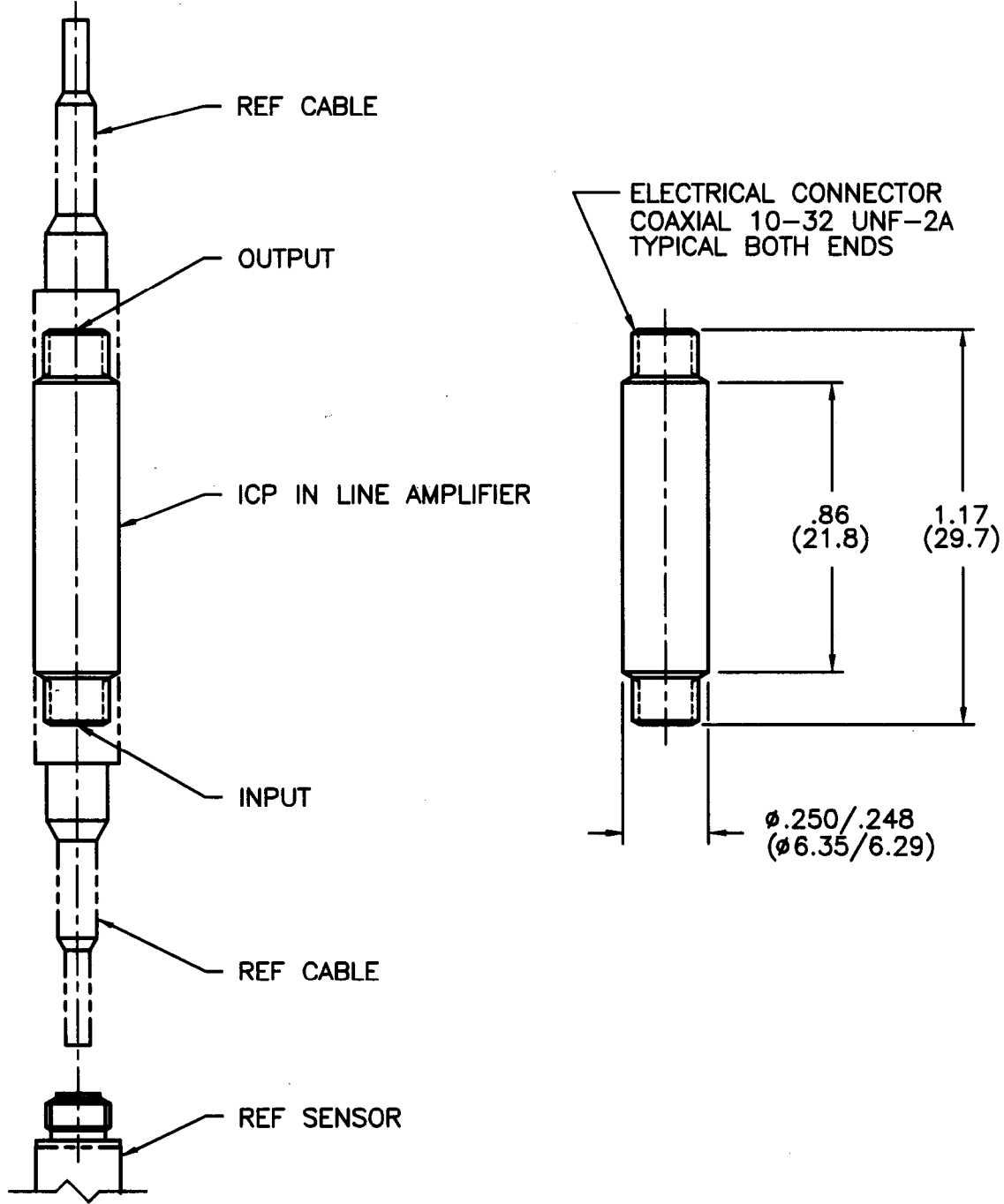

UNLESS SPECIFIED TOLERANCES

DIMENSIONS IN INCHES	DIMENSIONS IN MILLIMETERS (IN PARENTHESIS)
DECIMALS XX ± .01	DECIMALS XX ± 0.3
XXX ± .005	XXX ± 0.13
ANGLES ± 2 DEGREES	ANGLES ± 2 DEGREES
FILLETS AND RADII .003 - .005	FILLETS AND RADII (0.07 - 0.13)

DRAWN	MOP	6/14/00	MFG	TBS	6/20/00
CHK'D	DM	6/20/00	ENGR	RF	6/23/00
APP'D	RSV	7/13/00	SMO	RRR	7/13/00

**PCB PIEZOTRONICS**  
 3425 WALDEN AVE. DEPEW, NY 14043  
 (716) 684-0001 EMAIL: SALES@PCB.COM

CODE IDENT. NO. 52681

DWG. NO. 402-1010-90

SCALE: 2X SHEET 1 OF 1

TITLE  
 INSTALLATION DRAWING  
 MODEL SERIES 402A ICP  
 IN LINE AMPLIFIER



## **Model 134A24**

**Tourmaline ICP® pressure bar with 003 cable and inline source follower, 1000 psi, 5 mV/psi, 0.2 microsecond rise time**

### **Installation and Operating Manual**

**This manual contains the 134-1010-01, 402A installation and operating manuals that comprise a Model 134A24 Tourmaline ICP® pressure bar with 003 cable and inline source follower, 1000 psi, 5 mV/psi, 0.2 microsecond rise time kit.**

**For assistance with the operation of this product,  
contact the PCB Piezotronics, Inc.**

**Toll-free: 716-684-0001  
24-hour SensorLine: 716-684-0001  
Fax: 716-684-0987  
E-mail: [info@pcb.com](mailto:info@pcb.com)  
Web: [www.pcb.com](http://www.pcb.com)**



## Repair and Maintenance

PCB guarantees Total Customer Satisfaction through its “Lifetime Warranty Plus” on all Platinum Stock Products sold by PCB and through its limited warranties on all other PCB Stock, Standard and Special products. Due to the sophisticated nature of our sensors and associated instrumentation, **field servicing and repair is not recommended and, if attempted, will void the factory warranty.**

Beyond routine calibration and battery replacements where applicable, our products require no user maintenance. Clean electrical connectors, housings, and mounting surfaces with solutions and techniques that will not harm the material of construction. Observe caution when using liquids near devices that are not hermetically sealed. Such devices should only be wiped with a dampened cloth—never saturated or submerged.

In the event that equipment becomes damaged or ceases to operate, our Application Engineers are here to support your troubleshooting efforts 24 hours a day, 7 days a week. Call or email with model and serial number as well as a brief description of the problem.

## Calibration

Routine calibration of sensors and associated instrumentation is necessary to maintain measurement accuracy. We recommend calibrating on an annual basis, after exposure to any extreme environmental influence, or prior to any critical test.

PCB Piezotronics is an ISO-9001 certified company whose calibration services are accredited by A2LA to ISO/IEC 17025, with full traceability to SI through N.I.S.T. In addition to our standard calibration services, we also offer specialized tests, including: sensitivity at elevated or cryogenic temperatures, phase response, extended high or low frequency response, extended range, leak testing, hydrostatic pressure testing, and others. For more information, contact your local PCB Piezotronics distributor, sales representative, or factory customer service representative.

## Returning Equipment

If factory repair is required, our representatives will provide you with a Return Material Authorization (RMA) number, which we use to reference any information you have already provided and expedite the repair process. This number should be clearly marked on the outside of all returned package(s) and on any packing list(s) accompanying the shipment.

## Contact Information

PCB Piezotronics, Inc.  
3425 Walden Ave.  
Depew, NY14043 USA  
Toll-free: (800) 828-8840  
24-hour SensorLine: (716) 684-0001  
General inquiries: [info@pcb.com](mailto:info@pcb.com)  
Repair inquiries: [rma@pcb.com](mailto:rma@pcb.com)

For a complete list of distributors, global offices and sales representatives, visit our website, [www.pcb.com](http://www.pcb.com).

## Safety Considerations

This product is intended for use by qualified personnel who recognize shock hazards and are familiar with the precautions required to avoid injury. While our equipment is designed with user safety in mind, the protection provided by the equipment may be impaired if equipment is used in a manner not specified by this manual.

Discontinue use and contact our 24-Hour Sensorline if:

- Assistance is needed to safely operate equipment
- Damage is visible or suspected
- Equipment fails or malfunctions

For complete equipment ratings, refer to the enclosed specification sheet for your product.

## Definition of Terms and Symbols

The following symbols may be used in this manual:



### DANGER

Indicates an immediate hazardous situation, which, if not avoided, may result in death or serious injury.

**CAUTION**

Refers to hazards that could damage the instrument.

**NOTE**

Indicates tips, recommendations and important information. The notes simplify processes and contain additional information on particular operating steps.

**The following symbols may be found on the equipment described in this manual:**



This symbol on the unit indicates that high voltage may be present. Use standard safety precautions to avoid personal contact with this voltage.



This symbol on the unit indicates that the user should refer to the operating instructions located in the manual.



This symbol indicates safety, earth ground.





PCB工业监视和测量设备 - 中国RoHS2公布表

PCB Industrial Monitoring and Measuring Equipment - China RoHS 2 Disclosure Table

部件名称	有害物质					
	铅 (Pb)	汞 (Hg)	镉 (Cd)	六价铬 (Cr(VI))	多溴联苯 (PBB)	多溴二苯醚 (PBDE)
住房	0	0	0	0	0	0
PCB板	X	0	0	0	0	0
电气连接器	0	0	0	0	0	0
压电晶体	X	0	0	0	0	0
环氧	0	0	0	0	0	0
铁氟龙	0	0	0	0	0	0
电子	0	0	0	0	0	0
厚膜基板	0	0	X	0	0	0
电线	0	0	0	0	0	0
电缆	X	0	0	0	0	0
塑料	0	0	0	0	0	0
焊接	X	0	0	0	0	0
铜合金/黄铜	X	0	0	0	0	0
本表格依据 SJ/T 11364 的规定编制。						
0：表示该有害物质在该部件所有均质材料中的含量均在 GB/T 26572 规定的限量要求以下。						
X：表示该有害物质至少在该部件的某一均质材料中的含量超出 GB/T 26572 规定的限量要求。						
铅是欧洲RoHS指令2011/65/ EU附件三和附件四目前由于允许的豁免。						

CHINA RoHS COMPLIANCE

Component Name	Hazardous Substances					
	Lead (Pb)	Mercury (Hg)	Cadmium (Cd)	Chromium VI Compounds (Cr(VI))	Polybrominated Biphenyls (PBB)	Polybrominated Diphenyl Ethers (PBDE)
Housing	O	O	O	O	O	O
PCB Board	X	O	O	O	O	O
Electrical Connectors	O	O	O	O	O	O
Piezoelectric Crystals	X	O	O	O	O	O
Epoxy	O	O	O	O	O	O
Teflon	O	O	O	O	O	O
Electronics	O	O	O	O	O	O
Thick Film Substrate	O	O	X	O	O	O
Wires	O	O	O	O	O	O
Cables	X	O	O	O	O	O
Plastic	O	O	O	O	O	O
Solder	X	O	O	O	O	O
Copper Alloy/Brass	X	O	O	O	O	O

This table is prepared in accordance with the provisions of SJ/T 11364.

O: Indicates that said hazardous substance contained in all of the homogeneous materials for this part is below the limit requirement of GB/T 26572.

X: Indicates that said hazardous substance contained in at least one of the homogeneous materials for this part is above the limit requirement of GB/T 26572.

Lead is present due to allowed exemption in Annex III or Annex IV of the European RoHS Directive 2011/65/EU.

APPLICATION	USED ON	VAR
NEXT ASSY		

PCB Piezotronics Inc. claims proprietary rights in the information disclosed hereon. Neither it nor any reproduction thereof will be disclosed to others without written consent of PCB Piezotronics Inc.

REVISIONS		ECN	DATE	APP'D
ZONE	REV			

14376

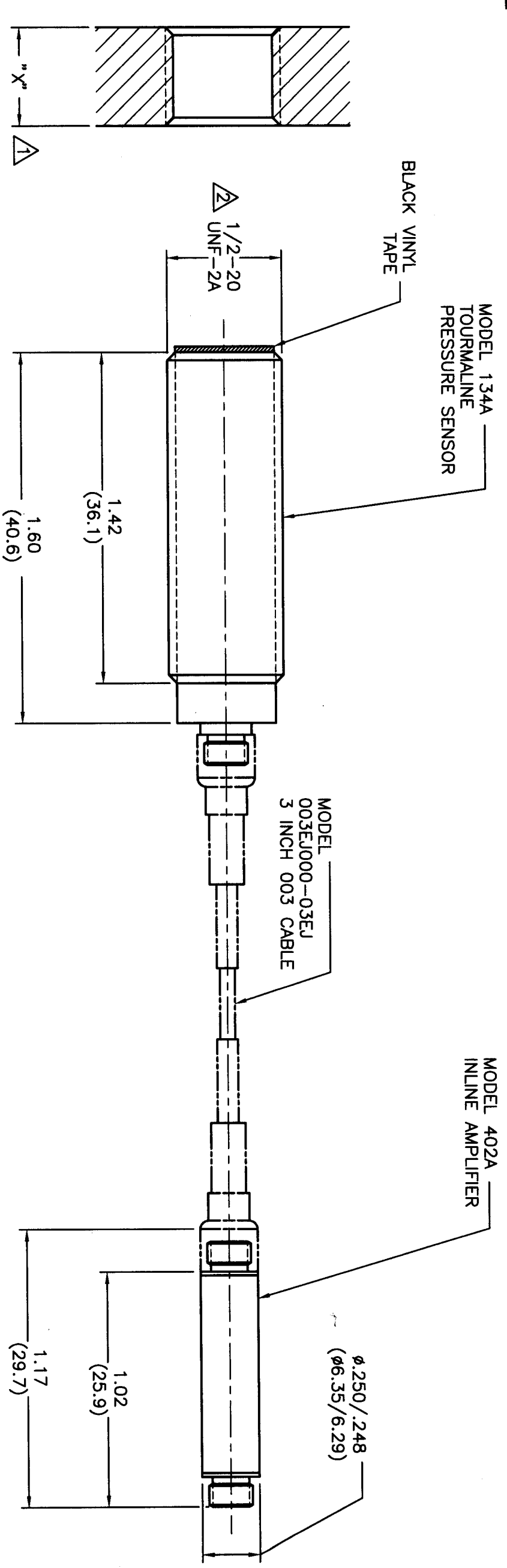

MOUNTING HOLE PREPARATION:  
 Ø.453  
 THRU  
 TAP 1/2-20 UNF-2B

TEFLON TAPE OR OTHER THREAD SEALANT IS RECOMMENDED  
 "X" DIMENSION TO SUIT USER REQUIREMENTS

UNLESS SPECIFIED TOLERANCES		DIMENSIONS IN MILLIMETERS		DRAWN		MFG		DATE		PCB PIEZOTRONICS	
DIMENSIONS IN INCHES		(IN PARENTHESES)		CHK'D		ENGR		12/21/02		3425 WALDEN AVE. DEPT. NY 14043	
DECIMALS XX ±.01		DECIMALS XX ±0.3		DM				9/20/02		(716) 694-0001 EMAIL: SALES@PCB.COM	
XXX ±.005		XXX ±0.13		APP'D		ENGR		10/21/02		CODE	
ANGLES ±2 DEGREES		ANGLES ±2 DEGREES		TITLE		MFG		10/21/02		IDENT. NO.	
FILETS AND RADII		FILETS AND RADII		INSTALLATION DRAWING		MFG				DWG. NO.	
.003 - .005		(0.07 - 0.13)		MODEL 134A24		MFG				14376	
				PRESSURE SENSOR		MFG				SCALE: 2x	
DD012 REV. B 03/13/98										SHEET 1 OF 1	