



**Model 123B23**

**Rocket motor ICP® pressure sensor 10k psi 0.5mV/psi Helium bleed water-cooled (replaceable tubes)**

**Installation and Operating Manual**

**For assistance with the operation of this product,  
contact the PCB Piezotronics, Inc.**

**Toll-free: 716-684-0001  
24-hour SensorLine: 716-684-0001  
Fax: 716-684-0987  
E-mail: [info@pcb.com](mailto:info@pcb.com)  
Web: [www.pcb.com](http://www.pcb.com)**



## Repair and Maintenance

PCB guarantees Total Customer Satisfaction through its “Lifetime Warranty Plus” on all Platinum Stock Products sold by PCB and through its limited warranties on all other PCB Stock, Standard and Special products. Due to the sophisticated nature of our sensors and associated instrumentation, **field servicing and repair is not recommended and, if attempted, will void the factory warranty.**

Beyond routine calibration and battery replacements where applicable, our products require no user maintenance. Clean electrical connectors, housings, and mounting surfaces with solutions and techniques that will not harm the material of construction. Observe caution when using liquids near devices that are not hermetically sealed. Such devices should only be wiped with a dampened cloth—never saturated or submerged.

In the event that equipment becomes damaged or ceases to operate, our Application Engineers are here to support your troubleshooting efforts 24 hours a day, 7 days a week. Call or email with model and serial number as well as a brief description of the problem.

## Calibration

Routine calibration of sensors and associated instrumentation is necessary to maintain measurement accuracy. We recommend calibrating on an annual basis, after exposure to any extreme environmental influence, or prior to any critical test.

PCB Piezotronics is an ISO-9001 certified company whose calibration services are accredited by A2LA to ISO/IEC 17025, with full traceability to SI through N.I.S.T. In addition to our standard calibration services, we also offer specialized tests, including: sensitivity at elevated or cryogenic temperatures, phase response, extended high or low frequency response, extended range, leak testing, hydrostatic pressure testing, and others. For more information, contact your local PCB Piezotronics distributor, sales representative, or factory customer service representative.

## Returning Equipment

If factory repair is required, our representatives will provide you with a Return Material Authorization (RMA) number, which we use to reference any information you have already provided and expedite the repair process. This number should be clearly marked on the outside of all returned package(s) and on any packing list(s) accompanying the shipment.

## Contact Information

PCB Piezotronics, Inc.  
3425 Walden Ave.  
Depew, NY14043 USA  
Toll-free: (800) 828-8840  
24-hour SensorLine: (716) 684-0001  
General inquiries: [info@pcb.com](mailto:info@pcb.com)  
Repair inquiries: [rma@pcb.com](mailto:rma@pcb.com)

For a complete list of distributors, global offices and sales representatives, visit our website, [www.pcb.com](http://www.pcb.com).

## Safety Considerations

This product is intended for use by qualified personnel who recognize shock hazards and are familiar with the precautions required to avoid injury. While our equipment is designed with user safety in mind, the protection provided by the equipment may be impaired if equipment is used in a manner not specified by this manual.

Discontinue use and contact our 24-Hour Sensorline if:

- Assistance is needed to safely operate equipment
- Damage is visible or suspected
- Equipment fails or malfunctions

For complete equipment ratings, refer to the enclosed specification sheet for your product.

## Definition of Terms and Symbols

The following symbols may be used in this manual:



### **DANGER**

Indicates an immediate hazardous situation, which, if not avoided, may result in death or serious injury.

**CAUTION**

Refers to hazards that could damage the instrument.

**NOTE**

Indicates tips, recommendations and important information. The notes simplify processes and contain additional information on particular operating steps.

**The following symbols may be found on the equipment described in this manual:**



This symbol on the unit indicates that high voltage may be present. Use standard safety precautions to avoid personal contact with this voltage.



This symbol on the unit indicates that the user should refer to the operating instructions located in the manual.



This symbol indicates safety, earth ground.



PCB工业监视和测量设备 - 中国RoHS2公布表

PCB Industrial Monitoring and Measuring Equipment - China RoHS 2 Disclosure Table

部件名称	有害物质					
	铅 (Pb)	汞 (Hg)	镉 (Cd)	六价铬 (Cr(VI))	多溴联苯 (PBB)	多溴二苯醚 (PBDE)
住房	0	0	0	0	0	0
PCB板	X	0	0	0	0	0
电气连接器	0	0	0	0	0	0
压电晶体	X	0	0	0	0	0
环氧	0	0	0	0	0	0
铁氟龙	0	0	0	0	0	0
电子	0	0	0	0	0	0
厚膜基板	0	0	X	0	0	0
电线	0	0	0	0	0	0
电缆	X	0	0	0	0	0
塑料	0	0	0	0	0	0
焊接	X	0	0	0	0	0
铜合金/黄铜	X	0	0	0	0	0
本表格依据 SJ/T 11364 的规定编制。						
0：表示该有害物质在该部件所有均质材料中的含量均在 GB/T 26572 规定的限量要求以下。						
X：表示该有害物质至少在该部件的某一均质材料中的含量超出 GB/T 26572 规定的限量要求。						
铅是欧洲RoHS指令2011/65/ EU附件三和附件四目前由于允许的豁免。						

CHINA RoHS COMPLIANCE

Component Name	Hazardous Substances					
	Lead (Pb)	Mercury (Hg)	Cadmium (Cd)	Chromium VI Compounds (Cr(VI))	Polybrominated Biphenyls (PBB)	Polybrominated Diphenyl Ethers (PBDE)
Housing	O	O	O	O	O	O
PCB Board	X	O	O	O	O	O
Electrical Connectors	O	O	O	O	O	O
Piezoelectric Crystals	X	O	O	O	O	O
Epoxy	O	O	O	O	O	O
Teflon	O	O	O	O	O	O
Electronics	O	O	O	O	O	O
Thick Film Substrate	O	O	X	O	O	O
Wires	O	O	O	O	O	O
Cables	X	O	O	O	O	O
Plastic	O	O	O	O	O	O
Solder	X	O	O	O	O	O
Copper Alloy/Brass	X	O	O	O	O	O

This table is prepared in accordance with the provisions of SJ/T 11364.

O: Indicates that said hazardous substance contained in all of the homogeneous materials for this part is below the limit requirement of GB/T 26572.

X: Indicates that said hazardous substance contained in at least one of the homogeneous materials for this part is above the limit requirement of GB/T 26572.

Lead is present due to allowed exemption in Annex III or Annex IV of the European RoHS Directive 2011/65/EU.

# OPERATION MANUAL FOR HELIUM BLEED WATER-COOLED PRESSURE SENSORS 123 Series

## 1.0 INTRODUCTION

The series of sensors described in this guide is designed to measure dynamic pressures in intense thermal environments typified by rocket engine combustion chambers.

These sensors feature acceleration-compensated piezoelectric pressure probes mounted in a helium bleed adaptor with water cooling.

The helium gas, applied from a 1500 psi source, is metered by a built-in orifice and flows around the probe body and out the passage of the adaptor head of the probe diaphragm. The helium gas flowing out the passage protects the sensor diaphragm from the hot gasses as well as increasing the natural frequency of the passage by a factor of approximately three to one.

## 2.0 DESCRIPTION

The charge-mode models contain a one pC/psi pressure probe (sensor) and is designed to be used with electrostatic charge amplifiers.

The ICP® Models contain built-in impedance converter electronics circuits which convert the high-impedance voltage from the quartz crystal to a low-impedance voltage signal that can be fed directly into most common indicating or recording instruments.

The 123 Series sensors contain a 10 micro helium filter contained in a fitting threaded onto the helium input tube. The purpose of this filter is to prevent particles in the helium supply from plugging the metering orifice.

The outer body of this series is 17-4 PH hardened stainless steel and features a ceramic-coated tip for protection against erosion by hot gasses when the sensor is flush-mounted directly in combustion chambers.

The probes in all models are electrically ground isolated from the outer housing.

NOTE: The sensor probe in this series is factory installed at a precise depth in the outer body. Do not attempt removal of this probe. Contact the factory should any questions or problems arise concerning the sensor probe.

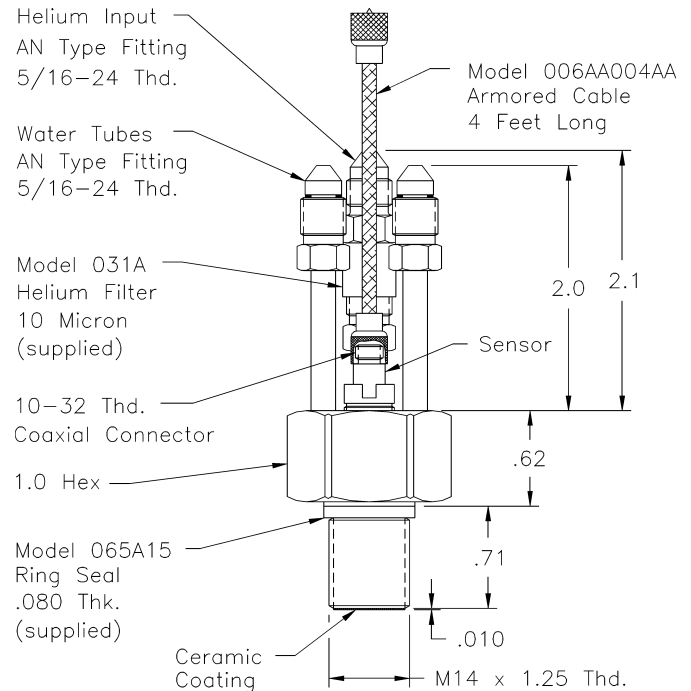

**123 Series: Water-Cooled & Helium Bleed Rocket Motor, ICP® and Charge Sensors**

## 3.0 INSTALLATION

Prepare mounting port in accordance with instructions on the installation drawing

Inspect the mounting port for burrs and tool marks at the seal surface.

Use recommended mounting torque when installing sensors. Do not over torque as damage to seal surface could result.

NOTE: When attaching helium supply hose, do not torque hose fitting through helium tube on sensor. Back up fitting with wrench on 3/8 hex on helium hose fitting. (Refer to note 3 on installation drawing.)

Especially in the presence of high vibration, support helium supply tubes by clamping to rigid surfaces with adequate strain relief loop to avoid stressing helium tube on sensor.

Follow the same procedures and apply similar precautions when installing the water supply and drain hoses. Either water tube may be used as the

**OPERATION MANUAL FOR  
HELIUM BLEED WATER-COOLED  
PRESSURE SENSORS  
123 Series**

inlet tube. Use at least a 50 psi source of clean water for cooling.

For charge-mode models, connect 4 ft. cable to charge amplifier and switch to "LONG" time constant position and check for drift.

Clean cable connections with Tryclor<sup>®</sup> or equivalent solvent to restore insulation resistance.

It is good practice to depress ground button (or place switch in "GND" position) on the charge amplifier while attaching input cables to the amplifier. This will prevent spurious charges which may accumulate on sensors and cables from blowing out the input circuitry of the charge amplifier.

Since the charge output sensors are susceptible to decreased insulation resistance, use care to keep cable connections clean by use of shrink tubing wherever possible.

The ICP<sup>®</sup> Series Sensors use low-output impedance probes (ICP<sup>®</sup>) and will not require the insulation resistance cautions previously described for the charge-mode models.

Connect the sensor cable to the appropriate ICP<sup>®</sup> power unit and check the front panel monitor meter to check cable connections and internal amplifier.

Consult Guide G-0001B, "General Guide to ICP<sup>®</sup> Instrumentation" for installation and usage hints for ICP<sup>®</sup> instruments.

## 4.0 OPERATION

### 4.1 CHARGE OUTPUT MODEL

For the charge-mode, it is only necessary to select the proper range on the charge amplifier and proceed with the measurement.

The probe sensitivity is approximately 1.0 pC/psi. (The exact sensitivity is given on the calibration certificate supplied with each instrument.)

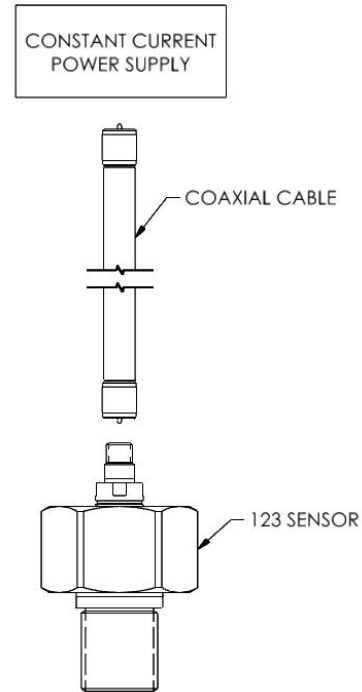

### Sensor connection for ICP<sup>®</sup> operation

EXAMPLE: The dynamic pressure expected is 500 psi and the desired output voltage for this pressure is 1 volt.

Simply set the range switch of the charge amplifier to 500 units per volt and dial the standardization pot to the exact sensor sensitivity at 500 psi (from calibration graph).

The system will then yield exactly 1 volt for 500 psi of input pressure (dynamic).

### 4.2 TIME CONSTANT

During in-place calibration static methods (dead weight tester) may be used in a drift-free system by placing the charge amplifier in "LONG TC" position.

However, during actual use, the TC mode switch should be in "SHORT" position for two reasons. Often times, the dynamic pressure being measured exists superimposed upon a higher static level. The short TC position will allow the effect of this static

**OPERATION MANUAL FOR  
HELIUM BLEED WATER-COOLED  
PRESSURE SENSORS  
123 Series**

level to zero out quickly without effect on the dynamic level indicated.

Also, the influx of large amounts of thermal energy, as in rocket combustion measurements, can cause the sensor to generate spurious transient outputs of considerable magnitude. Using the charge amplifier on "SHORT" TC alleviates this problem by shunting these longer term charge outputs to ground while measuring the faster dynamic pressure pulses.

### 4.3 OPERATION - ICP® MODELS

Consult Guide G-0001B for a complete description of the low-impedance concept in instrumentation.

All PCB power units designed for ICP® use contain built-in fault monitor meters to aid in locating circuit faults (shorts or opens) and to identify normal operation of the miniature impedance-converting amplifier built into the sensor.

Do not attempt to apply voltage directly to the input pin of the sensor from any other power source. The input current must be limited to 20 mA maximum and the input voltage must not be higher than 28 VDC. Consult the factory if it is desired to build a power unit rather than to use one of those available from PCB.

NOTE: Full-scale range is limited by the helium source pressure. The applied helium source pressure level must be at least twice the peak combustion pressure (not to exceed 15,000 psi), and not more than 10 times the lowest expected peak combustion pressure. This is true for all models, charge or ICP®.

## 5.0 CALIBRATION

### 5.1 CHARGE MODEL

To calibrate this model, install in pressure port of dead weight tester and apply various static pressures, recording corresponding outputs at each pressure of interest.

Discharge the charge amplifier before each reading and return pressure to zero before each new pressure input. Use the charge amplifier on "LONG" time constant and keep cables and connections clean to avoid drift. A DC digital voltmeter is ideal for readout during calibration.

Drawing Number: 21091  
Revision: B

NOTE: The helium tube must be plugged with a pressure-tight seal before attempting to calibrate to avoid losing pressure through the helium tube.

If a hydraulic calibration system is used, be sure to remove all traces of oil from the diaphragm passage after calibration. Pneumatic systems are preferred for calibration.

## 5.2 ICP® MODELS

Because of the shorter time constants built into these models, static calibration methods are much more difficult to use. Pressures must be applied rapidly and readout must be made with fast recording devices such as light beam oscillographs or storage oscilloscopes.

A pneumatic (compressed air or hydrogen) system with quick opening valve and reference gage is an excellent method of calibrating these sensors.

## MAINTENANCE

The sealed construction and miniature size of these sensors make field repair impractical.

The helium filter element should be cleaned should the flow rate decrease. Remove the element and ultrasonically agitate in solvent for 15 minutes, then dry.

Should the orifice become plugged, back pressure the orifice by applying air pressure to diaphragm end of sensor with filter off and helium tube vented to atmosphere.

The only maintenance possible on the probe is maintaining of insulation resistance of the charge mode models. Clean connectors with suitable solvent and dry.

Contact factory for assistance should problems arise.

®ICP is a registered trademark of PCB Piezotronics



	ENGLISH	SI	
<b>Performance</b>			
Measurement Range(for ±5V output)	10,000 psi	68,950 kPa	
Sensitivity(± 15 %)	0.5 mV/psi	0.07 mV/kPa	
Maximum Pressure	15,000 psi	103,420 kPa	
Resolution	0.2 psi	1.379 kPa	[1]
Resonant Frequency	≥ 25 kHz	≥ 25 kHz	[2]
Rise Time	≤ 20 μ sec	≤ 20 μ sec	[2]
Low Frequency Response(- 5 %)	0.0005 Hz	0.0005 Hz	
Non-Linearity	≤ 1.0 % FS	≤ 1.0 % FS	[3]
<b>Environmental</b>			
Acceleration Sensitivity	≤ 0.002 psi/g	≤ 0.0014 kPa/(m/s <sup>2</sup> )	[4]
Temperature Range(Operating)	-100 to +250 °F	-73 to +121 °C	
Temperature Coefficient of Sensitivity	≤ 0.03 %/°F	≤ 0.054 %/°C	
Maximum Flash Temperature	10,000 °F	5,538 °C	
Maximum Vibration	2,000 g pk	19,600 m/s <sup>2</sup> pk	
Maximum Shock	10,000 g pk	98,070 m/s <sup>2</sup> pk	
<b>Electrical</b>			
Output Polarity(Positive Pressure)	Positive	Positive	
Discharge Time Constant(at room temp)	≥ 1,000 sec	≥ 1,000 sec	
Excitation Voltage	20 to 30 VDC	20 to 30 VDC	
Constant Current Excitation	2 to 20 mA	2 to 20 mA	
Output Impedance	≤ 100 Ohm	≤ 100 Ohm	
Output Bias Voltage	8 to 14 VDC	8 to 14 VDC	
<b>Physical</b>			
Housing Material	17-4 Stainless Steel	17-4 Stainless Steel	
Diaphragm	Invar	Invar	
Sealing	Hermetic	Hermetic	
Electrical Connector	Integral Cable	Integral Cable	
Weight	4.59 oz	130 gm	
Helium Flow Rate(at 1,500 psi)	40 scf/hr	1.13 m <sup>3</sup> /hr	
Water Flow Rate(at 50 psi)	1.2 gal/min	4.5 L/min	
Cable Length	4 ft	1.2 m	

**OPTIONAL VERSIONS**

Optional versions have identical specifications and accessories as listed for the standard model except where noted below. More than one option may be used.

**NOTES:**

[1]Typical.  
 [2]With helium flow.  
 [3]Zero-based, least-squares, straight line method.  
 [4]Applies to internal amplifier, not to external housing.  
 [5]See PCB Declaration of Conformance PS023 for details.

**SUPPLIED ACCESSORIES:**

Model 065A15 Seal, .624" OD x .553" ID x .080", brass (3)  
 Model 065A72 Water cooling tubes (o-ring sealed) (2)  
 Model 070A08 Cable adaptor (micro 10-32 jack to BNC jack) (1)

Entered: ND	Engineer: RPF	Sales: RWM	Approved: RPF	Spec Number:
Date: 01/11/2024	Date: 01/11/2024	Date: 01/11/2024	Date: 01/11/2024	68595

**PCB PIEZOTRONICS**  
 AN AMPHENOL COMPANY

Phone: 716-684-0001  
 Fax: 716-684-0987  
 E-Mail: info@pcb.com

3425 Walden Avenue, Depew, NY 14043



All specifications are at room temperature unless otherwise specified.  
 In the interest of constant product improvement, we reserve the right to change specifications without notice.  
 ICP® is a registered trademark of PCB Piezotronics, Inc.

PCB Piezotronics Inc. claims proprietary rights in the information disclosed hereon. Neither it nor any reproduction thereof will be disclosed to others without the written consent of PCB Piezotronics Inc.

66526

REVISIONS		
REV	DESCRIPTION	DIN
A	UPDATED TITLE BLOCK	47696

4 MODEL 065A72 WATER TUBES (REPLACEABLE) 5/16-24 UNF-2A, AN TYPE FITTING

ELECTRICAL CONNECTOR COAXIAL 10-32 UNF-2A

2X Ø.05 [1.3] THRU SAFETY WIRE HOLE

O-RING (5-669)

6X Ø.05 [1.3] THRU SAFETY WIRE HOLES

2 1.125 [28.58] HEX

M14x1.25 - 6g

MOUNTING HOLE PREPARATION  
M14x1.25-6H THRU  
└┐ ⌀.625±.001 [15.88±.02] ▽.060 [1.52]

FLUSH MOUNT

RECESS MOUNT

MOUNTING HOLE PREPARATION  
Ø.100 [2.54] THRU  
M14x1.25-6H ▽.720 [18.29]  
└┐ ⌀.625±.001 [15.88±.02] ▽.060 [1.52]

4 HELIUM INPUT, AN TYPE FITTING 5/16-24 UNF-2A

MODEL 006EB004EB ARMORED CABLE 4 ft [1.2 M] LONG

HELIUM FILTER (10 MICRON) 3

MODEL 065A15 SEAL (SUPPLIED)

PROTECTIVE CERAMIC COATING

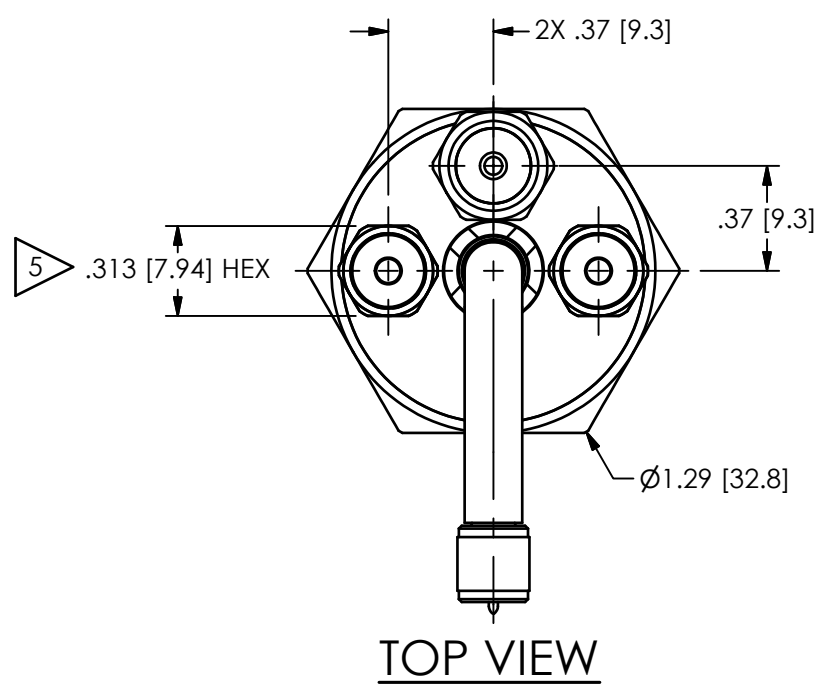

TOP VIEW

- 5 RECOMMENDED MOUNTING TORQUE ON .313 [7.94] HEX: 5-10 inch-lb [.56-1.13 Nm]
- 4 RECOMMENDED MOUNTING TORQUE: 15-30 inch-lb [1.7-3.4 Nm]
- 3 SUPPORT .375 [9.53] HEX ON FILTER WHEN ATTACHING LINE TO AVOID DAMAGE TO HELIUM INPUT TUBE
- 2 RECOMMENDED MOUNTING TORQUE ON 1.125 [28.58] HEX: 125±5 inch-lb [14±.5 Nm]
- 1 SEAL SURFACE MUST BE FLAT AND FREE OF TOOL MARKS WITH A 63 [1.5] FINISH

UNLESS OTHERWISE SPECIFIED TOLERANCES ARE:		DRAWN		CHECKED		ENGINEER	
DIMENSIONS IN INCHES	DIMENSIONS IN MILLIMETERS [IN BRACKETS]	KRM	1/15/18	KRM	1/15/18	DRK	1/15/18
DECIMALS XX ±.01 XXX ±.005	DECIMALS X ±.03 XX ±.013	TITLE					
ANGLES ± 2 DEGREES	ANGLES ± 2 DEGREES	INSTALLATION DRAWING SERIES 123B HELIUM BLEED WATER COOLED SENSOR					
FILLETS AND RADII .003 - .005	FILLETS AND RADII 0.07 - 0.13	CODE IDENT. NO. 52681		DWG. NO. 66526		3425 WALDEN AVE. DEPEW, NY 14043 (716) 684-0001 E-MAIL: sales@pcb.com	
		SCALE: 1.5X		SHEET 1 OF 1			