



**Model 106B**

**ICP® Acoustic Pressure Sensor, 300 mV/psi, resolution 0.0001 psi (+91 dB), accel. comp.**

**Installation and Operating Manual**

**For assistance with the operation of this product,  
contact the PCB Piezotronics, Inc.**

**Toll-free: 716-684-0001**

**24-hour SensorLine: 716-684-0001**

**Fax: 716-684-0987**

**E-mail: [info@pcb.com](mailto:info@pcb.com)**

**Web: [www.pcb.com](http://www.pcb.com)**



## Repair and Maintenance

PCB guarantees Total Customer Satisfaction through its “Lifetime Warranty Plus” on all Platinum Stock Products sold by PCB and through its limited warranties on all other PCB Stock, Standard and Special products. Due to the sophisticated nature of our sensors and associated instrumentation, **field servicing and repair is not recommended and, if attempted, will void the factory warranty.**

Beyond routine calibration and battery replacements where applicable, our products require no user maintenance. Clean electrical connectors, housings, and mounting surfaces with solutions and techniques that will not harm the material of construction. Observe caution when using liquids near devices that are not hermetically sealed. Such devices should only be wiped with a dampened cloth—never saturated or submerged.

In the event that equipment becomes damaged or ceases to operate, our Application Engineers are here to support your troubleshooting efforts 24 hours a day, 7 days a week. Call or email with model and serial number as well as a brief description of the problem.

## Calibration

Routine calibration of sensors and associated instrumentation is necessary to maintain measurement accuracy. We recommend calibrating on an annual basis, after exposure to any extreme environmental influence, or prior to any critical test.

PCB Piezotronics is an ISO-9001 certified company whose calibration services are accredited by A2LA to ISO/IEC 17025, with full traceability to SI through N.I.S.T. In addition to our standard calibration services, we also offer specialized tests, including: sensitivity at elevated or cryogenic temperatures, phase response, extended high or low frequency response, extended range, leak testing, hydrostatic pressure testing, and others. For more information, contact your local PCB Piezotronics distributor, sales representative, or factory customer service representative.

## Returning Equipment

If factory repair is required, our representatives will provide you with a Return Material Authorization (RMA) number, which we use to reference any information you have already provided and expedite the repair process. This number should be clearly marked on the outside of all returned package(s) and on any packing list(s) accompanying the shipment.

## Contact Information

PCB Piezotronics, Inc.  
3425 Walden Ave.  
Depew, NY14043 USA  
Toll-free: (800) 828-8840  
24-hour SensorLine: (716) 684-0001  
General inquiries: [info@pcb.com](mailto:info@pcb.com)  
Repair inquiries: [rma@pcb.com](mailto:rma@pcb.com)

For a complete list of distributors, global offices and sales representatives, visit our website, [www.pcb.com](http://www.pcb.com).

## Safety Considerations

This product is intended for use by qualified personnel who recognize shock hazards and are familiar with the precautions required to avoid injury. While our equipment is designed with user safety in mind, the protection provided by the equipment may be impaired if equipment is used in a manner not specified by this manual.

Discontinue use and contact our 24-Hour Sensorline if:

- Assistance is needed to safely operate equipment
- Damage is visible or suspected
- Equipment fails or malfunctions

For complete equipment ratings, refer to the enclosed specification sheet for your product.

## Definition of Terms and Symbols

The following symbols may be used in this manual:



### **DANGER**

Indicates an immediate hazardous situation, which, if not avoided, may result in death or serious injury.

**CAUTION**

Refers to hazards that could damage the instrument.

**NOTE**

Indicates tips, recommendations and important information. The notes simplify processes and contain additional information on particular operating steps.

**The following symbols may be found on the equipment described in this manual:**



This symbol on the unit indicates that high voltage may be present. Use standard safety precautions to avoid personal contact with this voltage.



This symbol on the unit indicates that the user should refer to the operating instructions located in the manual.



This symbol indicates safety, earth ground.



PCB工业监视和测量设备 - 中国RoHS2公布表

PCB Industrial Monitoring and Measuring Equipment - China RoHS 2 Disclosure Table

部件名称	有害物质					
	铅 (Pb)	汞 (Hg)	镉 (Cd)	六价铬 (Cr(VI))	多溴联苯 (PBB)	多溴二苯醚 (PBDE)
住房	0	0	0	0	0	0
PCB板	X	0	0	0	0	0
电气连接器	0	0	0	0	0	0
压电晶体	X	0	0	0	0	0
环氧	0	0	0	0	0	0
铁氟龙	0	0	0	0	0	0
电子	0	0	0	0	0	0
厚膜基板	0	0	X	0	0	0
电线	0	0	0	0	0	0
电缆	X	0	0	0	0	0
塑料	0	0	0	0	0	0
焊接	X	0	0	0	0	0
铜合金/黄铜	X	0	0	0	0	0
本表格依据 SJ/T 11364 的规定编制。						
0：表示该有害物质在该部件所有均质材料中的含量均在 GB/T 26572 规定的限量要求以下。						
X：表示该有害物质至少在该部件的某一均质材料中的含量超出 GB/T 26572 规定的限量要求。						
铅是欧洲RoHS指令2011/65/ EU附件三和附件四目前由于允许的豁免。						

CHINA RoHS COMPLIANCE

Component Name	Hazardous Substances					
	Lead (Pb)	Mercury (Hg)	Cadmium (Cd)	Chromium VI Compounds (Cr(VI))	Polybrominated Biphenyls (PBB)	Polybrominated Diphenyl Ethers (PBDE)
Housing	O	O	O	O	O	O
PCB Board	X	O	O	O	O	O
Electrical Connectors	O	O	O	O	O	O
Piezoelectric Crystals	X	O	O	O	O	O
Epoxy	O	O	O	O	O	O
Teflon	O	O	O	O	O	O
Electronics	O	O	O	O	O	O
Thick Film Substrate	O	O	X	O	O	O
Wires	O	O	O	O	O	O
Cables	X	O	O	O	O	O
Plastic	O	O	O	O	O	O
Solder	X	O	O	O	O	O
Copper Alloy/Brass	X	O	O	O	O	O

This table is prepared in accordance with the provisions of SJ/T 11364.

O: Indicates that said hazardous substance contained in all of the homogeneous materials for this part is below the limit requirement of GB/T 26572.

X: Indicates that said hazardous substance contained in at least one of the homogeneous materials for this part is above the limit requirement of GB/T 26572.

Lead is present due to allowed exemption in Annex III or Annex IV of the European RoHS Directive 2011/65/EU.

# OPERATION MANUAL FOR HIGH INTENSITY MICROPHONES MODELS 106B, 106B10, 106B50

## 1.0 INTRODUCTION

The Series 106B microphones feature high-sensitivity, acceleration-compensated quartz pressure elements coupled to built-in integrated circuit impedance converting amplifiers.

These very sensitive sensors are designed to measure pressure perturbations in air or in fluids in severe environments. They can also be used to measure very small pressure disturbances on a much higher static head, with certain precautions.

## 2.0 DESCRIPTION

The quartz elements in the 106B Series utilize a special cut in quartz to produce a proportionately higher output voltage than the standard X-cut compression crystals normally used.

A built-in seismic mass acting on another quartz crystal effectively cancels the spurious signal produced by the mass of the diaphragm and end piece acting upon the very sensitive crystals in the presence of axial vibration inputs.

This design produces an extremely high level output signal with good resolution, relatively free from unwanted vibration effects.

As with all quartz sensors, the high rigidity results in negligible diaphragm motion producing excellent linearity from the threshold pressure to full-scale pressure. The high rigidity of quartz also results in sensors with high natural frequency, giving a very wide useful frequency range.

Although the same basic quartz element is used in both models, the sensitivity of the 106B50 is twice that of the 106B, the result of a larger diaphragm area in the B50.

The Model 106B10 consists of the Model 106B element in a customized package specifically designed for paper mill headbox measurements. The built-in electronics consist of a low-noise MOSFET input source follower with unity gain. A single wire feeds constant current power to the source of the FET and also carries the dynamic signal, superimposed on the +3 to +5 bias.

See "Guide to ICP<sup>®</sup> Instrumentation, G-0001B" for a more complete treatment of the "Integrated Circuit Piezoelectric" (ICP<sup>®</sup>) concept.

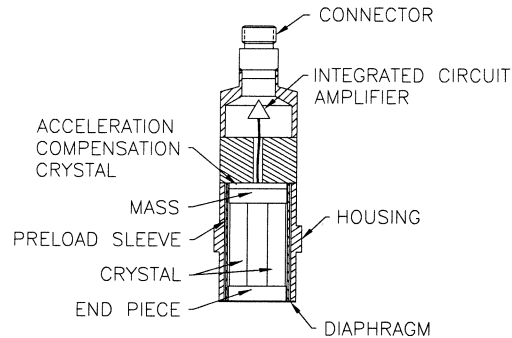

Cross Section: Series 106B Microphone Element

## 3.0 POLARITY

Both models produce a positive-going output signal with increasing pressure at the diaphragm. Since the bias voltage of the low-noise electronics is rather low compared to other ICP<sup>®</sup> instruments, the output voltage capability is nonsymmetrical, i.e. the units can produce positive-going voltages to 12 or 13 volts with a +18 V battery supply, but the linear negative-going output voltage is limited to approximately 2.5 volts.

This is not a disadvantage because +2.5 volts provide an adequate output signal for most microphone applications and the higher positive-going voltage affords an ability to measure much higher positive-going pulses if desirable.

## 4.0 POWER UNITS

In general, it is advisable to use battery-powered signal conditioners (such as the 480C02) to power the Series 106 microphones because of their inherently low noise.

If line powering is desirable, consult the factory for help in selecting the best signal conditioner for the application.

# OPERATION MANUAL FOR HIGH INTENSITY MICROPHONES MODELS 106B, 106B10, 106B50

These sensors must only be powered through constant-current diodes or other equivalent current-limiting circuitry, (2 to 20 mA) as contained in all PCB signal conditioners.

**CAUTION:** Never apply power directly to the center pin of the connector without the current-limiting protection (2 mA maximum), as to do so will destroy the built-in amplifier.

Connect the microphones to the power unit as shown in the figure below.

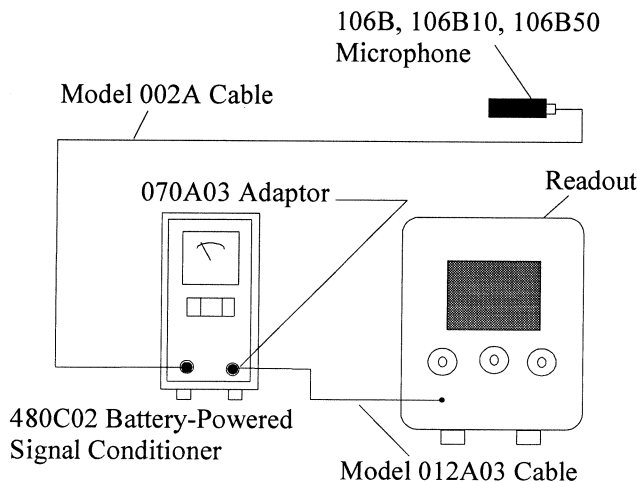

**Typical Power Connection**

The 106B, 106B10, and 106B50 differ from the standard ICP<sup>®</sup> sensors in that the low noise, built-in amplifiers have a +3 to +5 V bias or turn-on voltage instead of the usual +11 V bias. Consequently, the bias monitor voltmeter located on the front panel of most PCB signal conditioners will indicate approximately 20% full scale under normal operating conditions, rather than the mid-scale reading associated with normal operation for other ICP<sup>®</sup> instruments.

A full-scale reading on the bias monitor meter indicates an open circuit between the signal conditioner and sensor.

A zero reading indicates a short circuit in cable, connections, or sensor.

## 5.0 INSTALLATION

Consult the applicable installation drawing at the front of this manual for details on the preparation of mounting ports. For best high-frequency response, flush mounting of the diaphragm is desirable.

The standard type of mounting arrangement for these microphones is by use of the hollow clamp nut supplied (refer to installation drawing), but other methods of mounting the units are acceptable.

Non-metallic mounting adaptors for off-ground installations are available. Consult factory with your specific installation problem.

## 6.0 CALIBRATION

The 106B, 106B10, and 106B50 are calibrated by dynamic means over the full range by subjecting the unit to a series of calibrated pneumatic pressure steps. In addition, the units are given a 124 dB sound pressure level calibration at 250 Hz with a pistonphone. An electrostatic calibration is used to verify the sensor's frequency response.

Recalibration service is offered by PCB. Consult the factory for details.

## 7.0 MEASURING SMALL PRESSURE FLUCTUATIONS ON A HIGH STATIC HEAD

It is possible to measure small dynamic pressure variations superimposed upon a high static (pneumatic or hydraulic) head, but care must be exercised during application and removal of the static pressure to avoid destroying the input MOSFET amplifier.

The important point is to apply and release the static head slowly to allow the resistor across the quartz crystal to bleed off the charge and avoid a voltage build-up that can punch through the gate structure of the MOSFET, rendering it inoperative. (Approximately 100 V maximum rating.)

**OPERATION MANUAL FOR  
HIGH INTENSITY MICROPHONES  
MODELS 106B, 106B10, 106B50**

For the high sensitivity 106B50 (500 mV/psi), keep the rate of pressure application and removal below 200 psi/sec and do not exceed the maximum pressure rating of the unit. Remember that this rate must not be exceeded during removal of the static head as well as during application.

©ICP is a registered trademark of PCB Piezotronics

For the lower sensitivity 106B and 106B10, do not exceed a pressure application or removal rate of 300 psi/sec.

After the high static head is applied, allow time for all coupling capacitors in the readout circuit to fully charge (signified by an end to the apparent "drift" of the output signal), then proceed with the measurement.

## **8.0 MAINTENANCE**

The sealed construction of the 106B Series precludes field maintenance and repair.

Should the time constant degrade or should an abnormality appear in the normal bias voltage, bake the unit in a +250 °F oven for 1 to 2 hours, then retest.

If this does not remove the problem, or should other problems occur, contact the factory for assistance in tracing the problem or for instructions on returning the unit for repair or replacement.

## **9.0 PRECAUTIONS**

1. Do not apply voltage to the units without a current-limiting device (20 mA maximum) in the line, such as is incorporated in all PCB signal conditioners. To do so will destroy the built-in amplifier.
2. Do not subject these sensors to temperatures exceeding 250 °F.
3. Use caution when applying and releasing high static pressures (as outlined in Section 7.0 of this guide) to avoid destroying built-in amplifier.
4. Do not exceed maximum pressure rating.





PCB Piezotronics Inc. claims proprietary rights in the information disclosed herein. Neither it nor any reproduction thereof will be disclosed to others without the written consent of PCB Piezotronics Inc.

REVISIONS		
REV	DESCRIPTION	DIN
F	CORRECT UNIT CONVERSION	52254

18893

ELECTRICAL CONNECTOR  
10-32 UNF - 2A

2 MODEL 060A14  
CLAMP NUT 14mm HEX  
ST STL (SUPPLIED)

M14x1.25 - 6g

MODEL 065A37  
SEAL .025 [0.64] THICK  
BRASS (SUPPLIED)

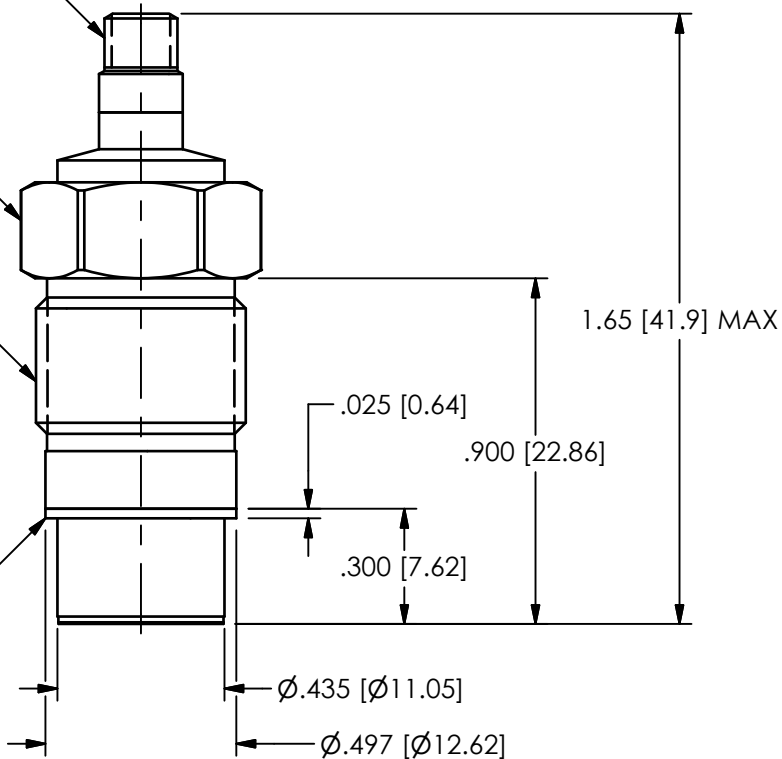

1 MOUNTING HOLE PREPARATION  
Ø.437±.001 [11.10±.025] THRU  
└─┴─┘ Ø.500 [12.70] ▽.600 [15.24]  
M14x1.25-6H ▽.450 [11.43]

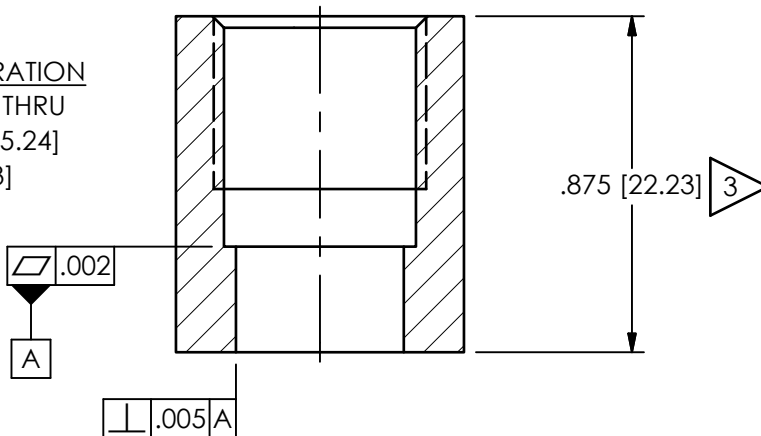

- 3 DIMENSIONS SHOWN ARE FOR .875 [22.23] THICK WALL. COUNTERBORE FOR THICKER WALLS
- 2 RECOMMENDED MOUNTING TORQUE ON A 14mm HEX: 5-6 FT LBS (7-8 NEWTON METERS)
- 1 SEAL SURFACE MUST BE FREE OF TOOL MARKS WITH A MINIMUM  $\sqrt{63}$

UNLESS OTHERWISE SPECIFIED TOLERANCES ARE:		DRAWN		CHECKED		ENGINEER		<b>PCB PIEZOTRONICS</b> AN AMPHENOL COMPANY 3425 WALDEN AVE. DEPEW, NY 14043 (716) 684-0001 E-MAIL: sales@pcb.com	
DIMENSIONS IN INCHES DECIMALS XX ±.01 XXX ±.005 ANGLES ± 2 DEGREES	DIMENSIONS IN MILLIMETERS [IN BRACKETS] DECIMALS X ± 0.3 XX ± 0.13 ANGLES ± 2 DEGREES	KSR	10/22/21	KSR	10/22/21	RF	10/22/21		
CABLE TOLERANCES IN ENGLISH 1" ≤ LENGTH < 1' = +1"/-0 1' ≤ LENGTH < 5' = +2"/-0 5' ≤ LENGTH < 100' = +6"/-0 100' ≤ LENGTH = +1"/-0	CABLE TOLERANCES IN METRIC 2.54cm ≤ LENGTH < 30.5cm = +2.54cm/-0 30.5cm ≤ LENGTH < 1.5m = +5.1cm/-0 1.5m ≤ LENGTH < 30.5m = +15.2cm/-0 30.5m ≤ LENGTH = +30.5cm/-0	TITLE INSTALLATION DRAWING MODEL M106B PRESSURE SENSOR						CODE IDENT. NO. 52681	DWG. NO. 18893
FILLETS AND RADII .003 - .005	FILLETS AND RADII 0.07 - 0.13							SCALE: 2X	

106-2010-90

PCB Piezotronics Inc. claims proprietary rights in the information disclosed herein. Neither it nor any reproduction thereof will be disclosed to others without the written consent of PCB Piezotronics Inc.

REVISIONS		
REV	DESCRIPTION	DIN
G	UPDATED METRIC OAL DIMENSION	55675

2 MODEL 060A12  
CLAMP NUT 9/16 HEX  
[14.28 HEX]  
ST STL (SUPPLIED)

9/16-18 UNF - 2A

MODEL 065A37  
SEAL .025 [.64] THICK  
BRASS (SUPPLIED)

Ø.435 [Ø11.05]

Ø.497 [Ø12.62]

1.65 [41.9] MAX

.900 [22.86]

.025 [.64]

.300 [7.62]

1 MOUNTING HOLE PREPARATION  
Ø.437±.001 [11.10±.025] THRU  
LØ.515 [13.08] ▽.600 [15.24]  
9/16-18 UNF-2B ▽.450 [11.43]

▱.002

A

⊥.005A

.875 [22.23]

3

- 3 DIMENSIONS SHOWN ARE FOR .875 [22.23] THICK WALL. COUNTERBORE FOR THICKER WALLS
- 2 RECOMMENDED MOUNTING TORQUE ON A 9/16 HEX: 5-6 FT LBS [.691 - .830 METER KILOGRAMS]
- 1 SEAL SURFACE MUST BE FREE OF TOOL MARKS WITH A MINIMUM  $63^\circ$

UNLESS OTHERWISE SPECIFIED TOLERANCES ARE:		DRAWN		CHECKED		ENGINEER		PCB PIEZOTRONICS		
DIMENSIONS IN INCHES	DIMENSIONS IN MILLIMETERS [IN BRACKETS]	AME	4/9/25	JDM	4/9/25	RF	4/9/25	AN AMPHENOL COMPANY		
DECIMALS XX ±.01 XXX ±.005	DECIMALS X ±0.3 XX ±0.13	TITLE						3425 WALDEN AVE. DEPEW, NY 14043		
ANGLES ± 2 DEGREES	ANGLES ± 2 DEGREES							716) 684-0001 E-MAIL: sales@pcb.com		
CABLE TOLERANCES IN ENGLISH	CABLE TOLERANCES IN METRIC	INSTALLATION DRAWING MODEL 106B PRESSURE SENSOR						CODE IDENT. NO.	SIZE	DWG. NO.
1" ≤ LENGTH < 1' = +1"/-0	2.54cm ≤ LENGTH < 30.5cm = +2.54cm/-0							52681	A	106-2010-90
1' ≤ LENGTH < 5' = +2"/-0	30.5cm ≤ LENGTH < 1.5m = +5.1cm/-0	SCALE: 2X		SHEET 1 OF 1						
5' ≤ LENGTH < 100' = +6"/-0	1.5m ≤ LENGTH < 30.5m = +15.2cm/-0									
100' ≤ LENGTH = +1"/-0	30.5m ≤ LENGTH = +30.5cm/-0									
FILLETS AND RADII .003 - .005	FILLETS AND RADII 0.07 - 0.13									