

PCB Piezotronics Inc. claims proprietary rights in the information disclosed hereon. Neither it nor any reproduction thereof will be disclosed to others without the written consent of PCB Piezotronics Inc.

REVISIONS

REV	DESCRIPTION	ECN	APP'D
A	UPDATE EXTENDER	15984	DM 9/02
B	ADD FIELD NOTE 5	27903	DM 1/08

7586

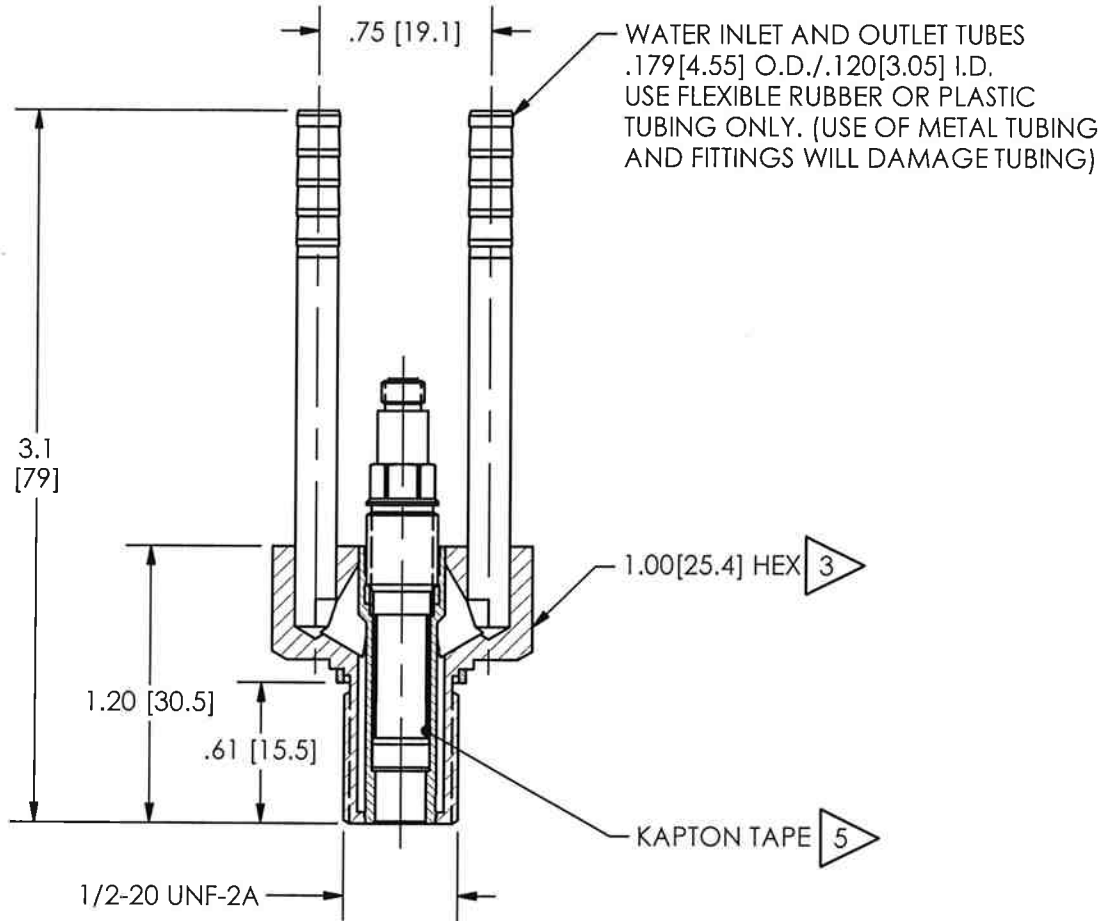

MOUNTING HOLE PREPARATION

- 1 Ø.453 [11.51] THRU
- 2 LØ.562 [14.28] X .050 [1.27] ▽
- 1/2-20 UNF-2B THRU

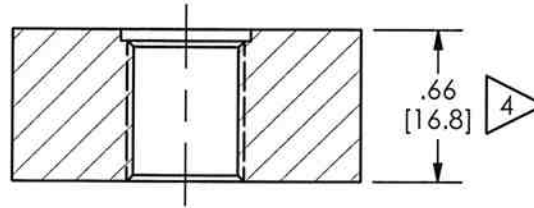

5 ONLY SUPPLIED WITH OFF GROUND OPTION.

4 INSTALLATION FOR WALL THICKNESS OF .66 [16.8]. LØ.1.325 [33.65] FOR THICKER WALLS TO CLEAR 1.00 [25.4] HEX.

3 RECOMMENDED MOUNTING TORQUE ON 1.00 [25.4] HEX: 10-15 FT LBS [14-20 Nm]

2 SEAL SURFACE SHOULD BE FLAT AND FREE OF TOOL MARKS TO WITHIN .001 [.03] TIR WITH A MIN 63 [1.6] ✓ FOR BEST RESULTS.

1 THESE DIAMETERS TO BE CONCENTRIC TO WITHIN .001 [.03] TIR.

UNLESS OTHERWISE SPECIFIED TOLERANCES ARE:

DIMENSIONS IN INCHES

DECIMALS XX ± .01
XXX ± .005
ANGLES ± 2 DEGREES

DIMENSIONS IN MILLIMETERS [IN BRACKETS]

DECIMALS X ± 0.3
XX ± 0.13
ANGLES ± 2 DEGREES

FILLETS AND RADII
.003 - .005

FILLETS AND RADII
[0.07 - 0.13]

DRAWN	ECB	1/3/08	MFG	PRR	1/3/08
CHK'D	DM	1/3/08	ENGR	RF	1/3/08
APP'D	NJL	1/3/08	SALES	DPC	1/3/08

TITLE
INSTALLATION DRAWING
MODEL 064B02 FLUSH MOUNTED
WATER COOLED ADAPTOR

PCB PIEZOTRONICS INC.

3425 WALDEN AVE. DEPEW, NY 14043
(716) 684-0001 E-MAIL: sales@pcb.com

CODE IDENT. NO. 52681 DWG. NO. 7586

SCALE: FULL SHEET 1 OF 2

PCB Piezotronics Inc. claims proprietary rights in the information disclosed hereon. Neither it nor any reproduction thereof will be disclosed to others without the written consent of PCB Piezotronics Inc.

REVISIONS

REV	DESCRIPTION	ECN	APP'D
	- SEE SHEET ONE -		DM 1/08

7586

MODEL 060A03
CLAMP NUT
.250[6.35] HEX
5/16-24 UNF-2A THREAD
(NOT SUPPLIED)

MODEL 070A04
CONNECTOR EXTENDER
10-32 UNF-2A THREAD
(SUPPLIED)

MODEL 069A02
SPACER SLEEVE
.532[13.51] LONG
(SUPPLIED)

MODEL 065A08
SEAL
.027[.69] THICK

SENSOR
MODEL 111A, 112A, 113A SERIES
(NOT SUPPLIED)

MODEL 065A02
SEAL
.015[.38] THICK
(NOT SUPPLIED)

MODEL 065A22
SEAL
.015[.38] THICK

ADAPTOR
1.00[25.4] HEX
1/2-20 UNF-2A THREAD
(SUPPLIED)

MODEL 065A09
SEAL
.06[1.5] THICK
(SUPPLIED)

B

B

A

A

UNLESS OTHERWISE SPECIFIED TOLERANCES ARE:

DIMENSIONS IN INCHES	DIMENSIONS IN MILLIMETERS [IN BRACKETS]
DECIMALS XX ± .01 XXX ± .005	DECIMALS X ± 0.3 XX ± 0.13
ANGLES ± 2 DEGREES	ANGLES ± 2 DEGREES
FILLETS AND RADII .003 - .005	FILLETS AND RADII [0.07 - 0.13]

DRAWN	ECB	1/3/08	MFG	PRR	1/3/08
CHK'D	DM	1/3/08	ENGR	RF	1/3/08
APP'D	NJL	1/3/08	SALES	DPC	1/3/08

TITLE
INSTALLATION DRAWING
MODEL 064B02 FLUSH MOUNTED
WATER COOLED ADAPTOR

PCB PIEZOTRONICS™
3425 WALDEN AVE. DEPEW, NY 14043
(716) 684-0001 E-MAIL: sales@pcb.com

CODE IDENT. NO. 52681	DWG. NO. 7586
SCALE: FULL	SHEET 2 OF 2