

57334

PCB Piezotronics Inc. claims proprietary rights in the information disclosed hereon. Neither it nor any reproduction thereof will be disclosed to others without the written consent of PCB Piezotronics Inc.

REVISIONS		
REV	DESCRIPTION	DIN
E	ROTATE MOUNTING ADAPTOR TO SHOW WIRE HOLES	52548

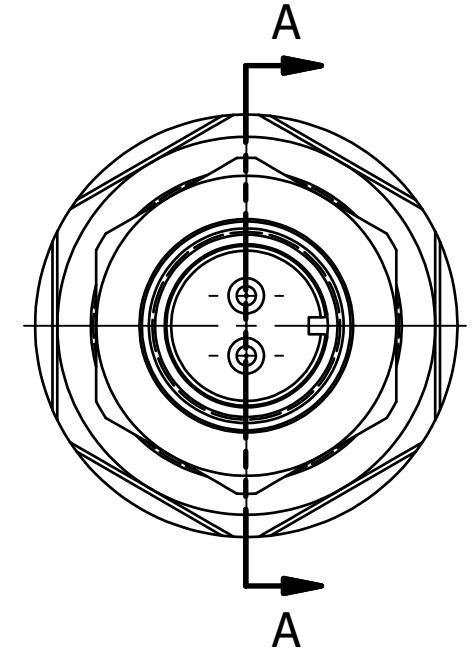
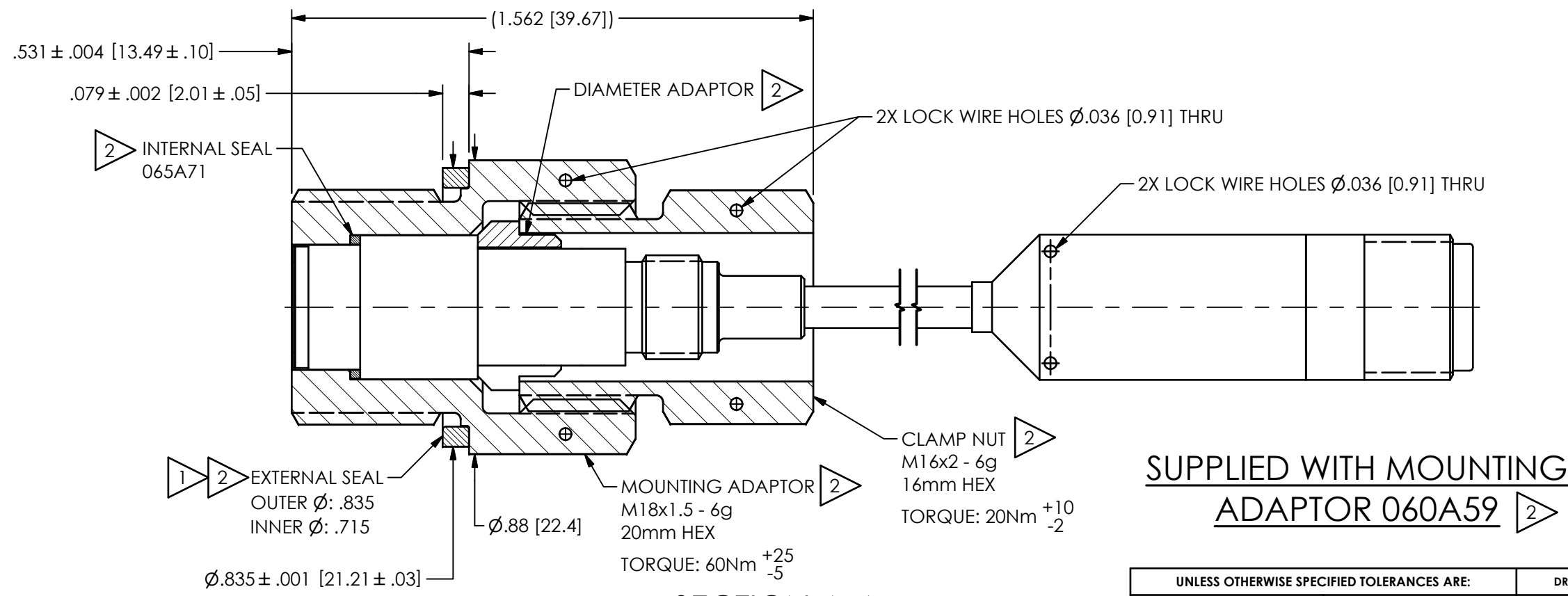
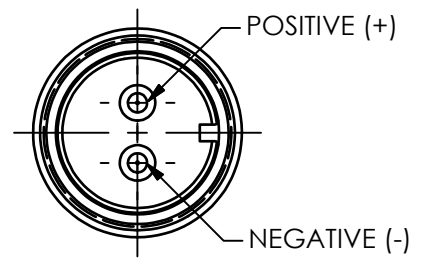
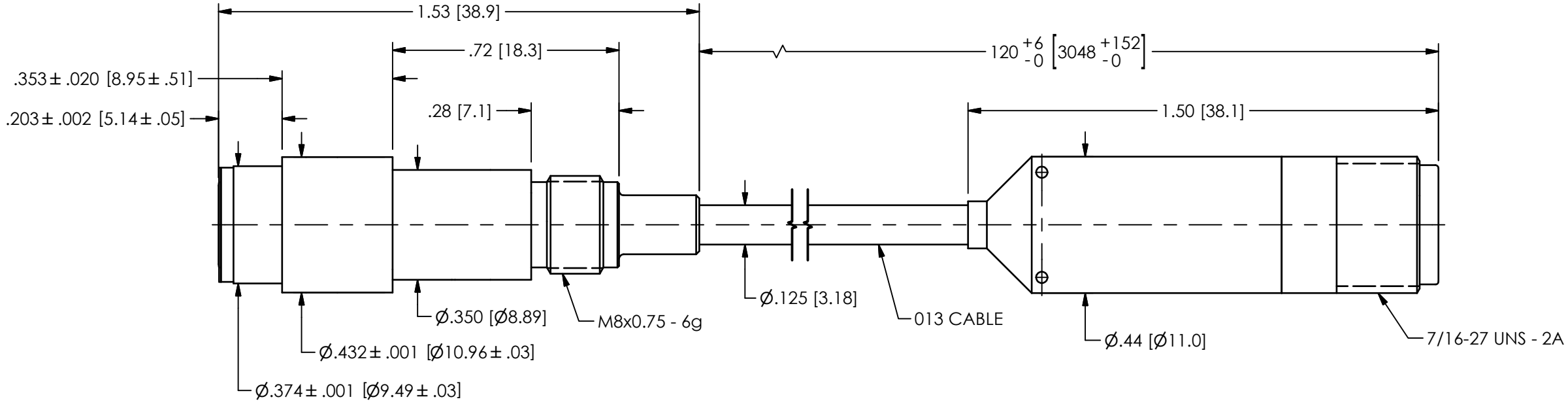

SUPPLIED WITH MOUNTING ADAPTOR 060A59

2 060A59 CONSISTS OF THESE COMPONENTS

1 MATING MACHINE SURFACES TO HAVE A SURFACE FINISH OF Ra 0.8

SECTION A-A

UNLESS OTHERWISE SPECIFIED TOLERANCES ARE:		DRAWN		CHECKED		ENGINEER	
DIMENSIONS IN INCHES	DIMENSIONS IN MILLIMETERS [IN BRACKETS]	KSR	2/9/22	KSR	2/9/22	RF	2/9/22
DECIMALS XX ±.03 XXX ±.010	DECIMALS X ±0.8 XX ±0.25	TITLE OUTLINE DRAWING HIGH TEMPERATURE PRESSURE SENSOR					
ANGLES ± 2 DEGREES	ANGLES ± 2 DEGREES						
FILLETS AND RADII .003 - .005	FILLETS AND RADII 0.07 - 0.13	CODE IDENT. NO. 52681		DWG. NO. 57334		SCALE: 2.5X SHEET 1 OF 1	

PCB PIEZOTRONICS
3425 WALDEN AVE. DEPEW, NY 14043
(716) 684-0001 E-MAIL: sales@pcb.com