

PCB Piezotronics Inc. claims proprietary rights in the information disclosed hereon. Neither it nor any reproduction thereof will be disclosed to others without the written consent of PCB Piezotronics Inc.

REVISIONS		
REV	DESCRIPTION	DIN
B	ADDED NOTE 3	44937

1900

B

B

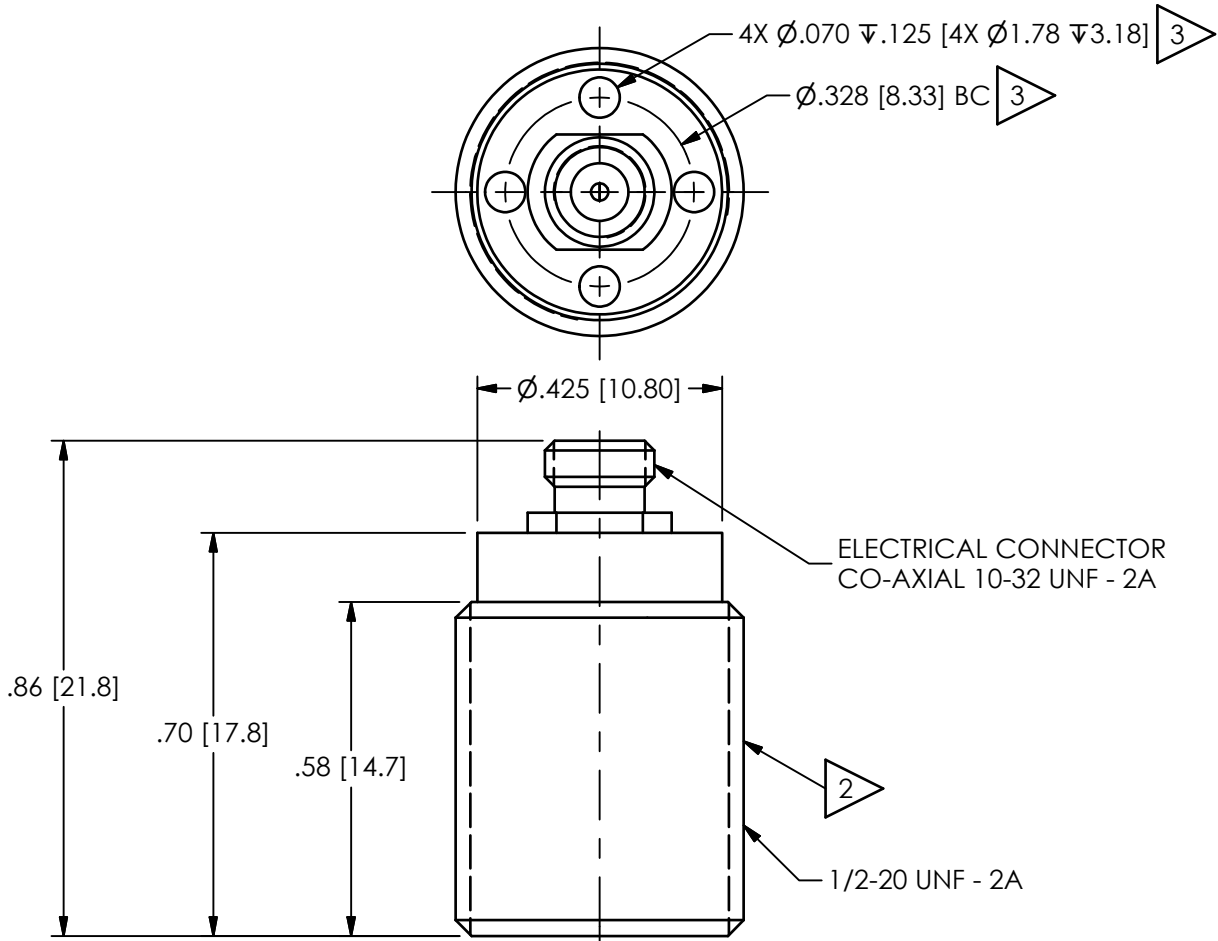

MOUNTING HOLE PREPARATION
 $\varnothing.453$ [11.51] THRU
 $1/2-20$ UNF - 2B THRU

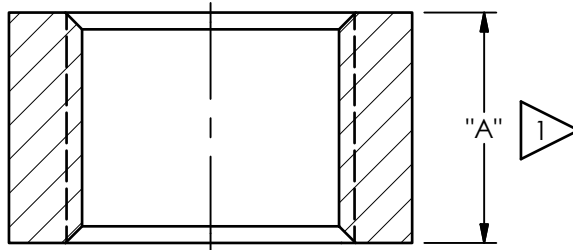

- 3 INSTALL SENSOR USING MODEL 061A30 SPANNER WRENCH (SUPPLIED)
- 2 USE OF PTFE TAPE IS RECOMMENDED WHEN MOUNTING ADAPTOR
- 1 "A" TO SUIT USER REQUIREMENTS

A

A

UNLESS OTHERWISE SPECIFIED TOLERANCES ARE:		DRAWN		CHECKED		ENGINEER		 3425 WALDEN AVE. DEPEW, NY 14043 (716) 684-0001 E-MAIL: sales@pcb.com	
DIMENSIONS IN INCHES	DIMENSIONS IN MILLIMETERS [IN BRACKETS]	BB	1/13/16	ECB	1/13/16	MJK	1/13/16		
DECIMALS XX ± 0.01 XXX ± 0.005	DECIMALS X ± 0.3 XX ± 0.13	TITLE INSTALLATION DRAWING MODEL 132A36 DYNAMIC PRESSURE SENSOR						SCALE: 2X	SHEET 1 OF 1
ANGLES ± 2 DEGREES	ANGLES ± 2 DEGREES							FILLETS AND RADII .003 - .005	FILLETS AND RADII 0.07 - 0.13