



Model 682C05

Platinum Stock Products; Bearing Fault Detector (BFD), DIN rail mount vibration transmitter (for use w/ICP sensor), dual 4-20 mA outputs for overall and peak vibration

Installation and Operating Manual

**For assistance with the operation of this product,
contact the PCB Piezotronics, Inc.**

Toll-free: 800-959-4464

24-hour SensorLine: 716-684-0001

Fax: 716-684-3823

E-mail: imi@pcb.com

Web: www.imi-sensors.com



Model 682C05 Bearing Fault Detector



Operating Guide with Enclosed Warranty Information

3425 Walden Avenue, Depew, New York 14043-2495

Phone (716) 684-0003

Fax (716) 684-3823

Toll Free Line 1-800-959-4IMI

MANUAL NUMBER: 53377
MANUAL REVISION: C
ECN NUMBER: 50130

Table of Contents

<i>Introduction.....</i>	<i>Page 3</i>
<i>General Features</i>	
<i>Installation and Wiring</i>	<i>Page 4</i>
<i>Configuring the 682C05</i>	<i>Page 8</i>
<i>ESD Sensitivity.....</i>	<i>Page 10</i>

Warranty/Service

<i>Warranty, Service & Return Procedure</i>	<i>Page 11</i>
<i>Customer Service.....</i>	<i>Page 12</i>

Introduction

The Model 682C05 is a 4-20mA Din Rail Signal Conditioner designed to interface with IMI Sensor's ICP® accelerometer for bearing fault detection. Specifically, the 682C05 detects high frequency impacts related to bearing fault/lube starvation and provides a 4-20mA signal proportional to the magnitude of vibration. From the same sensor, the device also converts overall vibration to a 4-20mA signal, which is used for traditional machine diagnostics and predictive maintenance such as out of balance and misalignment.

General Features

- Early detection of high frequency impact faults related to bearing failure and lube starvation.
- External transmitters, signal conditioners, and ICP® power supplies can be eliminated by direct connection of the sensor to the Din Rail Signal Conditioner.
- 18Vdc/4mA excitation to power sensor.
- Dual 4-20mA Output Signals for Bearing Fault and Overall Vibration.
- Selectable High Pass filtering for Bearing Fault Detection.
- Overall Output Vibration Ranges include:

Acceleration (g's)	Velocity (in/sec)
5.00	0.50
10.00	1.00
20.00	2.00

- Internal DIP switch selection for Peak or RMS on Overall Vibration.
- Analog output signal connections (RV) for conducting additional frequency analysis.
- Removable Terminal Blocks for easy wiring.
- 35mm (1.38in.) Din Rail Mount configuration.
- Space saving 22.5mm (0.9in.) wide design.

Installation and Wiring

Installation

The Model 682C05 is designed to be mounted on a 35mm Din Rail. Do not install in a harsh area where it can be exposed to cleaning fluids or machine oils. IMI Sensors recommends mounting the 682C05 in a type NEMA 4 enclosure similar to the Model 682A00 to protect the electronics from contamination.

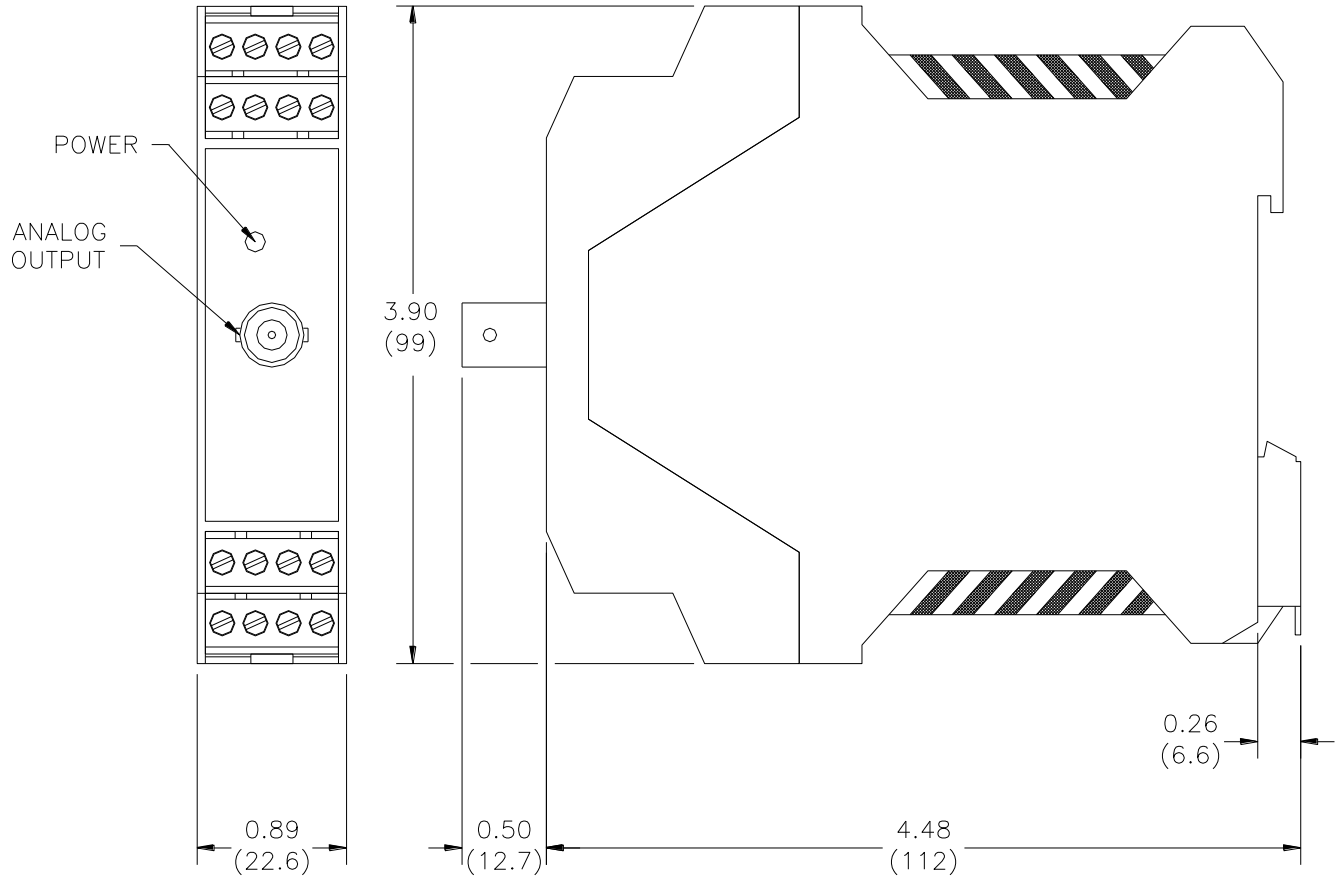

Dimension Drawing

Inch (mm)

Connector and Pinout Diagram

The 682C05 uses plug-in type screw terminal connectors for all input and output connections.

Strip off 8mm of insulation from the connection wire ends. Using a screwdriver, remove the terminal block from the enclosure in either the up or down direction, terminate the wire in the correct location. Do not exceed a torque of 0.5Nm. Re-install the terminal block.

This easy to assemble connection method allows devices to be exchanged easily and the electrical connection to be visibly isolated.

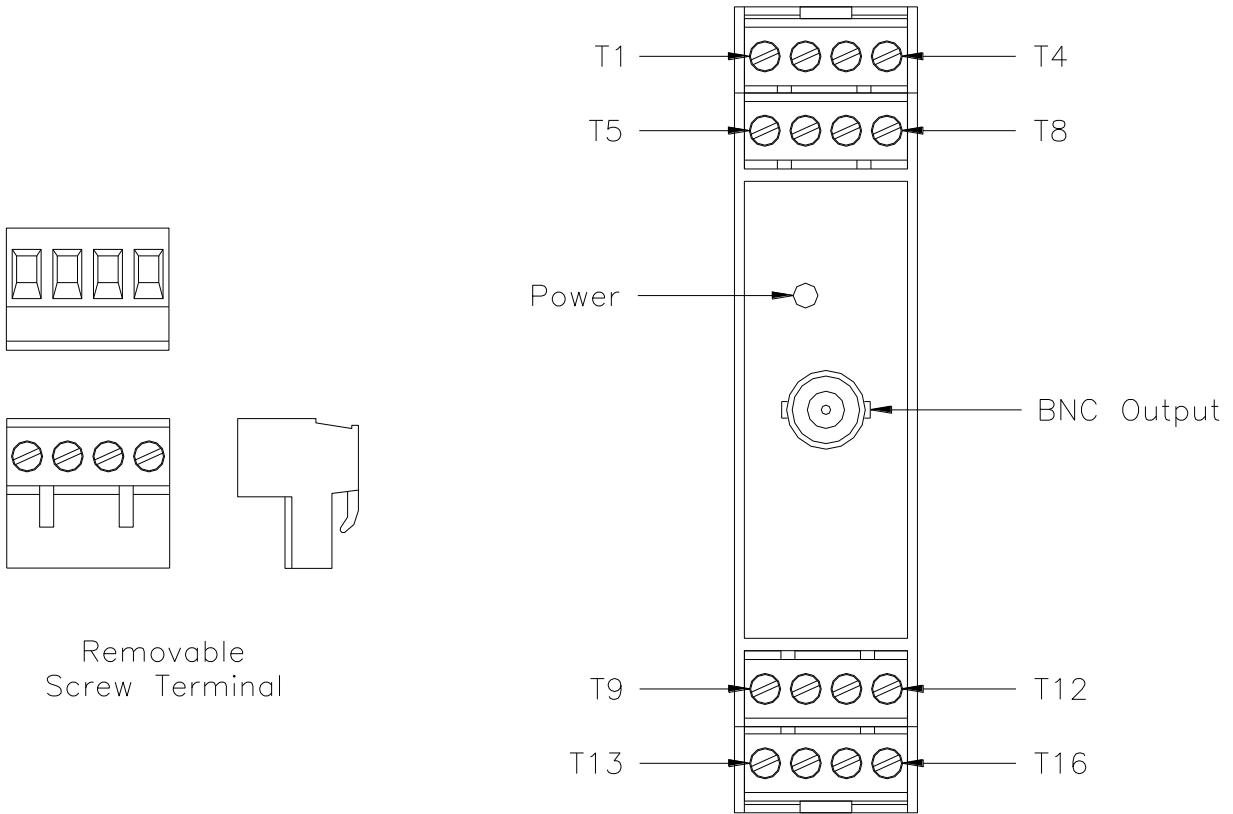

Pin Location Diagram



WARNING

AC and DC input signals and power supply voltages could be hazardous. DO NOT connect live wires to screw terminal plugs, and DO NOT insert, remove, or handle screw terminal plugs with live wires connected.

Pin Descriptions:

DC Power – Pins 1 through 4:

Pin 1 +Power
Pin 2 -Power/Common
Pin 3 Earth Ground
Pin 4 No Connection

ICP® Accelerometer – Pins 5 through 8:

Pin 5 + ICP® Accelerometer
Pin 6 - ICP® Accelerometer
Pin 7 Shield
Pin 8 No Connection

Raw Vibration (RV) – Pins 9 through 12, and BNC Jack:

Pin 9 + RV
Pin 10 - RV
Pin 11 No Connection
Pin 12 No Connection

4 to 20mA Fault Detector Output – Pins 13 & 14:

Pin 13 + 4 to 20mA Fault Output
Pin 14 - 4 to 20mA Fault Output

4 to 20mA Overall Vibration Output – Pins 15 & 16:

Pin 15 + 4 to 20mA Vibration Output
Pin 16 - 4 to 20mA Vibration Output

Notes:

- Pins 3 and 7 are tied together but are NOT tied to the grounding tab on the back of the enclosure.
- Land the accelerometer cable's shield on Pin 7.
- Tie Pin 3 to either din rail ground or Earth ground with the use of an external wire.

Typical Wiring Diagram

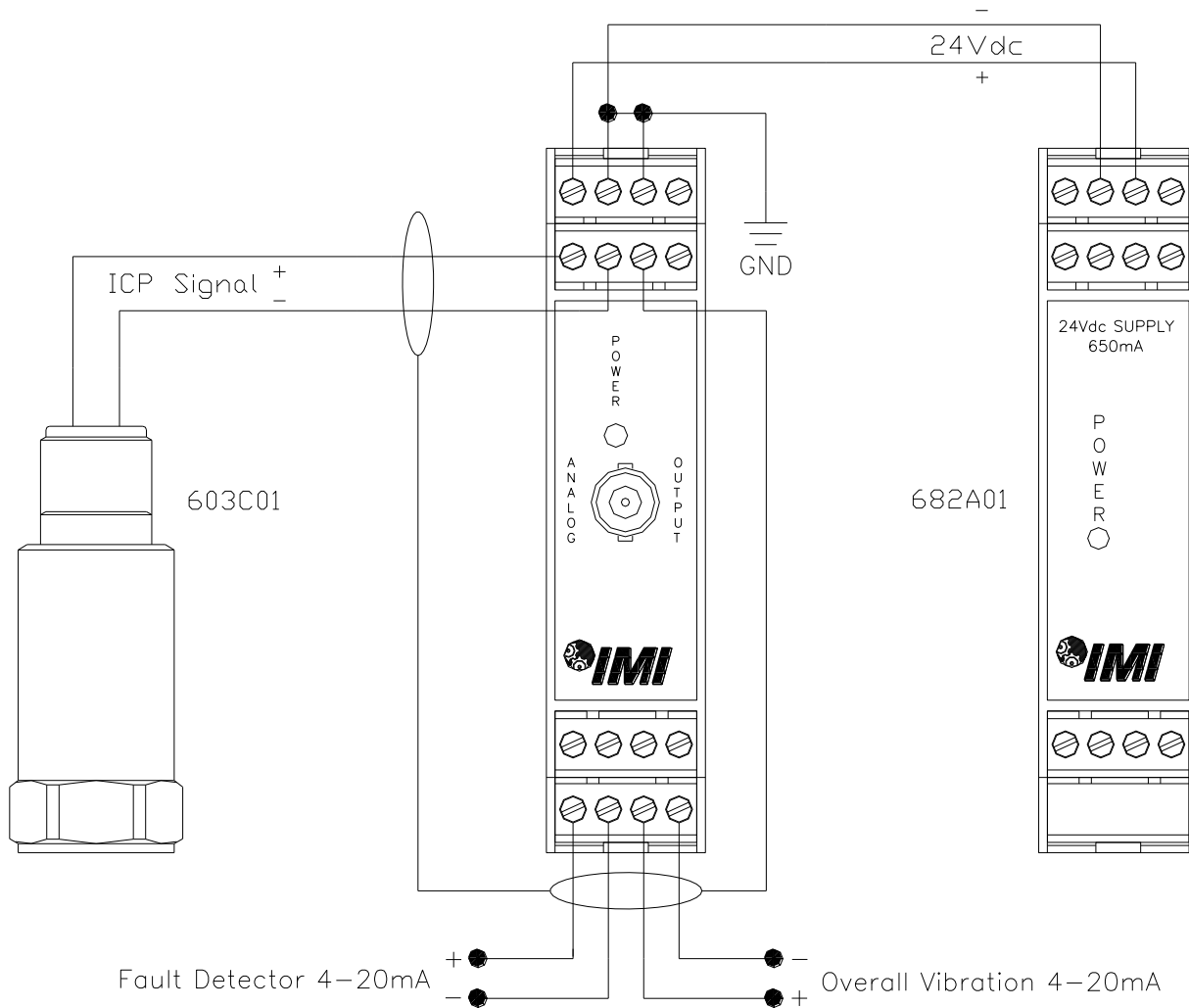

Note: If using the 682A01, mount the 682C05 to the left side of the power supply (as shown) with a recommended minimum separation distance of 4" where applicable.

Configuring the 682C05

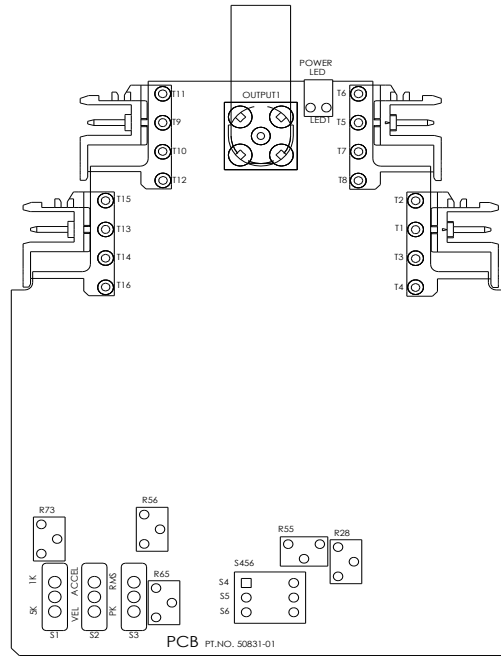

Internal PC Board Diagram

The Internal PC Board Diagram shows the location of the internal DIP and Slide switches. The switches are used to configure the 682C05 for various sensor and vibration ranges.

The PC Board is accessible through the front of the conditioner by removing the Screw Terminal Connectors and disengaging the tabs on the TOP and BOTTOM of the enclosure with a screwdriver. Once disengaged, the PC Board can be slid out for configuration.

DIP Switch and Slide Switch Description:

- S1:** BFD High Pass Filter: 1kHz or 5kHz
- S2:** Overall Vibration Acceleration or Velocity Mode
- S3:** Overall Vibration Peak or RMS Mode
- S4:** Overall: 5g, 0.5ips
- S5:** Overall: 10g, 1ips
- S6:** Overall: 20g, 2ips

Warning: Do not make any adjustments to the internal potentiometers. These potentiometers are used for factory calibration and adjusting them will require return of the 682C05 to the factory for recalibration.

Internal Switch Settings

The internal switches of the Model 682C05 must be configured for the Full Scale Output of the ICP® Sensor connected to it. This is accomplished by removing the front cover and sliding the PC Board out of the Signal Conditioner. Once removed, the switches should be configured per one of the conditions in the following table.

Bearing Fault Detector: Set **S1** for 1kHz or 5kHz (based on running speed). Range is fixed at 50g's Peak.

Overall Vibration:

Range Setting	S2	S3	S4	S5	S6
5g RMS	UP	UP	ON	OFF	OFF
5g Peak	UP	DOWN	ON	OFF	OFF
10g RMS	UP	UP	OFF	ON	OFF
10g Peak	UP	DOWN	OFF	ON	OFF
20g RMS	UP	UP	OFF	OFF	ON
20g Peak	UP	DOWN	OFF	OFF	ON
0.5 in/sec RMS	DOWN	UP	ON	OFF	OFF
0.5 in/sec Peak	DOWN	DOWN	ON	OFF	OFF
1.0 in/sec RMS	DOWN	UP	OFF	ON	OFF
1.0 in/sec Peak	DOWN	DOWN	OFF	ON	OFF
2.0 in/sec RMS	DOWN	UP	OFF	OFF	ON
2.0 in/sec Peak	DOWN	DOWN	OFF	OFF	ON

Note: Factory Default Setting is 1.0in/sec Peak

Recommended Alert and Alarm Settings for Fault Detector:

Although each machine will have alert and alarm settings at various levels based on its high frequency spectra, data has been provided as a baseline to approximate what these limits should be. Note that this data is a recommendation and levels should be adjusted according to measurements taken from a detailed vibration analysis and/or machine history. Please contact IMI Sensors for additional information and support regarding Alert and Alarm settings.

Recommended Fault Detector Alert and Alarm Limits

Speed Range (RPM)	Alert Limit (Peak g-level)	Alarm Limit (Peak g-level)
Less than 5	0.100	0.180
5 - 10	0.150	0.270
10 - 20	0.200	0.360
20 - 60	0.400	0.720
60 - 150	1.000	1.800
150 - 400	2.000	3.600
400 - 700	4.000	7.200
700 - 4000	5.000	9.000
4000 - 10000	7.000	12.600

Warning 1 – ESD sensitivity

The power supply/signal conditioner should not be opened by anyone other than qualified service personnel. This product is intended for use by qualified personnel who recognize shock hazards and are familiar with the safety precautions required to avoid injury.

Warning 2 – ESD sensitivity

This equipment is designed with user safety in mind; however, the protection provided by the equipment may be impaired if the equipment is used in a manner not specified by PCB Piezotronics, Inc.

Caution 1 – ESD sensitivity

Cables can kill your equipment. High voltage electrostatic discharge (ESD) can damage electrical devices. Similar to a capacitor, a cable can hold a charge caused by triboelectric transfer, such as that which occurs in the following:

- *Laying on and moving across a rug,*
- *Any movement through air,*
- *The action of rolling out a cable, and/or*
- *Contact with a non-grounded person.*

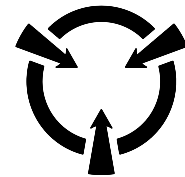

CAUTION
ELECTROSTATIC
DISCHARGE SENSITIVE

The PCB solution for product safety:

- *Connect the cables only with the AC power off.*
- *Temporarily “short” the end of the cable before attaching it to any signal input or output.*

Caution 2 – ESD sensitivity

ESD considerations should be made prior to performing any internal adjustments on the equipment. Any piece of electronic equipment is vulnerable to ESD when opened for adjustments. Internal adjustments should

therefore be done ONLY at an ESD-safe work area. Many products have ESD protection, but the level of protection may be exceeded by extremely high voltage.

Warranty

IMI instrumentation is warranted against defective material and workmanship for 1 year unless otherwise expressly specified. Damage to instruments caused by incorrect power or misapplication, is not covered by warranty. *If there are any questions regarding power, intended application, or general usage, please consult with your local sales contact or distributor.* Batteries and other expendable hardware items are not covered by warranty.

Service

Because of the sophisticated nature of IMI instrumentation, field repair is typically **NOT** recommended and may void any warranty. If factory service is required, return the instrumentation according to the "Return Procedure" stated below. *A repair and/or replacement quotation will be provided prior to servicing at no charge.* Before returning the unit, please consult a factory IMI applications engineer concerning the situation as certain problems can often be corrected with simple on-site procedures.

Return procedure

To expedite returned instrumentation, contact a factory IMI applications engineer for a RETURN MATERIAL AUTHORIZATION (RMA) NUMBER. Please have information available such as model and serial number. Also, to insure efficient service, *provide a written description of the symptoms and problems with the equipment to a local sales representative or distributor, or contact IMI if none are located in your area.*

Customers outside the U.S. should consult their local IMI distributor for information on returning equipment. For exceptions, please contact the International Sales department at IMI to request shipping instructions and an RMA. For assistance, please call (716) 684-0003, or fax us at (716) 684-3823. You may also receive assistance via e-mail at imi@pcb.com or visit our web site at www.pcb.com.



Customer Service

IMI, a division of PCB Piezotronics, guarantees **Total Customer Satisfaction**. If, at any time, for any reason, you are not completely satisfied with any IMI product, IMI will repair, replace, or exchange it at no charge. You may also choose, within the warranty period, to have your purchase price refunded.

IMI offers to all customers, at no charge, 24-hour phone support. This service makes product or application support available to our customers, day or night, seven days a week. When unforeseen problems or emergency situations arise, call the **IMI Hot Line at (716) 684-0003**, and an application specialist will assist you.

3425 Walden Avenue, Depew, NY 14043-2495
Phone: (716) 684-0003 • USA Fax: (716) 684-3823 • INTL Fax: (716) 684-4703

*ICP® is a registered trademark of PCB Group, Incorporated,
which uniquely identifies PCB sensors that incorporate built-in microelectronics.*

Model Number 682C05	BEARING FAULT DETECTOR	Revision: NR ECN #: 46949
-------------------------------	-------------------------------	------------------------------

	<u>ENGLISH</u>	<u>SI</u>	
Performance			
Input Signal	100 mV/g	10.2 mV/(m/s ²)	
Frequency Response(± 3 dB)(Overall Vibration)	10 to 1k Hz	10 to 1k Hz	
Frequency Response(± 3 dB)(Fault)	1k or 5k to 100 kHz	1k or 5k to 100 kHz	[1]
Measurement Range(Fault Detector)	50 g	50 g	
Measurement Range(Vibration)	5/10/20 g	49.0/98.1/196.1 m/s ²	[2]
Measurement Range(Velocity)	0.5/1/2 in/sec	12.7/25.4/50.8 mm/sec	[3]
Output Range	4 to 20 mA	4 to 20 mA	[1][4]
Sampling Time(± 15 %)	7 sec	7 sec	
Span(± 5 %)	16 mA	16 mA	
Control Interface			
Power LED	Green	Green	
Environmental			
Warm Up	<2 minutes	<2 minutes	
Temperature Range(Operating)	32 to 158 °F	0 to 70 °C	
Temperature Range(Storage)	-40 to 257 °F	-40 to 125 °C	
Electrical			
Supply Voltage	20 to 28 VDC	20 to 28 VDC	
Current Consumption	≤ 150 mA	≤ 150 mA	
Excitation Voltage(± 1 V)	24 VDC	24 VDC	
Constant Current Excitation(± 1 mA)	4 mA	4 mA	
Raw Vibration Output	+/-0.01 % of Input	+/-0.01 % of Input	
Load Resistance	500 Ohm	500 Ohm	
Physical			
Size (Width x Height x Depth)	0.9 in x 3.9 in x 4.5 in	22.5 mm x 99 mm x 114.5 mm	
Weight	<5 oz	<142 gm	
Housing Material	Polyamide	Polyamide	
Screw Terminal Wire Size	24-14 AWG	0.2 - 2.5 mm ²	
Electrical Connector(input/output)	Removable Screw Terminals	Removable Screw Terminals	
Electrical Connector(Output, Vibration)	BNC Jack	BNC Jack	
Din Rail Mount	1.38 in	35 mm	

OPTIONAL VERSIONS

Optional versions have identical specifications and accessories as listed for the standard model except where noted below. More than one option may be used.

NOTES:

[1] Internal Dip switch selectable
 [2] Acceleration mode.
 [3] Velocity mode.
 [4] Output current voltage will fluctuate at frequencies below 5 Hz.
 [5] See PCB Declaration of Conformance PS152 for details.

Entered: LK	Engineer: gs	Sales: MC	Approved: BAM	Spec Number:
Date: 6/30/2017	Date: 6/30/2017	Date: 6/30/2017	Date: 6/30/2017	67444



All specifications are at room temperature unless otherwise specified.
 In the interest of constant product improvement, we reserve the right to change specifications without notice.
 ICP® is a registered trademark of PCB Group, Inc.



Phone: 800-959-4464
Fax: 716-684-3823
E-Mail: imi@pcb.com

27894	APPLICATION			REVISIONS				
	NEXT ASS'Y	USED ON	VAR	REV	DESCRIPTION	ECN	DATE	APP'D
				NR	RELEASED TO DRAFTING		10/28/04	DM10/04
				A	REVISED DRAWING TITLE	23034	11/2/05	EB 11/05

PCB Piezotronics Inc. claims proprietary rights in the information disclosed herein. Neither it nor any reproduction thereof will be disclosed to others without written consent of PCB Piezotronics Inc.

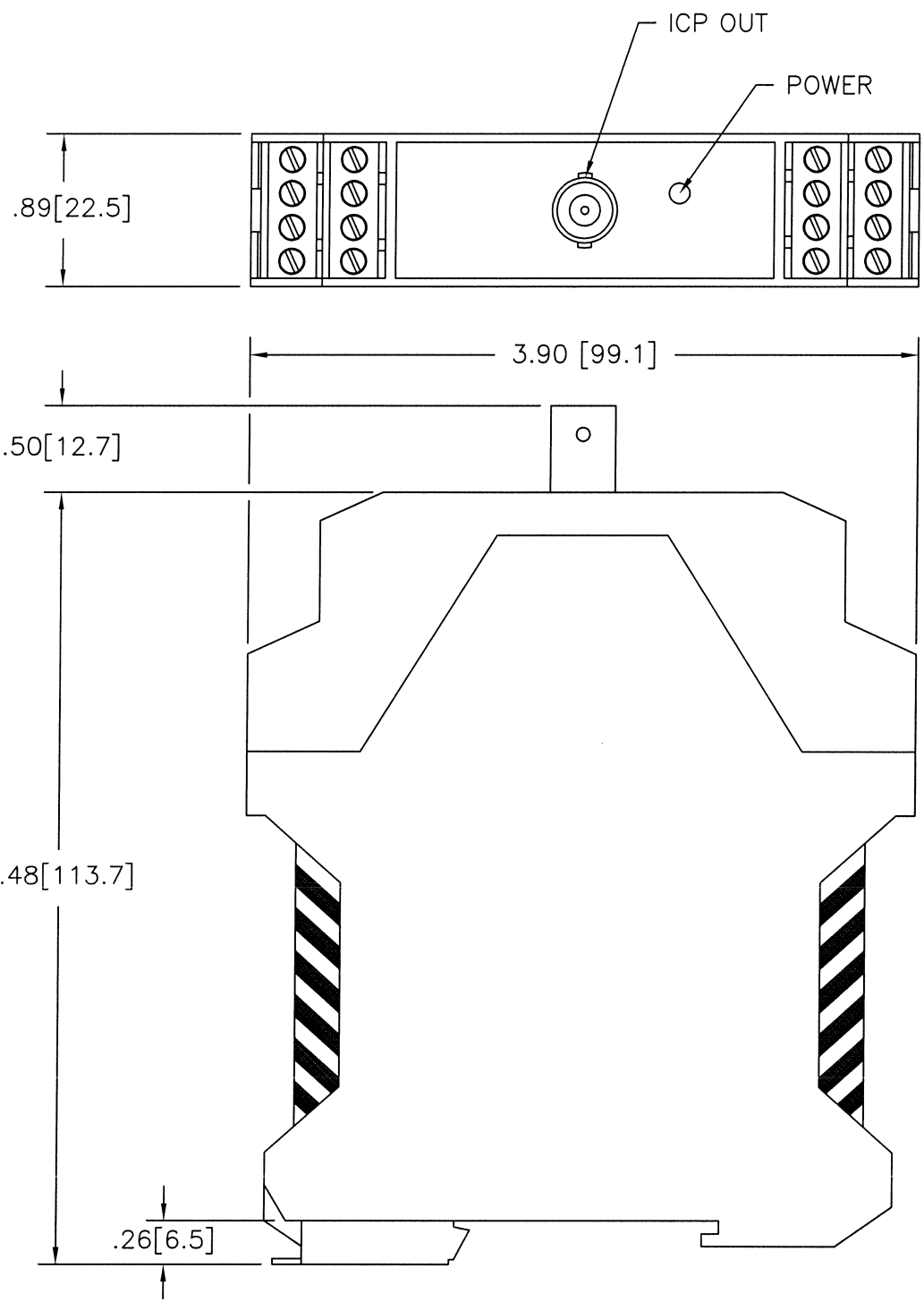

UNLESS SPECIFIED TOLERANCES		DRAWN	PCG 11/3/05	MFG	D.L. 11/4/05	 3425 WALDEN AVE. DEPEW, NY 14043 (716) 684-0001 EMAIL: SALES@PCB.COM
DIMENSIONS IN INCHES	DIMENSIONS IN MILLIMETERS [IN BRACKETS]	CHK'D	ECB 11/3/05	ENGR	MR 11/2/05	
DECIMALS XX ±.03 XXX ±.010	DECIMALS X ±0.8 XX ±0.25	APP'D	N.R. 11/3/05	SALES	EB 11/3/05	
ANGLES ±2 DEGREES	ANGLES ±2 DEGREES	TITLE		CODE IDENT. NO.	DWG. NO.	
FILLET AND RADII .003 - .005	FILLET AND RADII [0.07 - 0.13]	OUTLINE DRAWING BEARING FAULT DETECTOR				27894
DD011 REV. C 01/21/03		SCALE: FULL				SHEET 1 OF 1