



Model 682A14

DIN rail mount vibration transmitter (for use w/ICP sensor), 4-20 mA output for fixed 0-1 ips pk vibration, raw vibration output, fixed 3.5 Hz to 10 kHz frequency range

Installation and Operating Manual

**For assistance with the operation of this product,
contact the PCB Piezotronics, Inc.**

**Toll-free: 800-959-4464
24-hour SensorLine: 716-684-0001
Fax: 716-684-3823
E-mail: imi@pcb.com
Web: www.imi-sensors.com**



Model Number
682A14

4-20 MA DIN RAIL SIGNAL CONDITIONER/TRANSMITTER

Revision: NR
ECN #: 50075

Performance

	ENGLISH	SI	
Channels	1	1	
Input Signal(Vibration)	± 100 mV/g	± 10.2 mV/(m/s ²)	[1]
Output Signal(DC Vibration)	4 to 20 mA	4 to 20 mA	[2]
Output Signal(AC Vibration)	100 mV/g	10.2 mV/(m/s ²)	[3]
Frequency Range(- 3 dB)(Velocity)	210 to 600,000 cpm	3.5 to 10k Hz	[4][5][6]
Output Range(DC Velocity)	0 to 1.00 in/sec pk	0 to 25.4 mm/s pk	[1]

Environmental

Temperature Range(Operating)	-13 to 158 °F	-25 to 70 °C
Temperature Range(Storage)	-40 to 257 °F	-40 to 125 °C
Humidity Range(Non-Condensing)	0 to 95 %	0 to 95 %

Electrical

Power Required	DC Power	DC Power
DC Power	23 to 25 VDC	23 to 25 VDC
DC Power(maximum)	100 mA	100 mA
Settling Time	< 2 min	< 2 min
Excitation Voltage(delivered to sensor)	19 to 21 VDC	19 to 21 VDC
Constant Current Excitation(delivered to sensor)	3 to 5 mA	3 to 5 mA
Output Span(± 5.0 %)(DC Vibration Current Output)	16 mA	16 mA

Physical

Electrical Connector(input/output)	Removable Screw Terminals	Removable Screw Terminals
Electrical Connector (raw vibration output)	BNC Jack	BNC Jack
Housing Material	Polyamide	Polyamide
Size (Height x Width x Depth)	3.9 in x 0.9 in x 4.5 in	99 mm x 22.5 mm x 114.5 mm
Weight(Maximum)	6.4 oz	127
Screw Terminal Wire Size	24-14 AWG	24-14 AWG
Din Rail Mount	1.38 in	35 mm
Status Indicator(Power "on")	Green LED	Green LED
Status Indicator (Input Fault)	Red LED	Red LED

OPTIONAL VERSIONS

Optional versions have identical specifications and accessories as listed for the standard model except where noted below. More than one option may be used.

NOTES:

- [1] Output measurement range is based upon input from 100 mV/g ICP® accelerometer and will be scaled inversely proportional to any percentage deviation of this input.
 [2] Output current voltage will fluctuate at frequencies below 5 Hz.
 [3] Achieved with 100 mV/g ICP® accelerometer input.
 [4] Attenuation is -40 dB/decade.
 [5] The low frequency tolerance is accurate within ± 0.5 Hz of the specified frequency.
 [6] The high frequency tolerance is accurate within ± 1.0 kHz of specified frequency.
 [7] See PCB Declaration of Conformance PS124 for details.



All specifications are at room temperature unless otherwise specified.
 In the interest of constant product improvement, we reserve the right to change specifications without notice.
 ICP® is a registered trademark of PCB Piezotronics, Inc.

Entered: LK	Engineer: gs	Sales: MC	Approved: BAM	Spec Number:
Date: 10/30/2019	Date: 10/30/2019	Date: 10/30/2019	Date: 10/30/2019	72516



Phone: 800-959-4464
 Fax: 716-684-3823
 E-Mail: imi@pcb.com

3425 Walden Avenue, Depew, NY 14043

PCB Piezotronics Inc. claims proprietary rights in the information disclosed hereon. Neither it nor any reproduction thereof will be disclosed to others without the written consent of PCB Piezotronics Inc.

68699

REVISIONS		
REV	DESCRIPTION	DIN
NR	RELEASED TO DRAFTING	48166

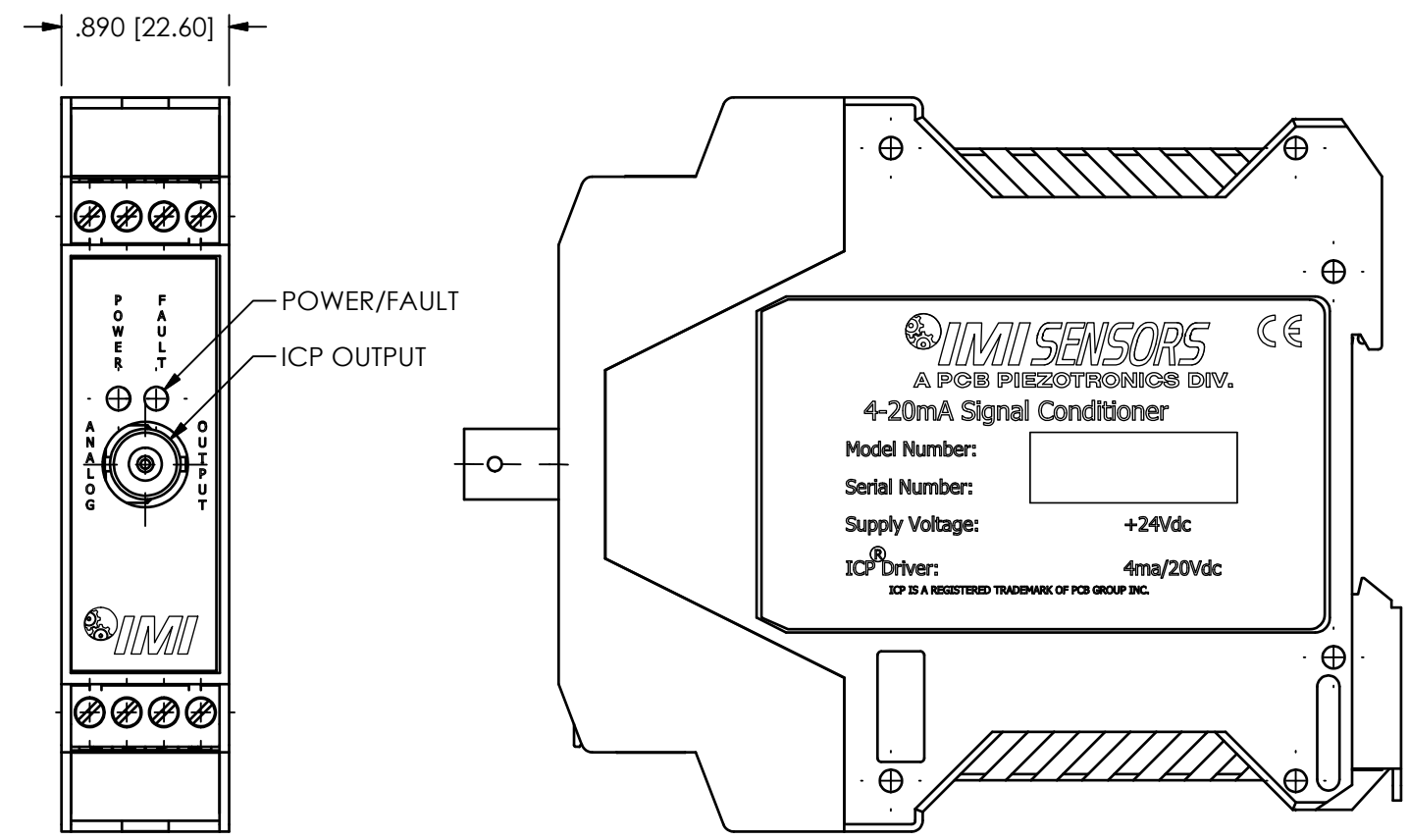
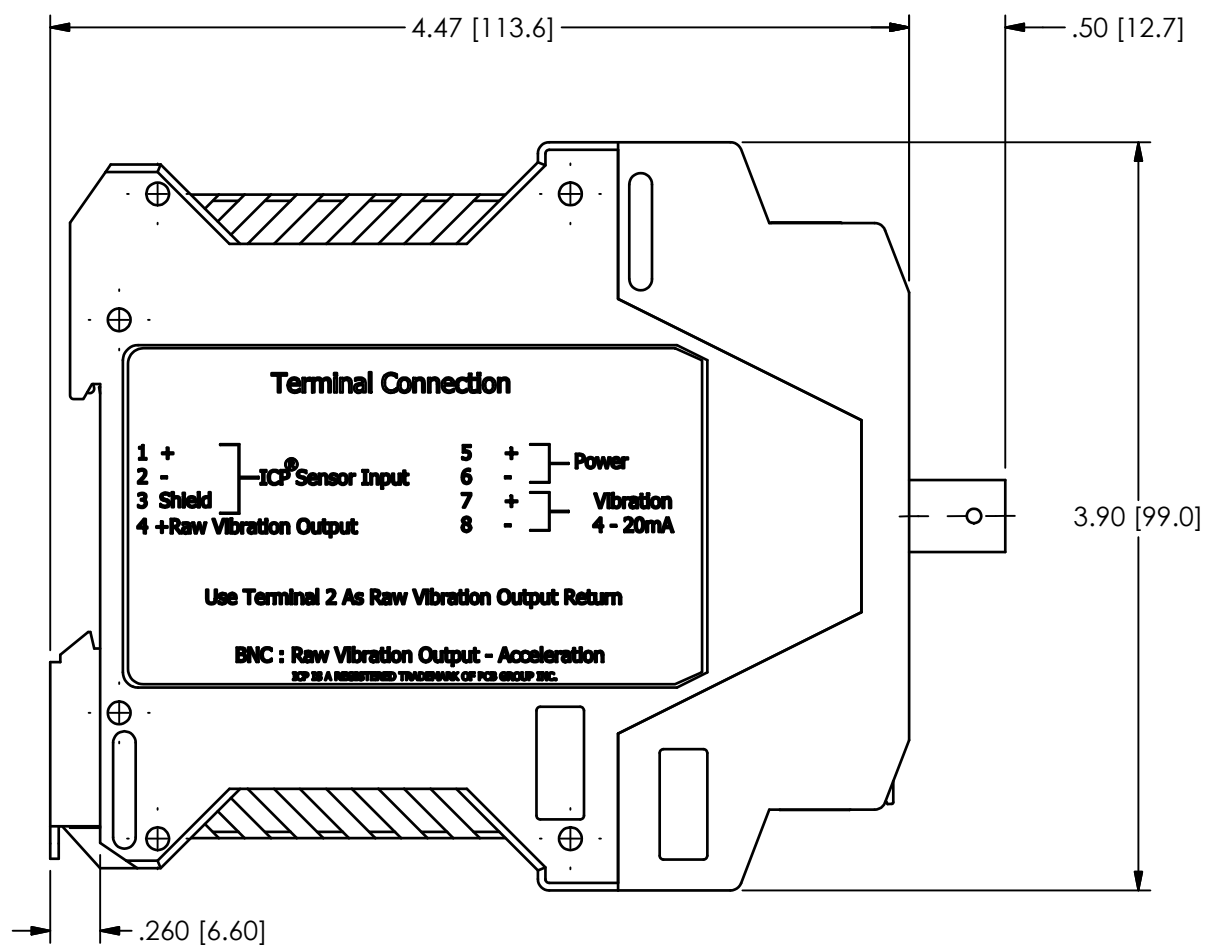

UNLESS OTHERWISE SPECIFIED TOLERANCES ARE:		DRAWN		CHECKED		ENGINEER	
DIMENSIONS IN INCHES	DIMENSIONS IN MILLIMETERS [IN BRACKETS]	KRM	5/23/18	KRM	5/23/18	GGG	5/23/18
DECIMALS XX ±.03 XXX ±.010	DECIMALS X ±0.8 XX ±0.25	TITLE OUTLINE DRAWING 4-20 DIN RAIL CONDITIONER					
ANGLES ± 2 DEGREES	ANGLES ± 2 DEGREES						
FILLETS AND RADII .003 - .005	FILLETS AND RADII 0.07 - 0.13	CODE IDENT. NO. 52681		DWG. NO. 68699		SCALE: FULL SHEET 1 OF 1	

PCB PIEZOTRONICS

3425 WALDEN AVE. DEPEW, NY 14043
(716) 684-0001 E-MAIL: sales@pcb.com

Model 682A14 & 682A15 4-20mA Din Rail ICP[®] Signal Conditioner

CE



Operating Guide with Enclosed Warranty Information

3425 Walden Avenue, Depew, New York 14043-2495

Phone (716) 684-0003

Fax (716) 684-3823

Toll Free Line 1-800-959-4IMI

**MANUAL NUMBER: 72514
MANUAL REVISION: NR
ECN NUMBER: 50075**

Table of Contents

<i>Introduction.....</i>	<i>Page 3</i>
<i> Block Diagram</i>	<i>Page 3</i>
<i> General Features.....</i>	<i>Page 4</i>
<i>Installation and Wiring</i>	<i>Page 5</i>
<i>Configuring the 682A14 & 682A15.....</i>	<i>Page 9</i>
<i>ESD Sensitivity.....</i>	<i>Page 10</i>

Warranty/Serviceing

<i>Warranty, Service & Return Procedure</i>	<i>Page 11</i>
<i>Customer Service.....</i>	<i>Page 12</i>

Introduction

Models 682A14 & 682A15 are 4-20mA din rail signal conditioners designed to interface with a 100 mV/g ICP® accelerometer.

The signal is integrated, filtered and scaled. The 4-20mA output signal is proportional to overall velocity with a measurement range of 0-1 ips rms when using the 682A15 and ips peak when using the 682A14.

Block Diagram

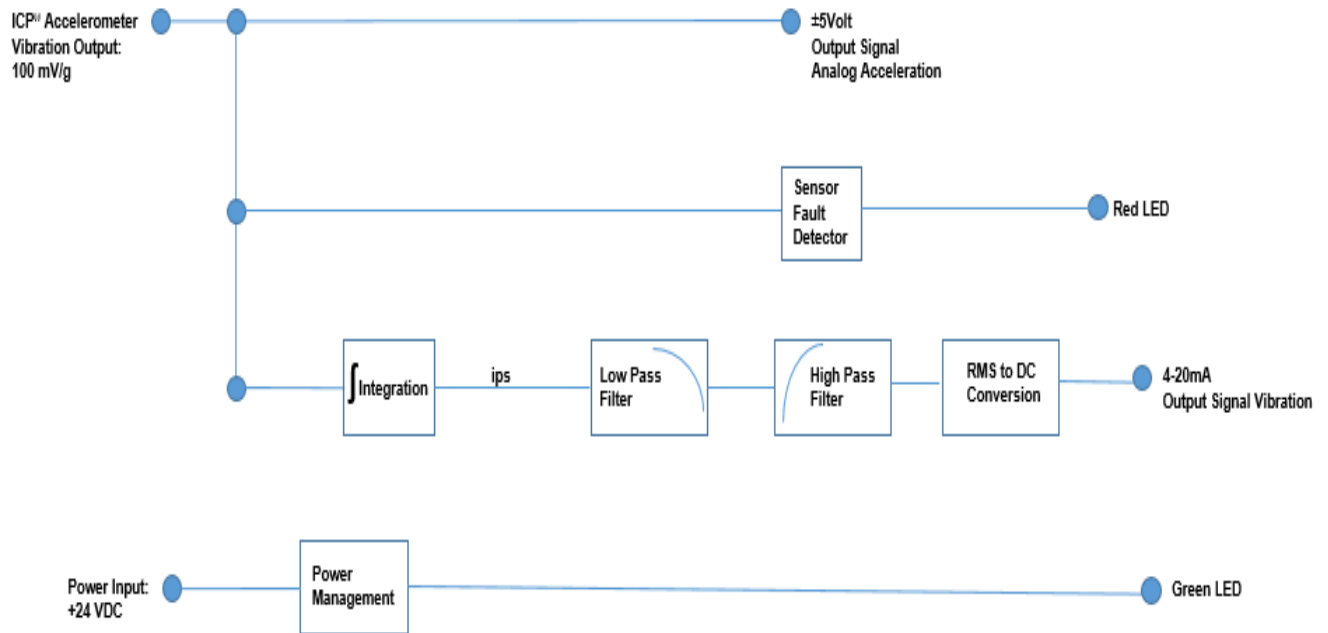

General Features

- External transmitters, signal conditioners and ICP® power supplies can be eliminated by direct connection of the sensor to the din rail signal conditioner.
- 24Vdc unregulated/20Vdc regulated (field-selectable), 4mA excitation to power sensor.
- Current (4-20mA) output signal for long-term process monitoring.
- Analog output (raw vibration) signal for conducting frequency analysis and machinery diagnostics.
- LED indicators for power and sensor fault.
- Removable terminal blocks for easy wiring.
- 35mm (1.38in) din rail mount configuration.
- Space-saving 22.5mm (0.9in.) wide design.

Installation and Wiring

Installation

Models 682A14 & 682A15 are designed to be mounted on a 35mm din rail. Do not install in a harsh area where it can be exposed to cleaning fluids or machine oils. IMI Sensors recommends mounting models 682A14 & 682A15 in a NEMA 4 enclosure, such as Model 682A00, to protect the electronics from contamination.

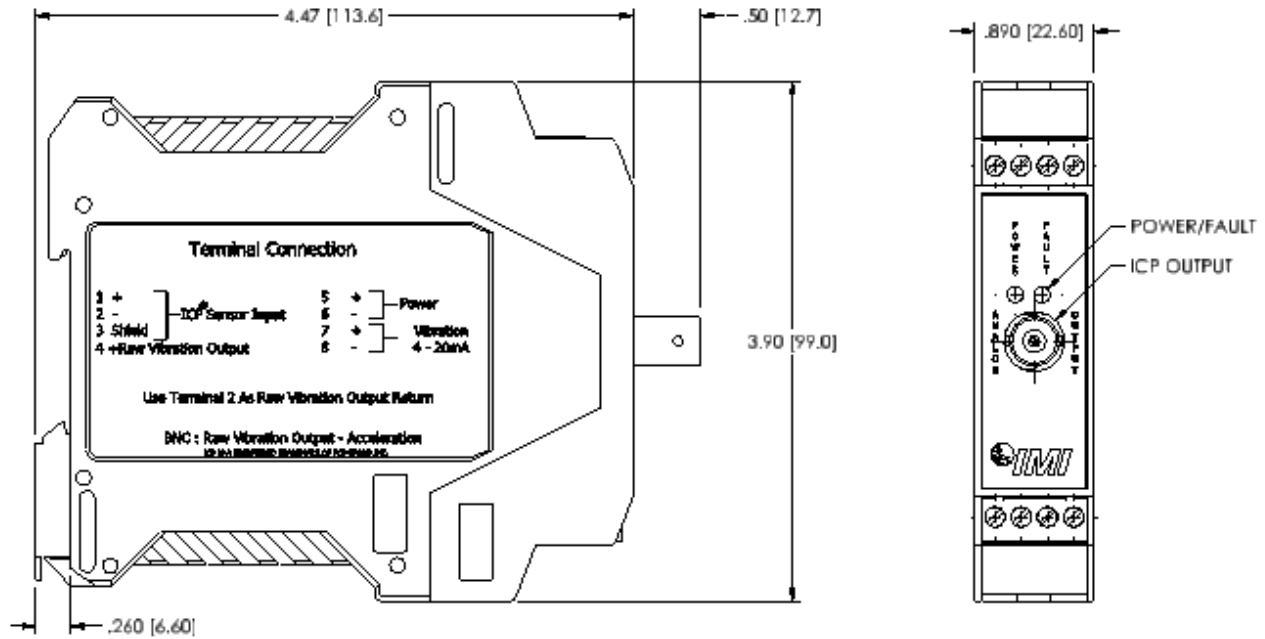

Dimension Drawing

Connector and Pinout Diagram

Models 682A14 & 682A15 use plug-in type screw terminal connectors for all input and output connections. This easy-to-assemble connection method allows devices to be exchanged easily and the electrical connection to be visibly isolated.

Strip off 8mm of insulation from the connection wire ends. Using a flat head screwdriver, remove the terminal block from the enclosure. Loosen the screw, insert the wire connection and tighten the screw. Do not exceed a torque of 0.5 N-m. Re-install the terminal block.

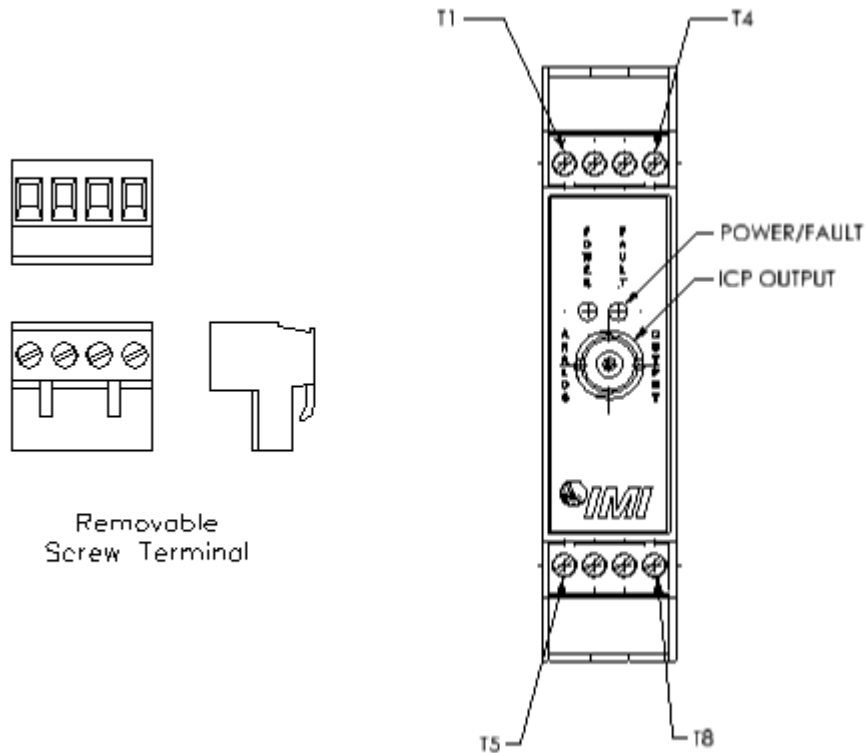

Pin Location Diagram



WARNING

**AC and DC input signals and power supply voltages could be hazardous.
DO NOT connect live wires to screw terminal plugs.
DO NOT insert, remove, or handle screw terminal plugs with live wires connected.**

Pin Descriptions:

DC Power – Pins 5 and 6:

- Pin 5** + Power
- Pin 6** - Power (Common)

ICP® Sensor Input – Pins 1, 2 and 3:

- Pin 1** + ICP® Sensor Input
- Pin 2** - ICP® Sensor Input
- Pin 3** Shield

Analog (Raw Vibration) Output – Pins 2 and 4 or BNC Jack:

- Pin 2** - Raw Vibration
- Pin 4** + Raw Vibration

Current (4 to 20mA) Output – Pins 7 and 8:

- Pin 7** + 4 to 20 mA Vibration
- Pin 8** - 4 to 20 mA Vibration

Notes:

- Pin 3 is tied to the grounding tab on the back of the enclosure.
- Land the accelerometer cable's shield on Pin 3.

Typical Wiring Diagram

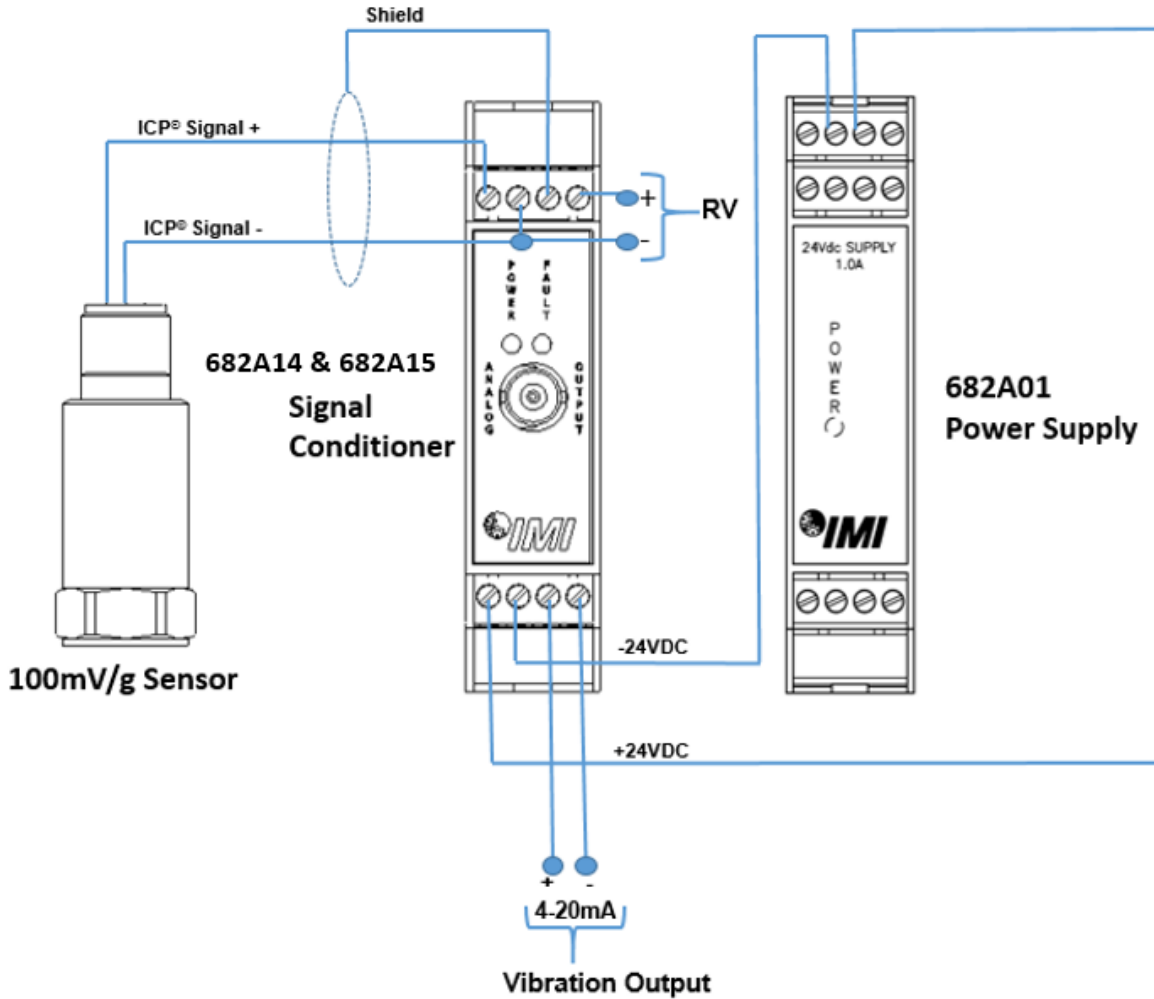

To maintain conformance, Earth Ground, power supply common, input shields and output shields must be connected together.

Configuring the 682A14 & 682A15

Sensor Power Jumper Configuration:

Regulated 20Vdc/4mA Power
(Factory Default)

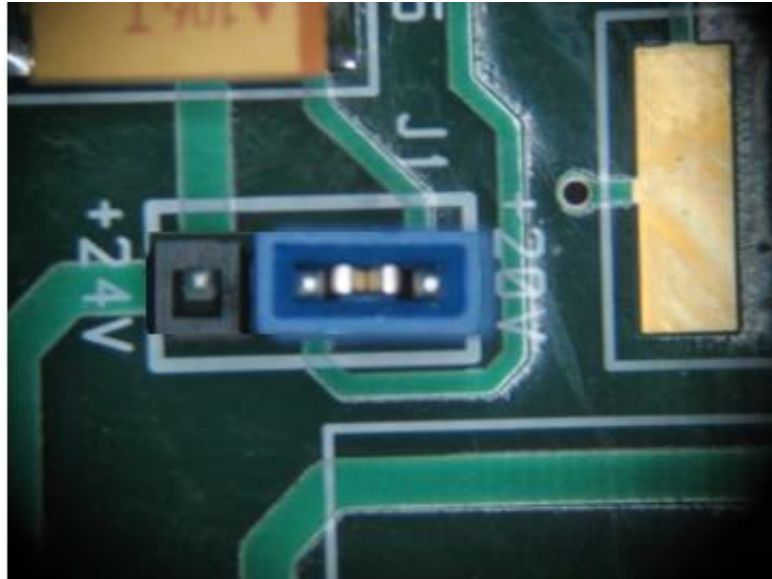

Unregulated 24Vdc/4mA Power
(Constant Current Diode is internal to Model 682A14 & 682A15.)

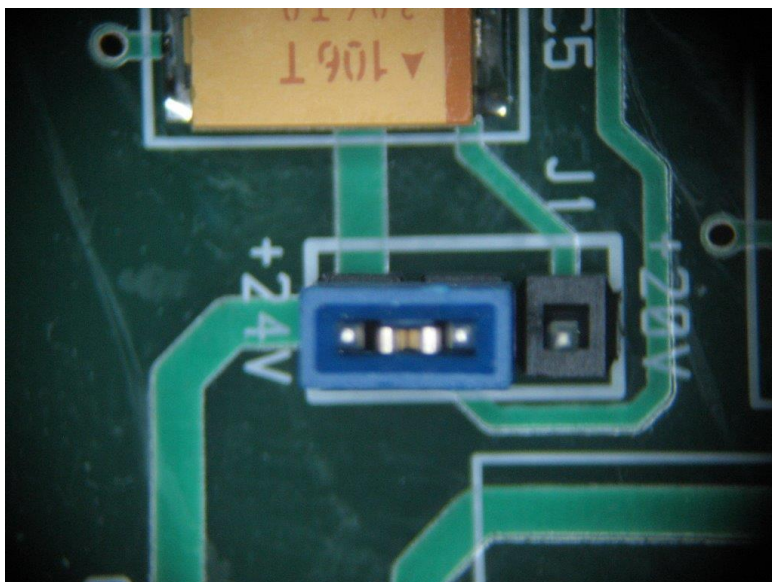

Warning 1 – ESD sensitivity

The power supply/signal conditioner should not be opened by anyone other than qualified service personnel. This product is intended for use by qualified personnel who recognize shock hazards and are familiar with the safety precautions required to avoid injury.

Warning 2 – ESD sensitivity

This equipment is designed with user safety in mind; however, the protection provided by the equipment may be impaired if the equipment is used in a manner not specified by PCB Piezotronics, Inc.

Caution 1 – ESD sensitivity

Cables can kill your equipment. High voltage electrostatic discharge (ESD) can damage electrical devices. Similar to a capacitor, a cable can hold a charge caused by triboelectric transfer, such as that which occurs in the following:

- *Laying on and moving across a rug,*
- *Any movement through air,*
- *The action of rolling out a cable, and/or*
- *Contact with a non-grounded person.*

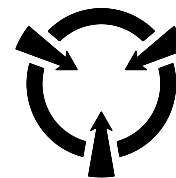

CAUTION
ELECTROSTATIC
DISCHARGE SENSITIVE

The PCB solution for product safety:

- *Connect the cables only with the AC power off.*
- *Temporarily “short” the end of the cable before attaching it to any signal input or output.*

Caution 2 – ESD sensitivity

ESD considerations should be made prior to performing any internal adjustments on the equipment. Any piece of electronic equipment is vulnerable to ESD when opened for adjustments. Internal adjustments should

therefore be done ONLY at an ESD-safe work area. Many products have ESD protection, but the level of protection may be exceeded by extremely high voltage.

Warranty

IMI instrumentation is warranted against defective material and workmanship for 1 year unless otherwise expressly specified. Damage to instruments caused by incorrect power or misapplication, is not covered by warranty. *If there are any questions regarding power, intended application, or general usage, please consult with your local sales contact or distributor.* Batteries and other expendable hardware items are not covered by warranty.

Service

Because of the sophisticated nature of IMI instrumentation, field repair is typically **NOT** recommended and may void any warranty. If factory service is required, return the instrumentation according to the "Return Procedure" stated below. *A repair and/or replacement quotation will be provided prior to servicing at no charge.* Before returning the unit, please consult a factory IMI applications engineer concerning the situation as certain problems can often be corrected with simple on-site procedures.

Return procedure

To expedite returned instrumentation, contact a factory IMI applications engineer for a RETURN MATERIAL AUTHORIZATION (RMA) NUMBER. Please have information available such as model and serial number. Also, to insure efficient service, *provide a written description of the symptoms and problems with the equipment to a local sales representative or distributor, or contact IMI if none are located in your area.*

Customers outside the U.S. should consult their local IMI distributor for information on returning equipment. For exceptions, please contact the International Sales department at IMI to request shipping instructions and an RMA. For assistance, please call (716) 684-0003, or fax us at (716) 684-3823. You may also receive assistance via e-mail at imi@pcb.com or visit our web site at www.pcb.com.



Customer Service

IMI, a division of PCB Piezotronics, guarantees **Total Customer Satisfaction**. If, at any time, for any reason, you are not completely satisfied with any IMI product, IMI will repair, replace, or exchange it at no charge. You may also choose, within the warranty period, to have your purchase price refunded.

IMI offers to all customers, at no charge, 24-hour phone support. This service makes product or application support available to our customers, day or night, seven days a week. When unforeseen problems or emergency situations arise, call the **IMI Hot Line at (716) 684-0003**, and an application specialist will assist you.



3425 Walden Avenue, Depew, NY 14043-2495
Phone: (716) 684-0003 • USA Fax: (716) 684-3823 • INTL Fax: (716) 684-4703

*ICP® is a registered trademark of PCB Group, Incorporated,
which uniquely identifies PCB sensors that incorporate built-in microelectronics.*