

2

1

PCB Piezotronics Inc. claims proprietary rights in the information disclosed hereon. Neither it nor any reproduction thereof will be disclosed to others without the written consent of PCB Piezotronics Inc.

REVISIONS

REV	DESCRIPTION	DIN
NR	RELEASED TO DRAFTING	54702

78683

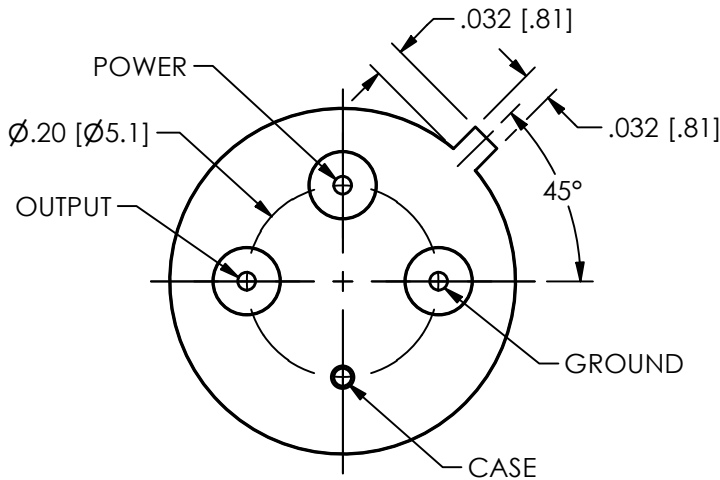
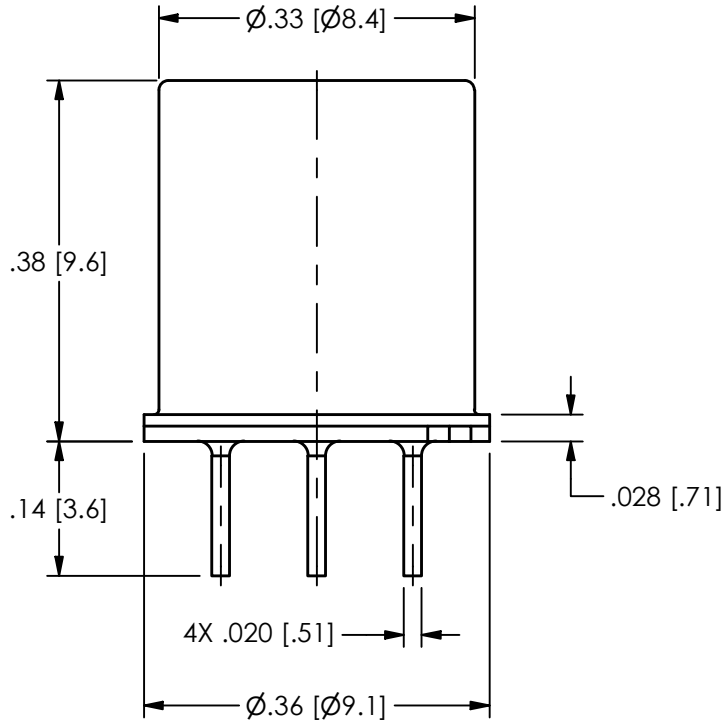

UNLESS OTHERWISE SPECIFIED TOLERANCES ARE:

DRAWN		CHECKED		ENGINEER	
JDM	4/16/24	JDM	4/16/24	LAB	4/16/24

PCB PIEZOTRONICS
AN AMPHENOL COMPANY

3425 WALDEN AVE. DEPEW, NY 14043
(716) 684-0001 E-MAIL: sales@pcb.com

TITLE
 OUTLINE DRAWING
 MODEL 660 SERIES
 LOW POWER 3-WIRE ACCELEROMETER

CODE IDENT. NO.	SIZE	DWG. NO.
52681	A	78683

FILLETS AND RADII	FILLETS AND RADII	SCALE:	SHEET
.003 - .005	0.07 - 0.13	5X	1 OF 1

2

1