

77725

REVISIONS		
REV	DESCRIPTION	DIN
NR	RELEASED TO DRAFTING	53725

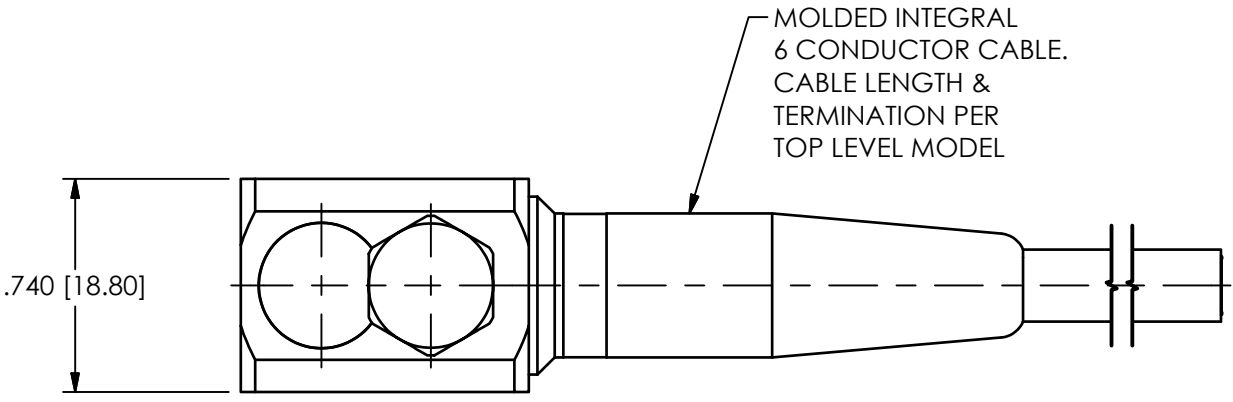

WIRE COLOR REFERENCE	
RED	ACCELERATION
BLACK	GROUND
GREEN	+RTD
WHITE	SENSE +
BLUE	-RTD
BROWN	SENSE -
SHIELD	CABLE GROUND

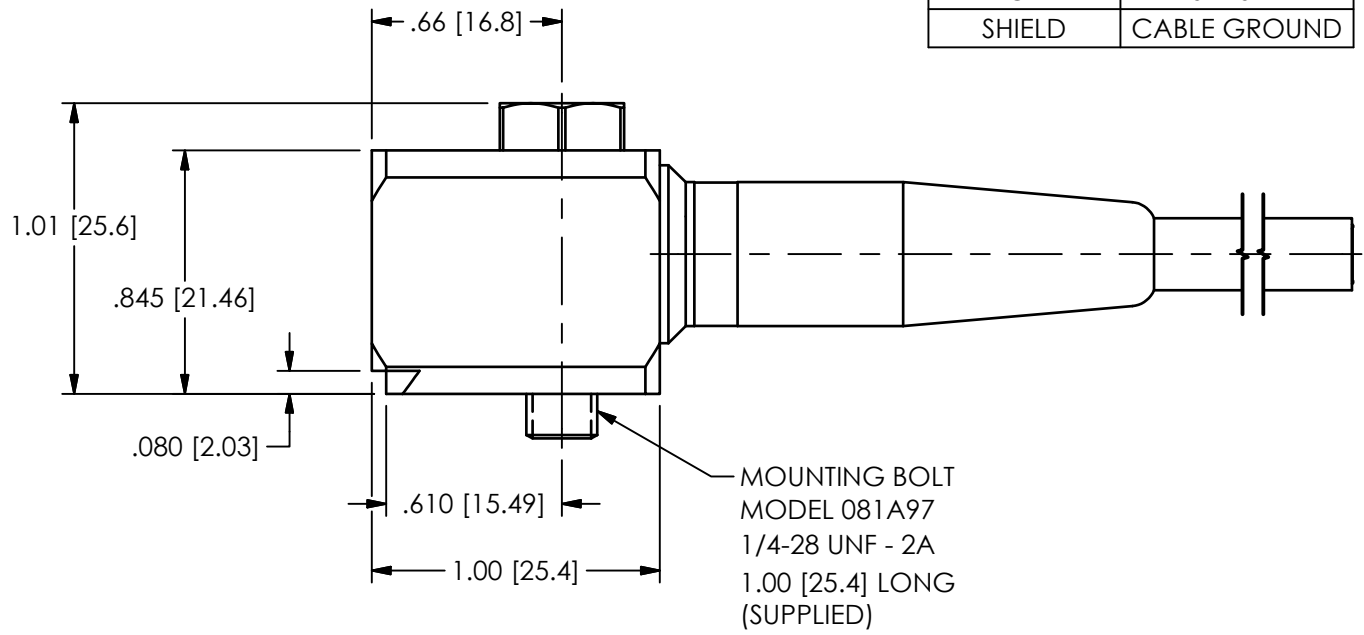

UNLESS OTHERWISE SPECIFIED TOLERANCES ARE:		DRAWN		CHECKED		ENGINEER		<p>835 INNOVATION DRIVE KNOXVILLE, TN 37932-2470 UNITED STATES PHONE: 865-675-2400 WWW.EMERSON.COM/AMS</p>
DIMENSIONS IN INCHES	DIMENSIONS IN MILLIMETERS [IN BRACKETS]	NJF	03/29/23	JJF	03/29/23	GGG	03/29/23	
DECIMALS XX ±.03 XXX ±.010	DECIMALS X ± 0.8 XX ± 0.25	TITLE						
ANGLES ± 2 DEGREES	ANGLES ± 2 DEGREES	OUTLINE DRAWING ACCELEROMETER (M)RTD602D1X SERIES						CODE IDENT. NO.
FILLETS AND RADII .003 - .005	FILLETS AND RADII 0.07 - 0.13							DWG. NO. <b>77725</b>
SCALE: 1.5X							SHEET	1 OF 1