

2

1

PCB Piezotronics Inc. claims proprietary rights in the information disclosed hereon. Neither it nor any reproduction thereof will be disclosed to others without the written consent of PCB Piezotronics Inc.

REVISIONS

REV	DESCRIPTION	DIN
NR	RELEASED TO DRAFTING	43367

59946

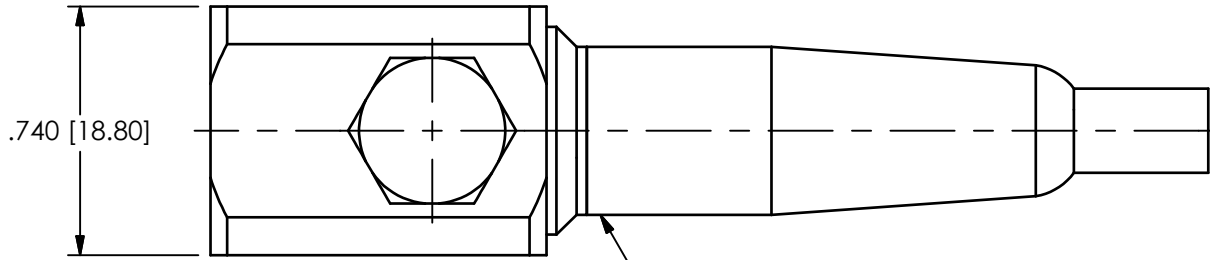

MOLDED INTEGRAL 4 CONDUCTOR CABLE. CABLE LENGTH AND TERMINATION PER TOP LEVEL MODEL.

WIRE COLOR REFERENCE	
RED	ACCELERATION
BLACK	GROUND
GREEN	GROUND
WHITE	TEMPERATURE

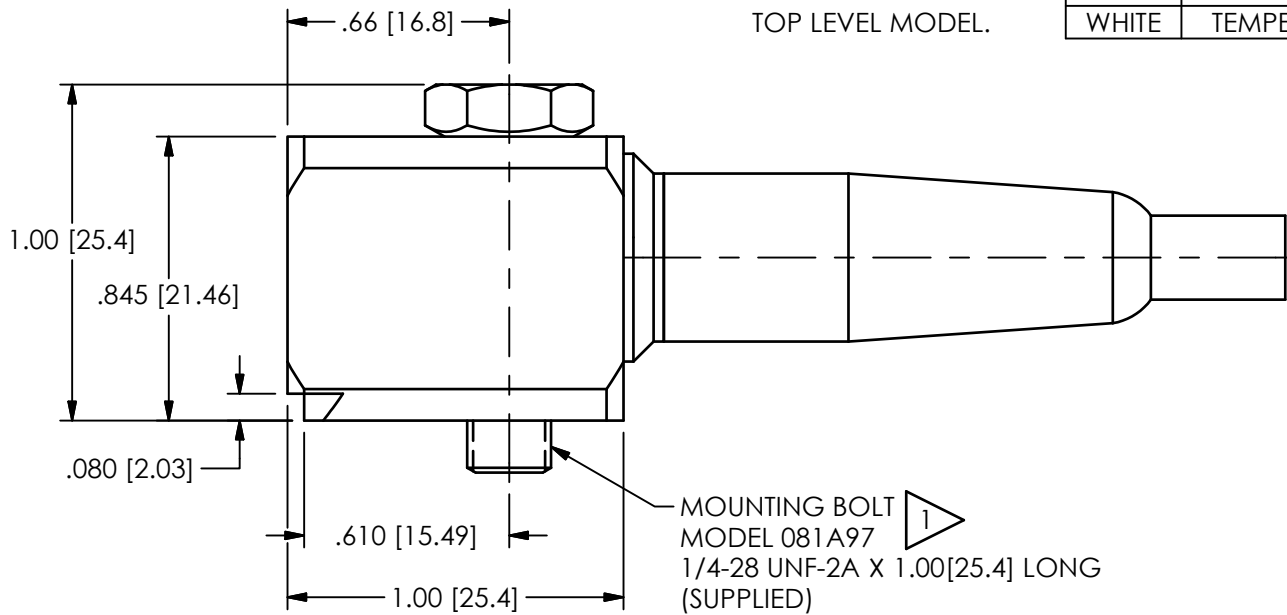

MOUNTING BOLT MODEL 081A97 1/4-28 UNF-2A X 1.00[25.4] LONG (SUPPLIED)

FOR METRIC ACCELEROMETER (MODEL TOM602D11) USE MOUNTING BOLT MODEL M081A97, M6 X 1.00-6g X 1.00[25.4] LONG.

UNLESS OTHERWISE SPECIFIED TOLERANCES ARE:

DRAWN		CHECKED		ENGINEER	
JDM	9/26/14	ECB	9/26/14	GCD	9/26/14



3425 WALDEN AVE. DEPEW, NY 14043 (716) 684-0001 E-MAIL: sales@pcb.com

DIMENSIONS IN INCHES
 DECIMALS XX ±.03
 XXX ±.010
 ANGLES ± 2 DEGREES

DIMENSIONS IN MILLIMETERS [IN BRACKETS]
 DECIMALS X ± 0.8
 XX ± 0.25
 ANGLES ± 2 DEGREES

TITLE
OUTLINE DRAWING
ACCELEROMETER

CODE IDENT. NO. 52681	DWG. NO. 59946
-----------------------	----------------

SCALE: 1.75X SHEET 1 OF 1

2

1

1

jmorawski 14:22 9/26/2014