

78436

PCB Piezotronics Inc. claims proprietary rights in the information disclosed hereon. Neither it nor any reproduction thereof will be disclosed to others without the written consent of PCB Piezotronics Inc.

| REVISIONS |                      |       |
|-----------|----------------------|-------|
| REV       | DESCRIPTION          | DIN   |
| NR        | RELEASED TO DRAFTING | 54286 |

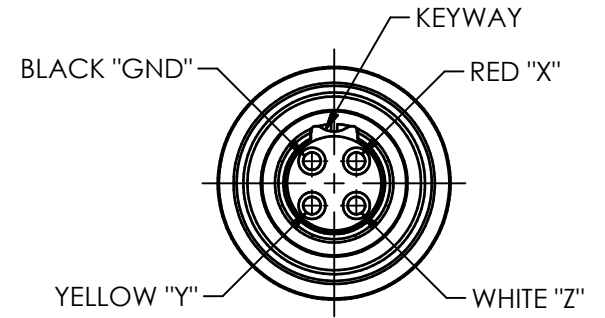

**DETAIL A**  
SCALE 3.5X

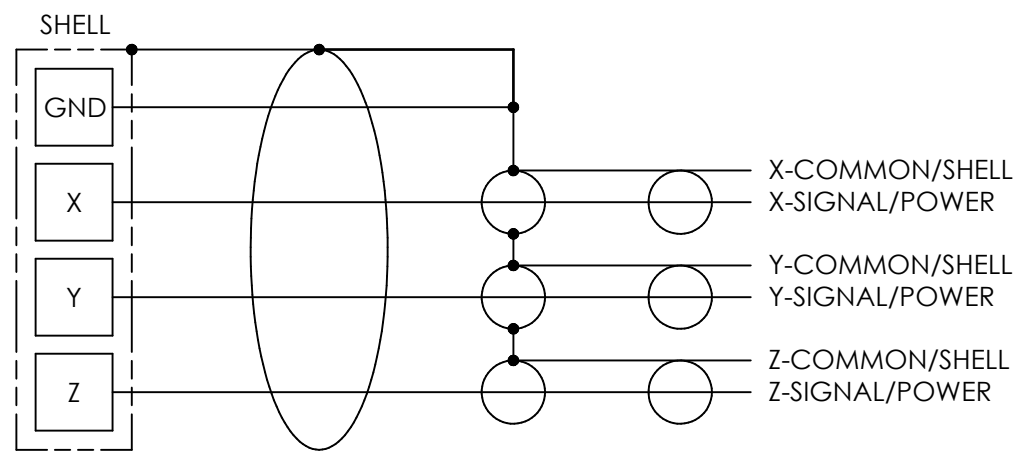
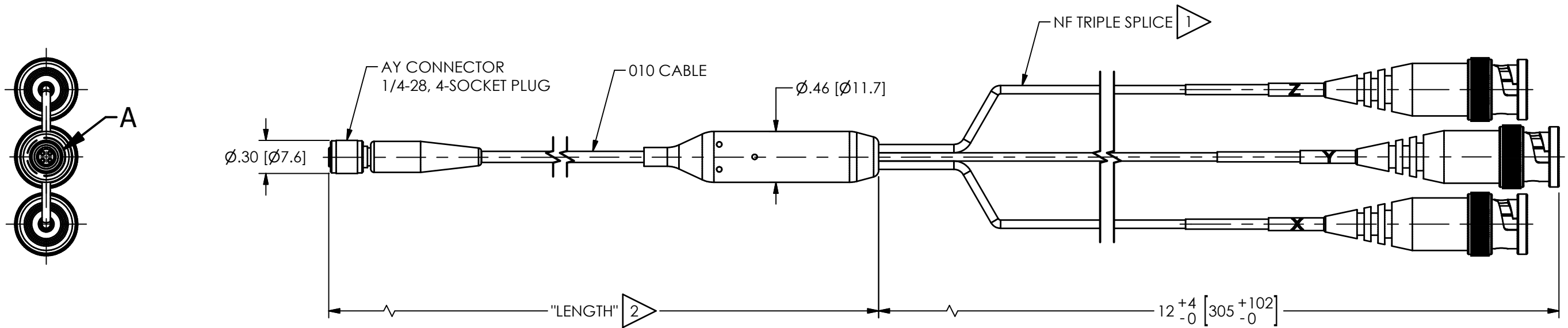

**SCHEMATIC DIAGRAM**

- 2 LENGTH WILL VARY IN FEET OR METERS DEPENDING ON THE MODEL
- 1 CONSISTS OF THREE (3) BLUE 002 COAXIAL CABLES THAT ARE 1'[.3M] LONG AND TERMINATE IN AN AC CONNECTOR (BNC PLUG)

| UNLESS OTHERWISE SPECIFIED TOLERANCES ARE: |  | DRAWN   |          | CHECKED |          | ENGINEER |          |
|--|--|---|----------|---------|----------|----------|----------|
| DIMENSIONS IN INCHES                       |  | JJF   | 10/24/23 | JJF     | 10/24/23 | GCD      | 10/24/23 |
| DECIMALS XX ±.03<br>XXX ±.010              |  | TITLE   |          |         |          |          |          |
| ANGLES ± 2 DEGREES                         |  | OUTLINE DRAWING<br>010TXX CABLE<br>010AYXXXNF CABLE |          |         |          |          |          |
| CABLE TOLERANCES IN ENGLISH                |  | CODE IDENT. NO. 52681                               |          |         |          |          |          |
| CABLE TOLERANCES IN METRIC                 |  | SHEET B   |          |         |          |          |          |
| FILLETES AND RADII .003 - .005             |  | DWG. NO. 78436                                      |          |         |          |          |          |
| FILLETES AND RADII 0.07 - 0.13             |  | SCALE: FULL SHEET 1 OF 1                            |          |         |          |          |          |

**PCB PIEZOTRONICS**  
AN AMPHENOL COMPANY

3425 WALDEN AVE. DEPEW, NY 14043  
(716) 684-0001 E-MAIL: sales@pcb.com