



Model 4115K-09A

TORQUE SENSOR

Installation and Operating Manual

**For assistance with the operation of this product,
contact the PCB Piezotronics, Inc.**

Toll-free: 716-684-0001

24-hour SensorLine: 716-684-0001

Fax: 716-684-0987

E-mail: info@pcb.com

Web: www.pcb.com



Table of Contents

<u>Section</u>	<u>Page</u>
Caution Note	1
1.0 Description	2
2.0 Axis Definition	2
3.0 Mechanical Setup	2
4.0 Electrical Interface	4
5.0 Calibration	4
6.0 Interconnect Cables	5
7.0 Speed Sensors	6
8.0 Routine Maintenance	6
9.0 Troubleshooting	6

MANUAL NUMBER: 18227
MANUAL REVISION: B
ECN NUMBER: 25559

CAUTION!

Personal injury to the operator, as well as damage to equipment, can result if the torque sensor is operated at speeds higher than the maximum or with loads greater than the overload capacity listed on the specification sheet. The operator should be protected from rotating parts by using safety shield guards.

When in doubt about speed ratings or torque capacity, please consult our factory.

1.0 DESCRIPTION

PCB 4100 Series Rotating Transformer Shaft Torque Sensors consist of a specially designed shaft which can be placed between drive and load sources to measure the transfer of power, torque, and speed between them. The torque sensors (**Figure 1**) utilize strain gages on the shaft as the sensing means, and bearings to allow the shaft to turn independent of the housing, which usually remains stationary. Two rotating transformers, one normally mounted on each end of the shaft, allow for excitation and signal transfer between the rotating and non-rotating structures. The strain gages, intimately bonded to the shaft, are connected in a 4-arm Wheatstone Bridge circuit. Wires located on the corners of the bridge are typically connected through the rotary transformer to an MS-type connector on the outside of the housing.



Figure 1 - 4100 Series Rotary Transformer Torque Sensor

An excitation voltage of 3 to 10 VAC RMS at 3.28 kHz is applied to pins B and C of the connector. Torque applied to the shaft causes an imbalance in the strain gage bridge on the shaft, producing an output signal at pins D and A which is linear and exactly proportional to the torque on the shaft.

2.0 AXIS DEFINITION

All PCB torque sensors comply with the Axis and Sense Definitions of NAS-938 (National Aerospace Standard-Machine Axis and Motion) nomenclature and recommendations of the Western Regional Strain Gage committee. The axes are defined in terms of a “right-handed”

orthogonal coordinate system.

The principal axis of a transducer is normally the z-axis. The z-axis will also be the axis of radial symmetry or axis of rotation. In the event there is no clearly defined axis, the following preference system will be used: z, x, y.

Figure 2 shows the axis and sense nomenclature for PCB torque sensors. A positive (+) sign indicates torque in a direction that produces a positive (+) signal voltage and generally defines a clockwise torque. When a 4100 Series Torque Sensor is paired with a current output signal conditioner (e.g. 8120C Series), the clockwise direction corresponds to the 4-20 mA. If both clockwise and counter-clockwise directions are desired, a bipolar current output is required.

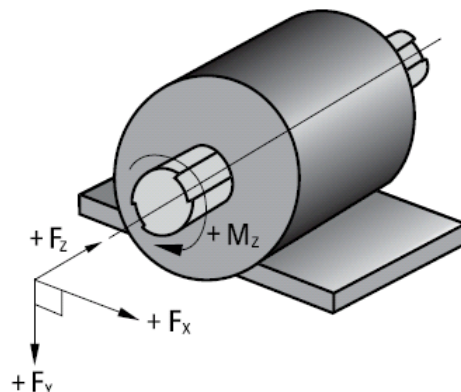

Figure 2 - Axis and Sense Nomenclature for Torque Sensors

3.0 MECHANICAL SETUP

Sensor Orientation

When installing a Model 4100 Series Torque Sensor, consideration should be given to the type of torque to be measured, drive torque or driven torque. The torque sensor should be oriented so that the end of the sensor, that the speed sensor is nearest (Drive End) is placed opposite from the desired measuring point in your system (Driven End).

Floating Mount

(Housing Unsupported or Floating)

When mounted with the housing unsupported, a good quality “Single Flex” coupling should be used on each end of the torque shaft to connect

and support it to the driving and loading devices. Each “Single Flex” coupling will compensate for angular misalignment only. Two “Single Flex” couplings must be used, one

on each end, to compensate for parallel misalignment which can occur in a “Floating Shaft” installation. Reference **Figure 3**.

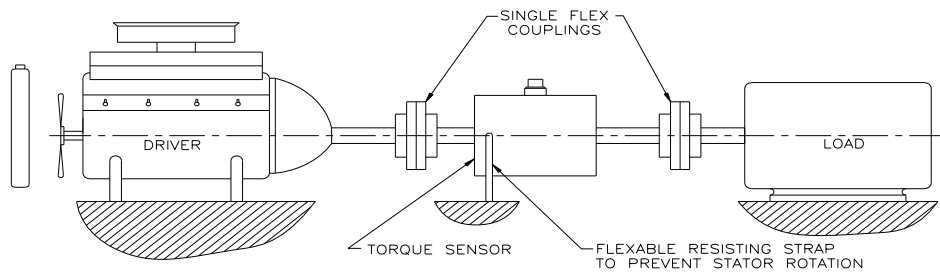

Figure 3 – “Floating” Mount

Some torque sensors in this series are provided with precision ground shaft diameters and double keyways on each end of the shaft. Install a full-length key in each keyway provided. The keys can be made from commercially available key stock and should be precision fitted. Paired keys should have identical lengths. Omission of a key, or different key lengths, can produce rotational unbalance in the shaft and should be avoided.

Shaft supported mounting requires that the housing assembly be restrained from rotating. The housing is provided with a tapped hole on

the side for mounting a restraining strap. The strap should be relatively flexible. Woven wire strap is acceptable.

Fixed Mount (Housing Supported)

When installing a torque sensor with the foot mount option, it is recommended that a “Double Flex” coupling be installed on each end of the torque shaft. Each “Double Flex” coupling will compensate for both angular and parallel misalignment that can occur in a foot mounted application. Reference **Figure 4**.

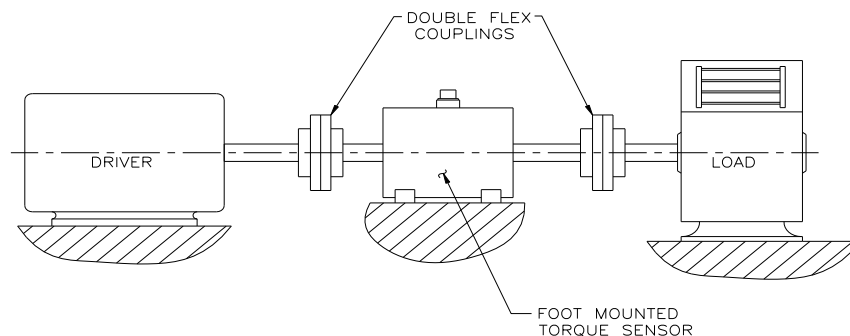

Figure 4 – Fixed Mount

After proper alignment is verified, at least two dowel pin holes should be drilled through the

foot mount plate into the mounting surface below it and dowel pins installed. Installation of

the dowel pins will aid in re-alignment should the torque sensor be removed and re-installed at a later date.

The same coupling precision fitting requirements outlined above also apply here. Foot mounting requires that the torque shaft be aligned as well as possible with the driving and loading devices. Ideally, the alignment should be within 0.001" per inch of shaft diameter. Consult coupling manufacturers for selection of the best couplings for your application.

Note: If you have any question about having a proper installation, please contact the factory for applications assistance.

Flange Mount (Flanged Housing)

Flange mounted torque sensors, in this series, feature precision pilot diameters on the flange ends of the housing to aid in maintaining concentricity of the mounting. Adapter flanges, used in fixturing, should utilize these pilots and be designed with the same accuracy. Careful attention should be given to possible thermal expansion producing end loading on the housing or shaft.

Additional consideration should be made, where possible, in putting thermocouples over each bearing on the housing to monitor bearing temperatures as early warning can usually prevent an impending bearing failure which can produce a catastrophic result.

4.0 ELECTRICAL INTERFACE

Torque sensors in this series typically have an MS3102E-14S-5P receptacle. A mating connector, MS3106F-14S-5S, is also supplied if a cable assembly is not purchased with the sensor. The cable used to connect the torque sensor to the signal conditioner should be a high quality 6-wire shielded type such as Belden 8163. Pin assignments are as follows:

Pin	Function
A	-Signal
B	+Excitation
C	-Excitation
D	+Signal
E	Ground

Recommended excitation voltage is 5 volts AC (RMS) at 3.278 kHz.

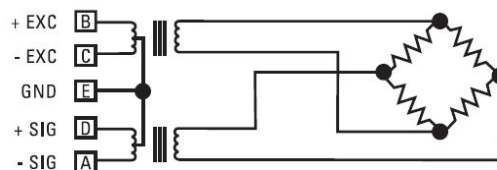

Figure 5 - 4100 Series Sensor Wiring Code

Note: See Page 5 for correct wire and shield connections.

5.0 CALIBRATION

Factory Calibration

Refer to PCB Document #21354

Field Calibration

To maintain high transducer accuracy, the calibration should be rechecked periodically with weights and lever arm. The purpose is not to exactly reproduce the factory calibration, but to look for long term changes in output. If the same lever arm and weights are always used, then precision weights are not required. Just be sure to use your non-precision weights in the same order every time.

Operational Calibration

Once installed in the users mechanical system, the torque sensor needs to be connected through the proper cable to the signal conditioner being used. When this is done and the signal conditioner is connected to the power source and turned on and stabilized (90 minutes is satisfactory), operational calibration can proceed. One end of the torque sensor must be kept disconnected so that "locked-in" torque is not applied to the sensor, which would affect any attempt at system calibration.

6.0 INTERCONNECT CABLES

The length of the interconnect cable between the 4100 Series Torque Sensor and the 8113-105A Reference Module and 8120-400 Series Readout Instrument should not exceed 100 feet. If longer lengths are required, please contact the factory.

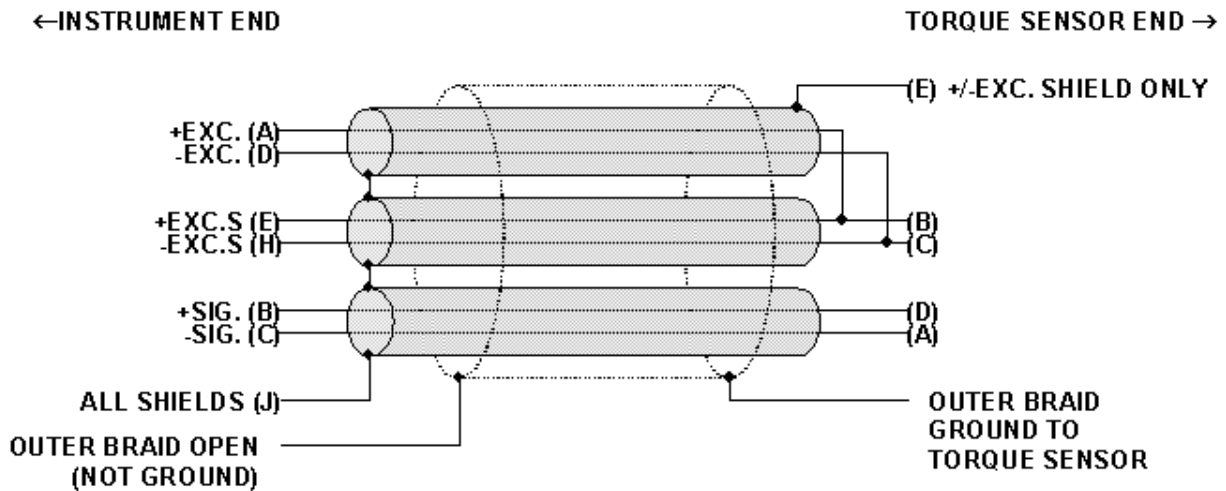

Figure 6 - Model 8310-07 Series Cable Assembly

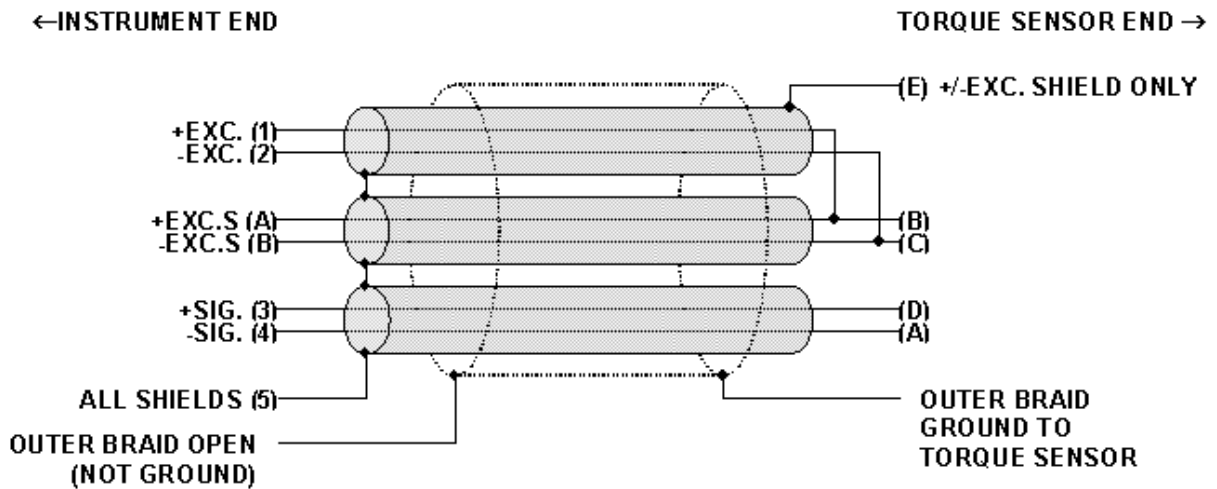

Figure 7 - Model 8310-06 Series Cable Assembly

7.0 SPEED SENSORS

Speed sensors may be used with rotary torque sensors to provide a measurement of rotational speed. Horsepower can then be calculated using the speed and torque measurements by the following relationship:

$$\text{H.P.} = \frac{\text{Torque (in-lbs)} \times \text{R.P.M.}}{63025}$$

Two types of speed sensors are available for use with PCB rotary torque sensors: Passive Magnetic and Active Magnetic.

Passive Magnetic Speed Sensor

These sensors are self-powered units with an AC voltage output that varies in amplitude as the speed of the torque sensor changes. When used with PCB torque sensors, this unit will provide a sine wave output signal (**Figure 10**). Twisted pair shielded cable is recommended. Minimum operation speed is 200 RPM.

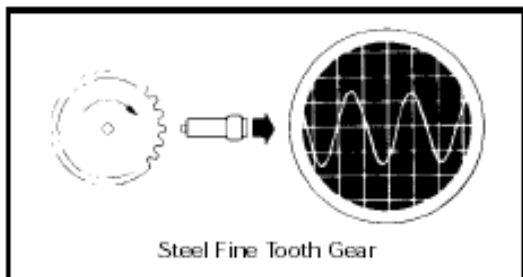

Figure 8 - Speed Sensor Output Signal

Active Magnetic Speed Sensor

This Hall Effect device installs into a port provided on the torque sensor. The output of a speed sensor switches in the presence of ferromagnetic material such as steel gear teeth. Output amplitude and waveform are affected by gear speed and tooth shape.

Speed sensor gears are usually made with 60 teeth. A speed sensor used with a 60-tooth gear will have an output of 100 Hz for a shaft speed of 100 RPM.

Installation

Most standard PCB torque sensors are furnished with a 60-tooth integral counter gear with a 5/8-18 threaded port in the top side of the housing.

To install the speed sensor:

- 1) First remove the shipping plug and o-ring from the housing.
- 2) Ensure the sensor is not rotating. Gently thread the speed sensor into the housing until it touches the integral counter gear.
- 3) Back the speed sensor out ¼ turn, noting the position of the marking on the speed sensor.*
- 4) Turn the speed sensor clockwise or counter-clockwise whichever is closer, so that the flat is perpendicular to the torque sensor housing. Lock it in place with the two jam nuts provided.

* Proper orientation of the speed sensor tip, relative to the gear movement, is required. Reference the speed gear specification sheet for orientation information

8.0 ROUTINE MAINTENANCE

Field maintenance is not required. All service maintenance on the Torque Sensor is done at the factory.

9.0 TROUBLESHOOTING

- ✓ Check all connections to the torque sensor and readout instrument.
- ✓ Check the interconnect cable for proper termination and possible damage.
- ✓ Verify the excitation and output resistances of the torque sensor match the calibration sheet. Do not apply more than our recommended voltage to the torque sensor circuit.
- ✓ Verify that the bearings are running at normal temperatures. See Mechanical Setup on Page 2.

	<u>ENGLISH</u>	<u>SI</u>	
Performance			
Measurement Range(Full Scale Capacity)	2400 in-lb	270 Nm	[1]
Sensitivity(± 15 %)(output at rated capacity)	2.5 mV/V	2.5 mV/V	[1][3]
Non-Linearity	≤ 0.05 % FS	≤ 0.05 % FS	[3]
Hysteresis	≤ 0.05 % FS	≤ 0.05 % FS	[3]
Non-Repeatability	≤ 0.03 % FS	≤ 0.03 % FS	[3]
Environmental			
Overload Limit	7200 in-lb	815 Nm	
Temperature Range(Operating)	-65 to 285 °F	-54 to 141 °C	
Temperature Range(Compensated)	+70 to +170 °F	+21 to 77 °C	
Temperature Effect on Output(Maximum)	± 0.002 %Reading/°F	± 0.0036 %Reading/°C	[4]
Temperature Effect on Zero Balance(Maximum)	± 0.002 %FS/°F	± 0.0036 %FS/°C	[4][3]
Electrical			
Bridge Resistance	350 Ohm	350 Ohm	[1]
Excitation Frequency	3.28 kHz	3.28 kHz	
Excitation Voltage	2 to 10 VAC rms	2 to 10 VAC rms	[2]
Insulation Resistance	>5,000,000 kohm	>5,000,000 kohm	
Zero Balance	≤ 2 % FS	≤ 2 % FS	[3]
Bridge Current(at 5 VAC)	50 mA	50 mA	
Physical			
Size (Shaft Length x Housing Length x Housing Height)	9.56 in x 8.25 in x 6.00 in	242.82 mm x 209.55 mm x 152.40 mm	
Weight	47 lb	21.3 kg	
Mounting	Splined	Splined	
Sensing Element	Strain Gage	Strain Gage	
Housing Material	Black Oxided Steel	Black Oxided Steel	
Shaft Material	Steel	Steel	
Electrical Connector	MS3102A-14S-5P	MS3102A-14S-5P	
Electrical Connection Position	Side	Side	
Torsional Stiffness	380,000 in-lb/radian	42,900 N-m/radian	
Rotating Inertia	0.0055 in-lb sec ²	0.0006 N-m sec ²	
Maximum Speed	15,000 RPM	15,000 RPM	

OPTIONAL VERSIONS

Optional versions have identical specifications and accessories as listed for the standard model except where noted below. More than one option may be used.

NOTES:

[1]Nominal.
 [2]Recommended 10 VAC RMS.
 [3]FS - Full Scale.
 [4]Over compensated operating temperature range.
 [5]See PCB Declaration of Conformance PS062 for details.

SUPPLIED ACCESSORIES:

Model 180-019A 5-socket mating connector for Series 3100, 4100, 4200 torque sensors
 Model 8113-105A Relay activated precision shunt calibration module

Entered: AP	Engineer: PE	Sales: KWW	Approved: JSD	Spec Number:
Date: 2/12/2015	Date: 2/12/2015	Date: 2/12/2015	Date: 2/12/2015	18489



PCB Load & Torque, Inc.
24350 Indoplex Circle
Farmington Hills, MI 48335
UNITED STATES
Phone: 866-684-7107
Fax: 716-684-0987
E-Mail: Itinfo@pcbloadtorque.com
Web site:
<http://www.pcbloadtorque.com>



*All specifications are at room temperature unless otherwise specified.
 In the interest of constant product improvement, we reserve the right to change specifications without notice.*

PCB Load & Torque (A Division of PCB Piezotronics, Inc.) claims proprietary rights in the information disclosed hereon. Neither it nor any reproduction thereof will be disclosed to others without the written consent of PCB Load and Torque.

22675

REVISIONS		
REV	DESCRIPTION	ECO
A	ADDED VIBRATION MONITORING HOLES - 06.02.22, PTE	45389

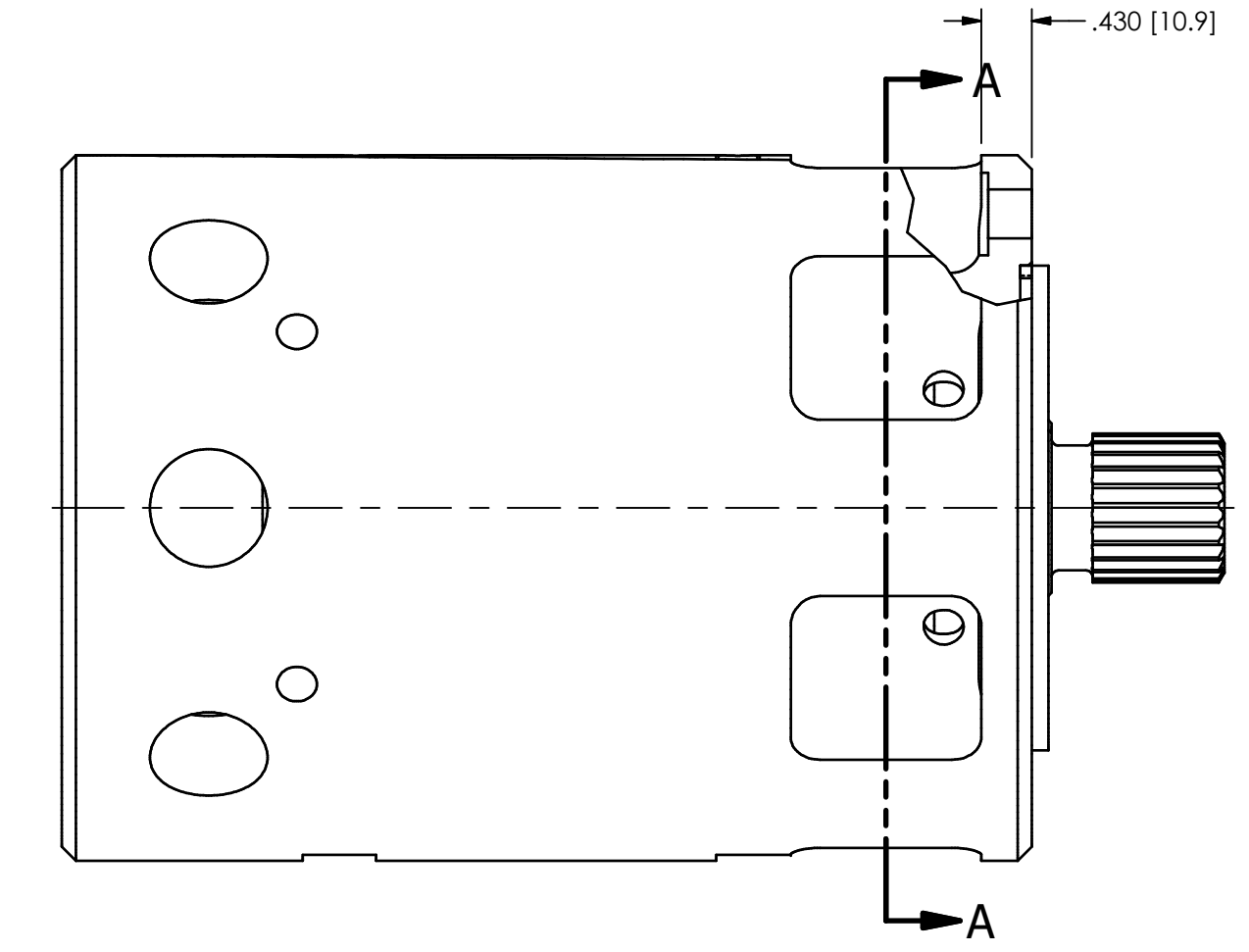
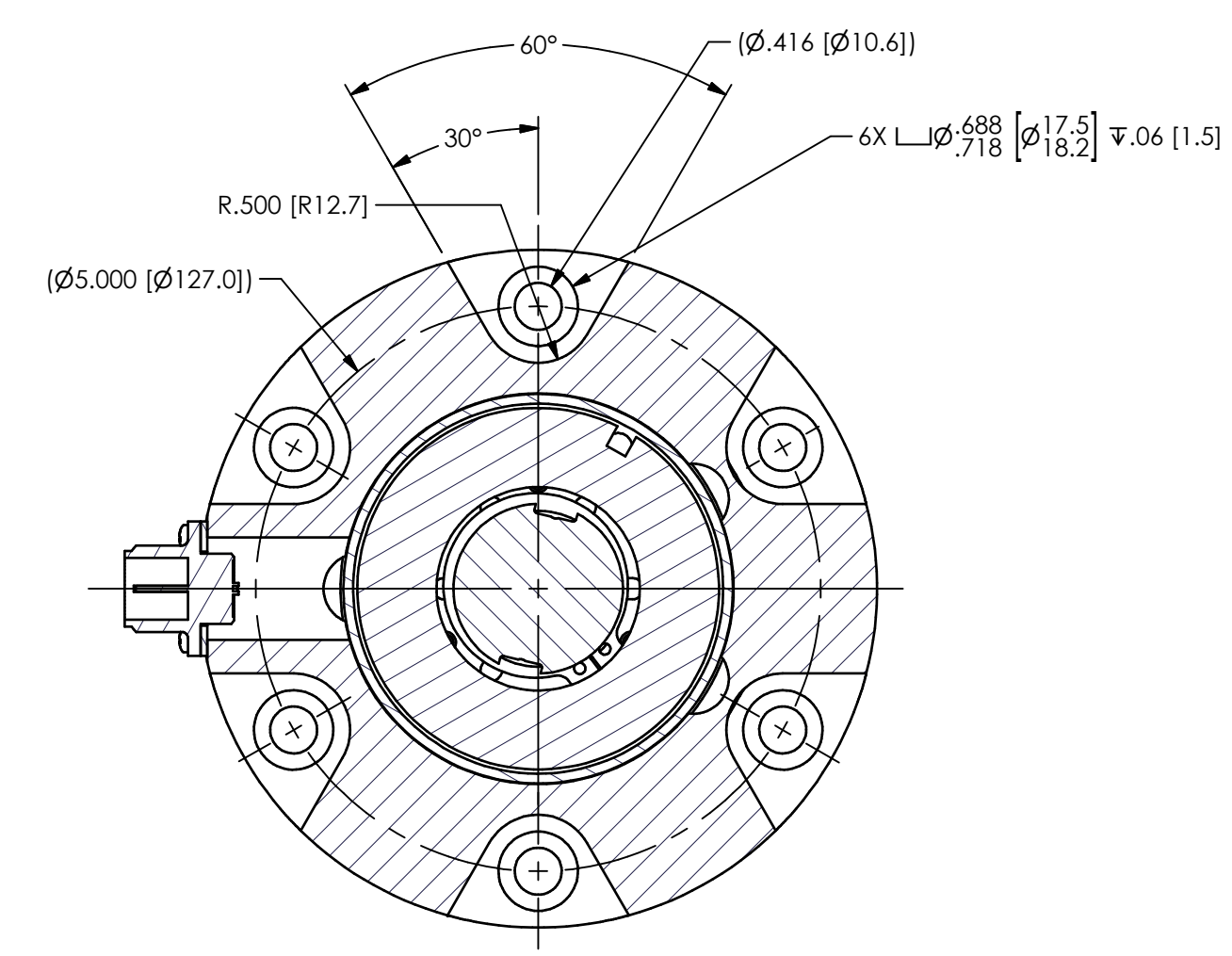
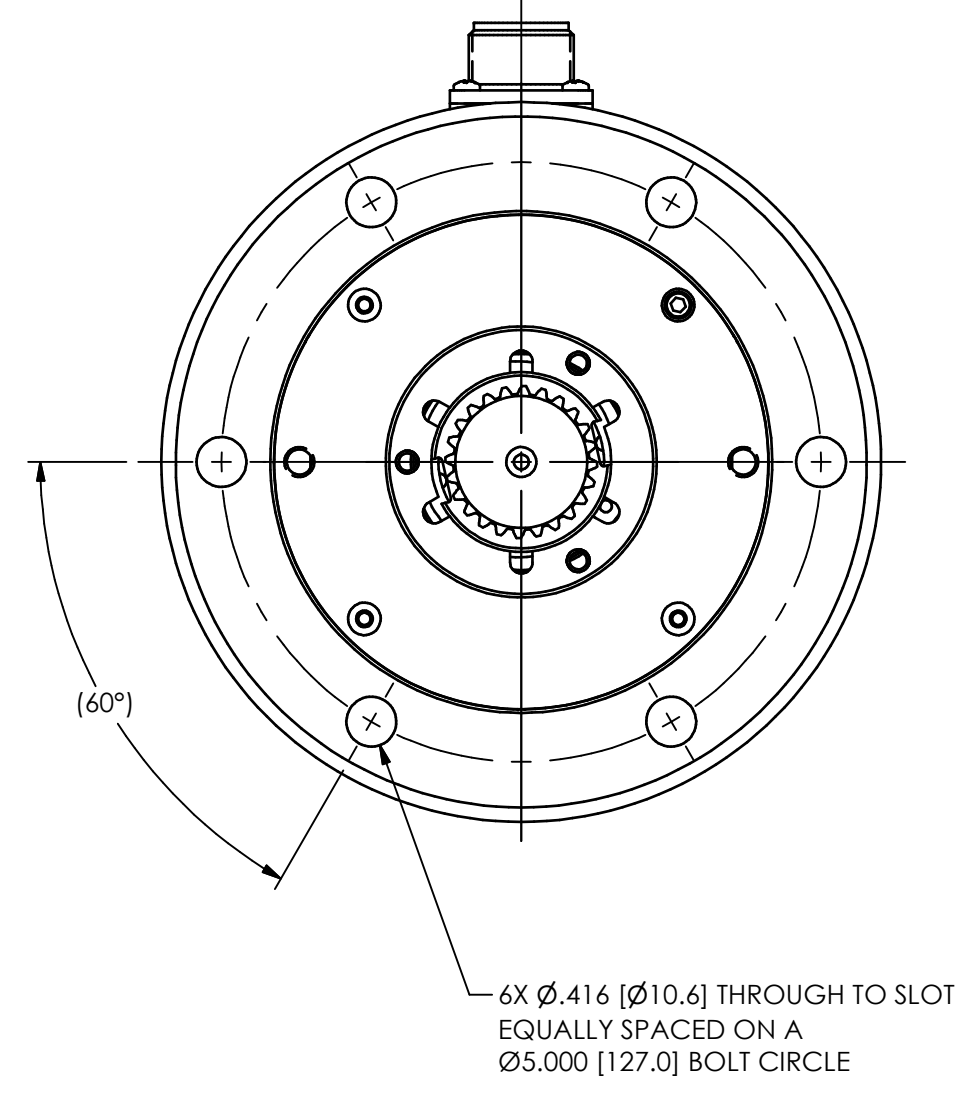
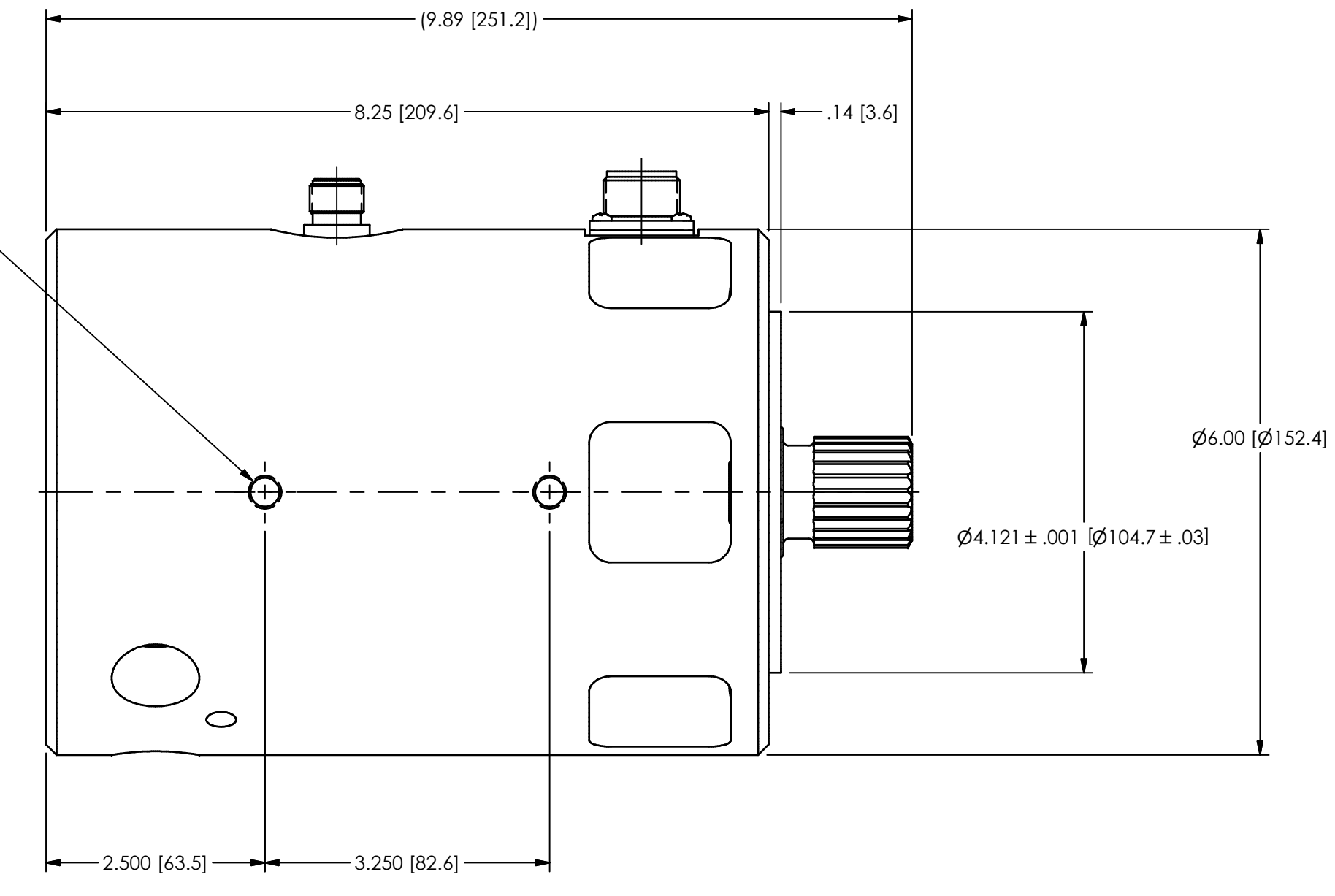
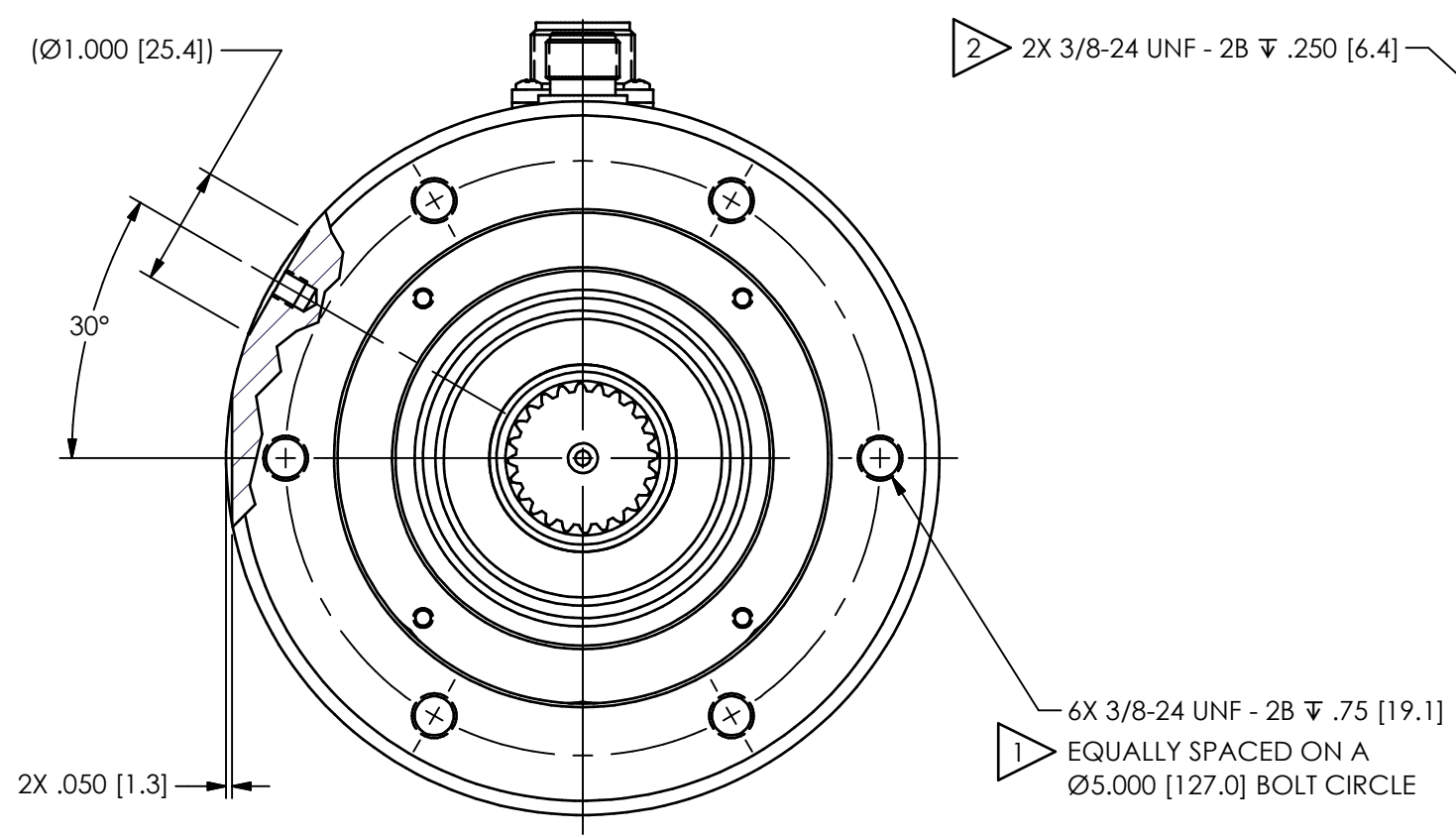
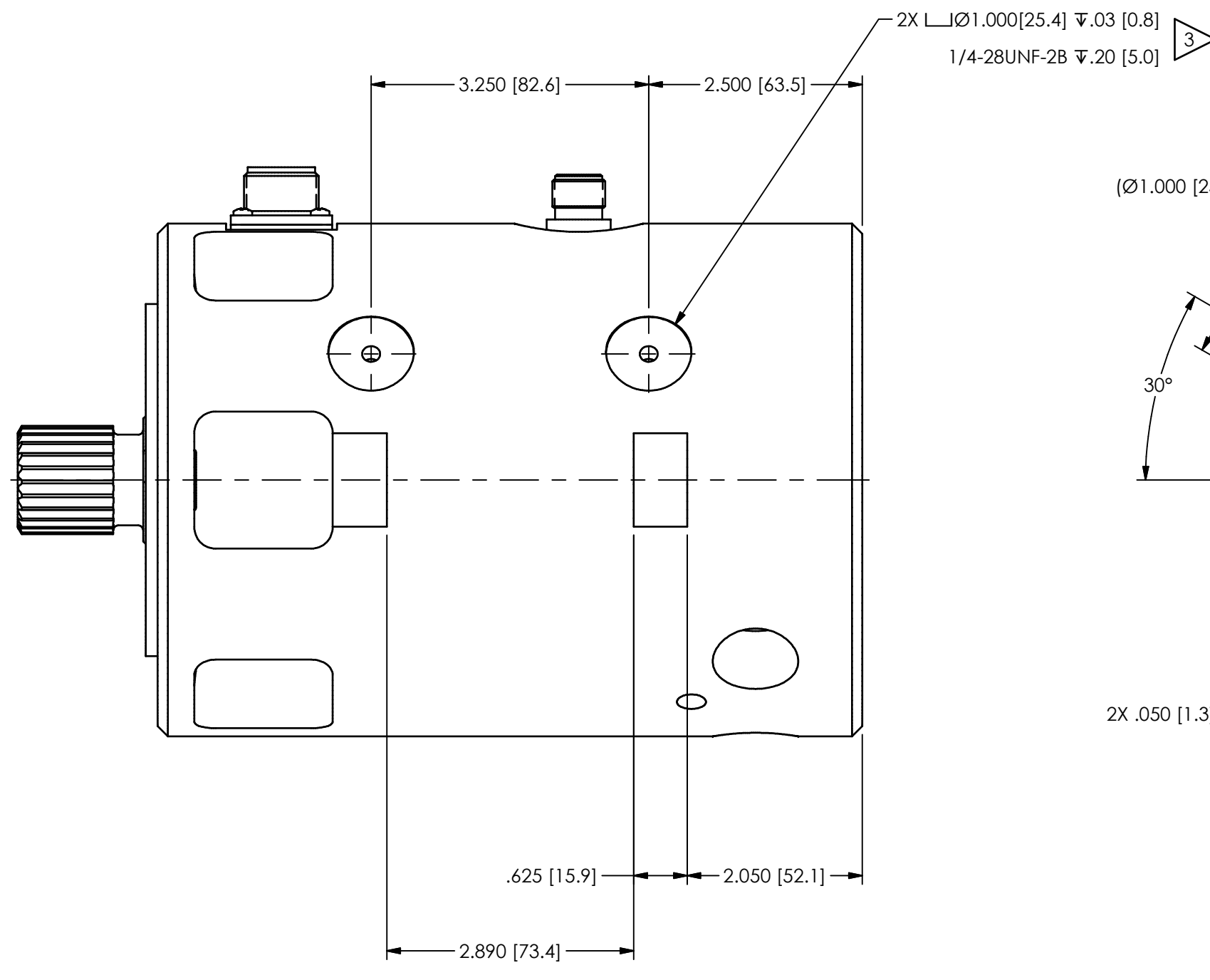
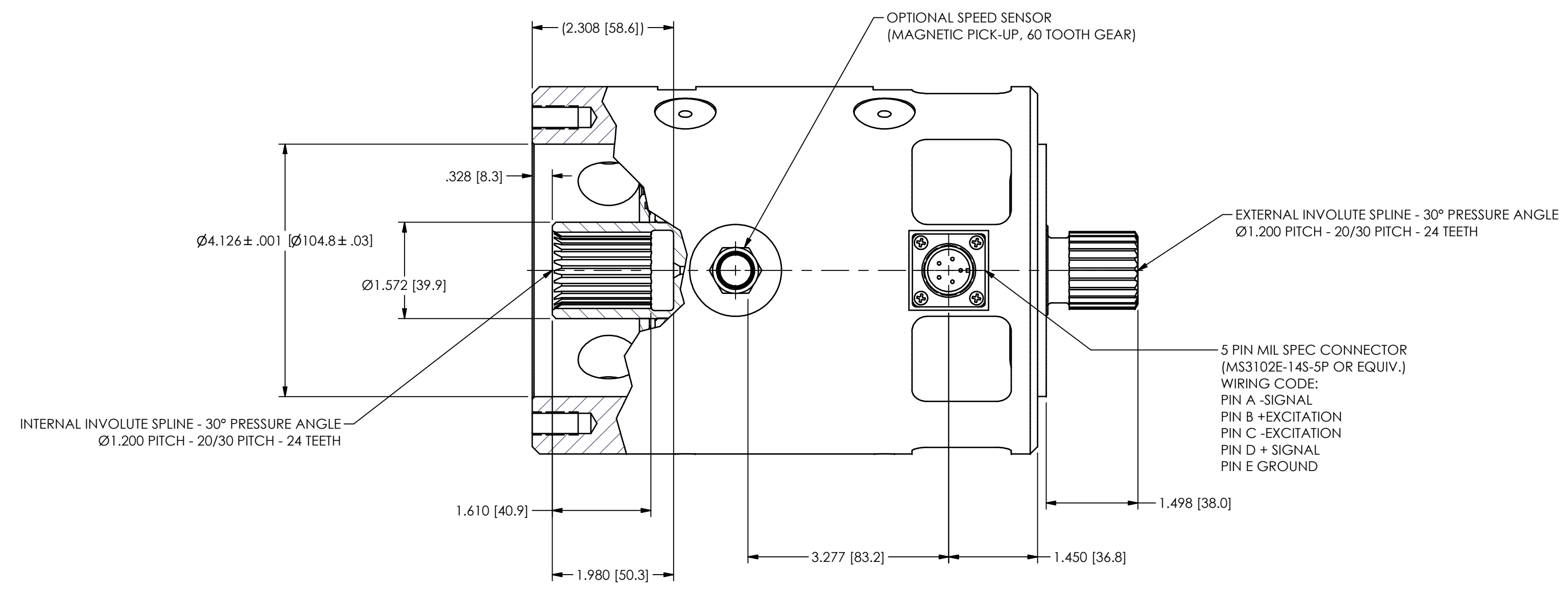
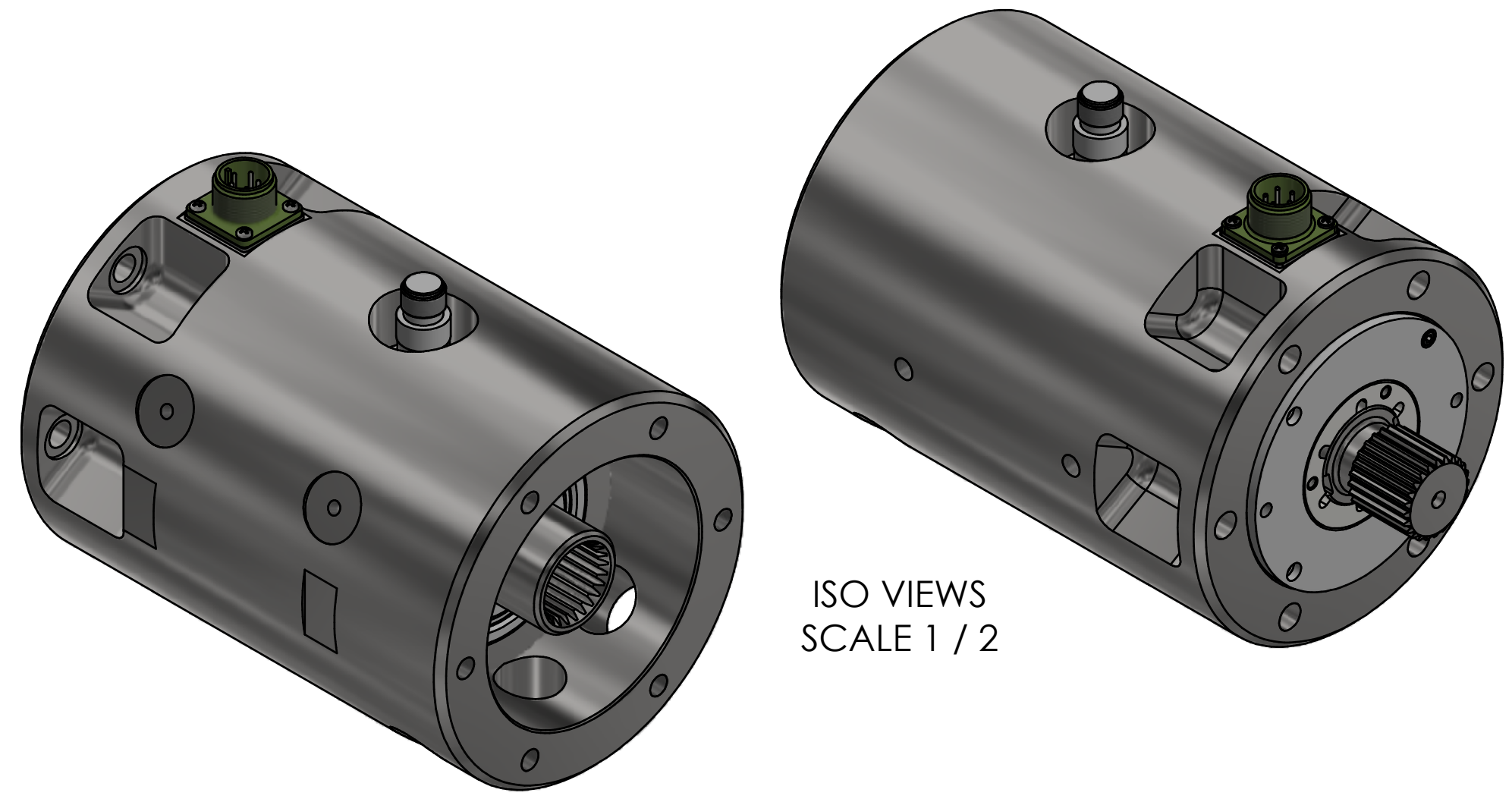

SECTION A-A

- NOTES:
- 1 3/8-24 TAPPED HOLES (6) PROVIDED FOR OPTIONAL STUDS
 - 2 3/8-24 TAPPED HOLES (2) PROVIDED FOR OPTIONAL THERMOCOUPLES FOR FOR BEARING TEMPERATURE MONITORING
 - 3 1/4-28 TAPPED HOLES (2) PROVIDED FOR OPTIONAL ACCELEROMETERS FOR VIBRATION MONITORING

UNLESS OTHERWISE SPECIFIED TOLERANCES ARE:		DRAWN			CHECKED			ENGINEER			PCB LOAD & TORQUE A PCB GROUP COMPANY
DIMENSIONS IN INCHES		PTE			JAM			PTE			
DECIMALS	XX ±.01 XXX ±.005	DATE			DATE			DATE			DWG. NO. 22675
ANGLES	± .5 DEGREES	TITLE			TITLE			TITLE			
FILES AND RADI	Ø15 MAX	OUTLINE DRAWING			OUTLINE DRAWING			OUTLINE DRAWING			SCALE: 5 / 8 SHEET 1 OF 1
FILES AND RADI	Ø15 MAX	MODEL 4115K SERIES			MODEL 4115K SERIES			MODEL 4115K SERIES			
FILES AND RADI	Ø15 MAX	ROTARY TRANSFORMER			ROTARY TRANSFORMER			ROTARY TRANSFORMER			