



**Model 2305-02A**

**PCB L&T Reaction Torque Transducer, 500k in-lb/41.7k ft-lb (56.5 kN-m) rated capacity, 50% static overload protection, 14-in (355.6 mm) Steel Flange**

**Installation and Operating Manual**

**For assistance with the operation of this product,  
contact the PCB Piezotronics, Inc.**

**Toll-free: 716-684-0001  
24-hour SensorLine: 716-684-0001  
Fax: 716-684-0987  
E-mail: [info@pcb.com](mailto:info@pcb.com)  
Web: [www.pcb.com](http://www.pcb.com)**



## TABLE OF CONTENTS

<b>Section</b>	<b>Page</b>
1.0 Introduction	2
2.0 Safety Information	3
3.0 Mechanical Installation	3
4.0 Electrical Installation	4
5.0 Polarity	4
6.0 Shunt Calibration	4
7.0 Operation	5
8.0 Troubleshooting	6
9.0 Maintenance	6

## LIST OF ILLUSTRATIONS

<b>Figure</b>	<b>Page</b>
1. Flange Mount Reaction Torque Sensor	2
2. Wheatstone Bridge Circuit	2
3. Western Regional Strain Gage Committee Wiring Code	2
4. Axis and Sense Nomenclature	3
5. Reaction Torque Sensor Configurations	3
6. Shunt Resistor Locations	4
7. Reaction Torque Sensor System Configurations	5

**1.0 INTRODUCTION**

Reaction torque sensors manufactured by the Force-Torque Division of PCB are strain gage based measuring instruments suitable for a wide range of torque measurement applications. They are rigid structures with no moving parts and are typically mounted in a fixed position. Their output signal varies proportionally to an applied torsional force. Capacities range from 5 to 500k in-lb (0.56 to 56.5k N-m).

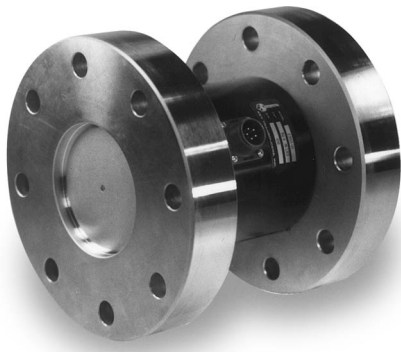

**Figure 1 – Flange Mount Reaction Torque Sensor**

Due to the fact that these sensors do not utilize bearings, slip rings, or any other rotating elements, their installation and use can be very cost effective. Reaction torque sensors are particularly useful in applications where the introduction of a rotating mass between the driver and driven is undesirable.

All models utilize strain gages configured into a Wheatstone Bridge Circuit to produce the primary sensing element. The four-arm Wheatstone Bridge configuration is shown below in **Figure 2**.

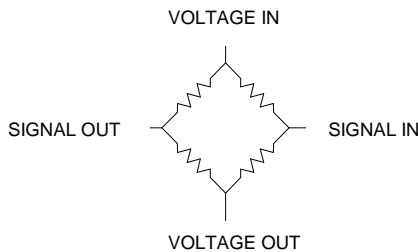

**Figure 2 - Wheatstone Bridge Circuit**

Most PCB reaction torque sensors follow a wiring code established by the Western Regional Strain

Gage Committee as revised in May 1960. The wiring code is as follows:

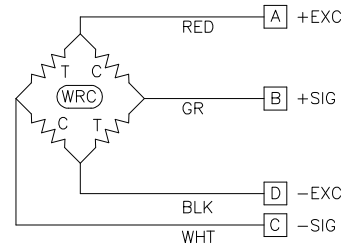

**Figure 3 - Western Regional Strain Gage Committee Wiring Code**

Refer to the wiring drawing included with this manual for specific wiring of the supplied torque sensor.

The gages are bonded to the sensor’s structure. Typically, a regulated DC or AC excitation is applied between A and D of the bridge. When torque is applied to the sensor, the Wheatstone Bridge becomes unbalanced, causing an output voltage between B and C which is proportional to the applied torque. The magnitude of the output voltage corresponds to the torsional deflection of the sensor structure and therefore the applied torque. This configuration allows for temperature and pressure compensation, as well as cancellation of signals caused by forces not directly applied to the axis of the applied load. Output is typically expressed in units of millivolt per volt of excitation.

Optional signal conditioners are available from PCB. A signal conditioner may have analog voltage output, current output, or digital output. Digital display signal conditioners are also available.

**Axis Definition**

PCB force products comply with the Axis and Sense Definitions of NAS-938 (National Aerospace Standard-Machine Axis and Motion) nomenclature and recommendations of the Western Regional Strain Gage committee. These axes are defined in terms of a "Right Handed" orthogonal coordinate system as show below. A (+) sign indicates force in a direction which produces a (+) signal voltage and generally defines a clockwise torque.

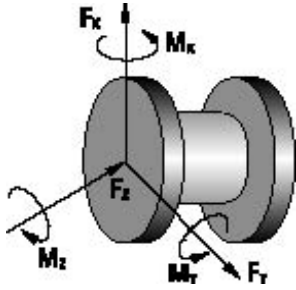

Figure 4 - Axis and Sense Nomenclature for PCB Reaction Torque Sensors

The principal axis of a transducer is normally the  $M_z$  axis. The  $M_z$  axis will also be the axis of radial symmetry or axis of rotation. In the event there is no clearly defined axis, the following preference system will be used z,x,y.

**2.0 SAFETY INFORMATION**

Failure of the sensor structure or fasteners used in its installation may cause personal injury and equipment damage. To prevent structure failure, review the extraneous load limits listed on the specification sheet supplied with this manual. Extraneous load limits are extraneous side force,

thrust and bending moment that may be applied without electrical or mechanical damage to the torque sensor. Do not exceed moment ( $W \times S$ ) or shear ( $W$ ) whichever attained first. Measurement inaccuracy and structure damage may result. Install the sensor in a manner that minimizes these loads. In addition, review data from manufacturers of fixtures and fasteners used in the sensors installation to determine if failure might occur due to these loads.

**3.0 MECHANICAL INSTALLATION**

Refer to the outline drawing supplied with this manual for specific outline dimensions and installation details for your particular model. The specification is also included to provide details of the sensor’s characteristic properties.

Shown below are some of the standard reaction torque sensor configurations offered by the Force/Torque Division.

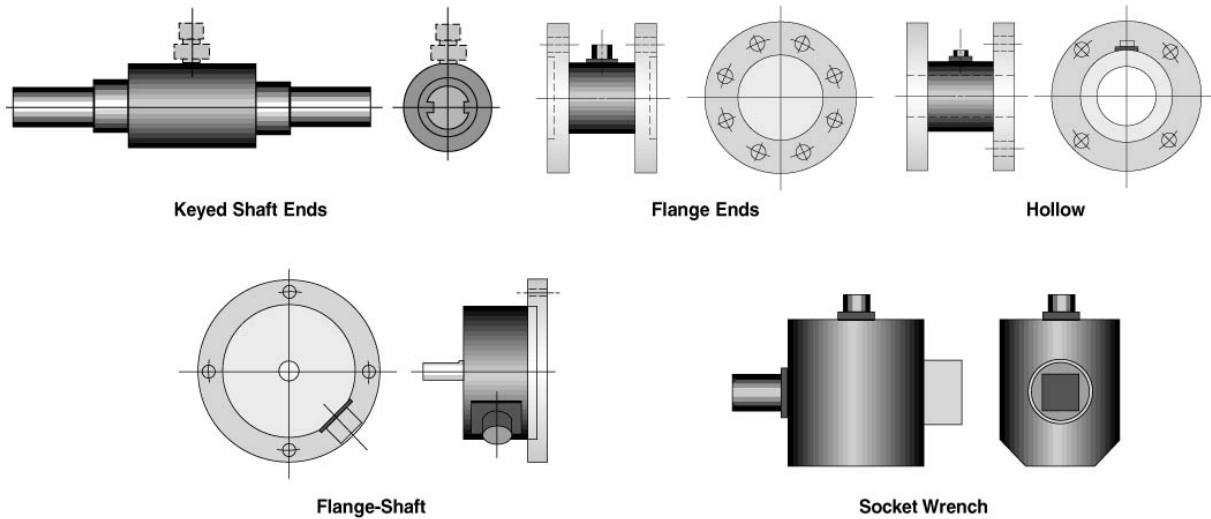

Figure 5 – Reaction Torque Sensor Configurations

## 4.0 ELECTRICAL INSTALLATION

For proper electrical connections, refer to the installation drawing for the torque sensor, and the wiring drawing for the signal conditioner used. Construct the interconnect cable from high-quality shielded instrumentation cable. Various cable assemblies are available through PCB.

Connect one end of the cable to the sensor connector and the other end to the signal conditioner. Make sure to tighten the cable connector to the sensor. For installation in dirty, humid, or rugged environments, it is suggested that the connection be shielded against dust or moisture with shrink tubing or other protective material. Strain relieving the cable/sensor connection can also prolong cable life. Mounting cables to a test structure with tape, clamps, or adhesives minimizes cable whip.

## 5.0 POLARITY

Clockwise torque upon standard PCB reaction torque sensors produces a positive-going voltage output. Counter-clockwise torque produces a negative-going voltage output.

## 6.0 SHUNT CALIBRATION

Shunt calibration is the known, electrical, unbalancing of a strain gage bridge by means of a fixed resistor that is placed, or “shunted”, across one leg of the bridge. The “Wheatstone Bridge” utilized by PCB reaction torque sensors are typically calibrated using the shunt calibration technique.

Shunt calibration is a method of periodically checking the gain or span of a signal conditioner, which is used in conjunction with a strain gage based transducer, without exposing the transducer to known, traceable, physical input values. If required, adjustments can then be made to the signal conditioner to insure accurate measurement results.

The strain gage bridge is “in balance” when the host mechanical structure is unloaded and unstressed.

As the host structure (diaphragm, bending beam, shear beam, column, etc.) is loaded or stressed, the Wheatstone Bridge becomes unbalanced, resulting in an output signal that is proportional to the applied load.

Shunt calibration simulates the mechanical input to a transducer by unbalancing the bridge with a fixed resistor placed across, or in parallel with, one leg of the bridge. For tension shunt calibration, or +CAL, the shunt resistor ( $R_{st}$ ) is shunted across the +Excitation (A) and +Signal (B) leg of the bridge. For compression shunt calibration, or -CAL, the shunt resistor ( $R_{sc}$ ) is shunted across the -Excitation (D) and +Signal (B) leg of the bridge. Refer to **Figure 6** for shunt resistor locations in the Wheatstone Bridge circuit.

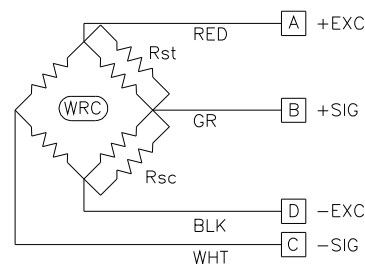

Figure 6 - Shunt Resistor Locations

### Shunt Calibration Procedure

1. Connect the transducer to an appropriate strain gage signal conditioner and allow adequate time for the system to stabilize.
2. Apply a full-scale, N.I.S.T. traceable, mechanical input (or torque) to the transducer.
3. Adjust the signal conditioner's gain or span controls, as required, to obtain a full-scale electrical output signal, and/or numeric display that represents the applied, mechanical input quantity.
4. Remove the mechanical input (or torque).
5. Place the shunt calibration resistor across an appropriate leg of the Wheatstone Bridge as discussed above.

6. Record the value of the signal conditioner's output signal and/or numeric display. This value is the shunt calibration value, or equivalent torque.
7. It is important to note that the shunt calibration value is specific for the particular shunt resistor

used. This value, and the particular resistor, are now matched to the transducer and form a basis of the transferable shunt calibration.

**Recalculating Shunt Calibration Value**

The shunt calibration resistor value and the resulting transducer output can be recalculated using the following formula:

$$\frac{\text{Supplied Transducer Output}}{\text{New Transducer Output}} = \frac{\text{New Resistor Value}}{\text{Supplied Resistor Value}}$$

Shunt calibration is accepted throughout the industry as a means of periodic calibration of a signal conditioner and transducer between calibrations of known, applied, traceable, mechanical, input values. Consequently, most all strain gage transducer manufacturers collect and supply shunt calibration data, along with a shunt calibration resistor, as a standard feature.

**7.0 OPERATION**

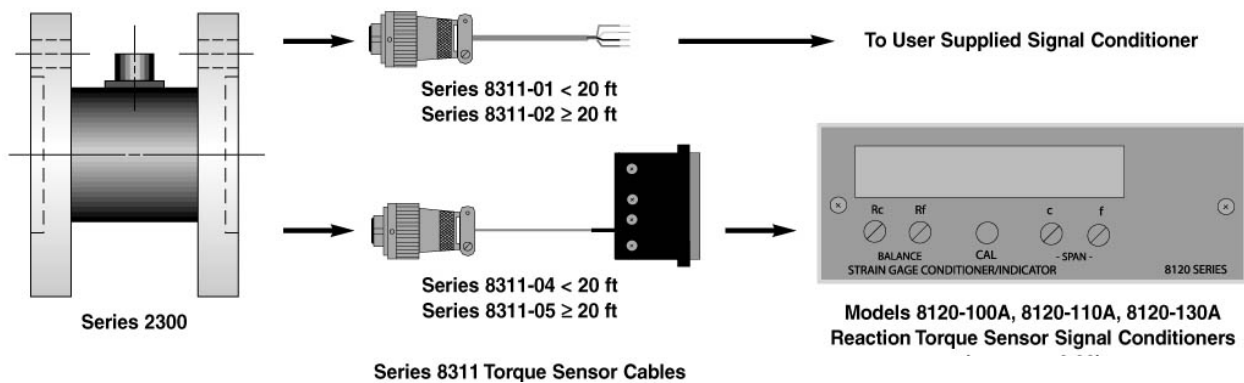

Figure 7 – Reaction Torque Sensor System Configurations

**Typical Reaction Torque Sensor System Configurations**

Operation requires the connection of the sensor to a signal conditioner, then to a readout device (if signal conditioner does not have a display). Strain gage signal conditioners and cable assemblies are available from PCB.

**Operation with a Signal Conditioner**

The signal conditioner span and zero must be set before the torque sensor system can be used. The span can be set using dead weights or the shunt calibration value. Refer to the shunt calibration information in this manual, and the signal conditioner instruction manual, for proper set-up information.

## 8.0 TROUBLESHOOTING

### No output

- ✓No power
- ✓Loose or dirty connections
- ✓Circuit opens or shorts
- ✓Faulty or improper wiring
- ✓No load applied

### Erratic or Improper Readings

- ✓Excitation voltage drift
- ✓Electrical noise
- ✓Loose fixturing
- ✓Circuit opens or shorts
- ✓Improper torque applied
- ✓Cable too long

### Blinking Display

- ✓Overload condition
- ✓Open circuit

### Zero Balance

- ✓Torque applied to sensor
- ✓Overloaded or side-loaded sensor
- ✓Open circuit
- ✓Improper electrical connections

### Zero Shift

- ✓Fixture preload
- ✓Faulty or improper wiring
- ✓Improper tare

### Zero Drift

- ✓Unconditioned power supply
- ✓Circuit opens or shorts
- ✓Loose wiring
- ✓RFI/EMI interface
- ✓Temperature change

### Damaged or Deformed Equipment

- ✓Improper use

Often overlooked by the customer, is the error due to the presence of non-measured forces and bending moments. Even Though the Single Axis of

Measurement sensors are designed and built to withstand these non-measured forces and bending moments (extraneous loads), the errors due to them are present. PCB engineers can design the set-up to eliminate or minimize these extraneous loads. However, if these extraneous loads are present, the errors due to them should be considered. Due to cost restraints, the Force/Torque Division, as with its competition, does not typically measure or compensate for errors due to extraneous loads. If the presences of these extraneous loads are known, the user should request the transducer manufacturer to run a special test, at extra cost, to define and quantify the extraneous load errors. These errors are defined as cross-talk errors.

### Error Analysis

The Force/Torque Division typically supplies accuracy information on its products in the form of individual errors (see specification sheet). They are: Non-Linearity, Hysteresis, Non-Repeatability, Effect of Temperature on Zero, and Effect of Temperature on Output.

The customer can combine these individual errors to establish the maximum possible error for the measurement or just examine the applicable individual error. If the temperature remains stable during the test, temperature related errors may be ignored. If the sensor is used for increasing load measurement only, ignore the Hysteresis error. If the load measurement is near the full capacity, the linearity error can be ignored. If the capability exists to correct the data through linearization-fit or a look-up-table, the error in the measurement can be minimized. A sophisticated user can get rid of all the errors except for the non-repeatability error in the measurement.

## 9.0 MAINTENANCE

Routine maintenance, such as cleaning of electrical connectors, housings, and mounting surfaces with solutions and techniques that will not harm the physical material of construction is acceptable.

Caution should be observed to insure that liquids are not permitted to migrate into devices that are not hermetically sealed. Such devices should only be wiped with a damp cloth and never submerged or have liquids poured on them.

Model Number <b>2305-02A</b>	<b>REACTION TORQUE SENSOR</b>	Revision: D ECN #: 47636
---------------------------------	-------------------------------	-----------------------------

	<b>ENGLISH</b>	<b>SI</b>	
<b>Performance</b>			
Measurement Range(Full Scale Capacity)	500,000 lbf-in	56,492 Nm	[1]
Sensitivity(± 15 %)(output at rated capacity)	2 mV/V	2 mV/V	[1][5]
Non-Linearity	≤ 0.1 % FS	≤ 0.1 % FS	[5]
Hysteresis	≤ 0.1 % FS	≤ 0.1 % FS	[5]
Non-Repeatability	≤ 0.02 % FS	≤ 0.02 % FS	[5]
Resonant Frequency	780 Hz	780 Hz	
Maximum Torque	750,000 lbf-in	84,738 Nm	
<b>Environmental</b>			
Overload Limit(Axial Thrust)	500,000 lbf	2224 kN	[3]
Overload Limit(Overhung Moment)	250,000 lbf-in	28,246 Nm	[3]
Overload Limit(Shear)	50,000 lbf	224.4 kN	[3]
Temperature Range(Operating)	-65 to 200 °F	-54 to 93 °C	
Temperature Range(Compensated)	+70 to 170 °F	+21 to 77 °C	
Temperature Effect on Output(Maximum)	± 0.002 %Reading/°F	± 0.0036 %Reading/°C	[4]
Temperature Effect on Zero Balance(Maximum)	± 0.002 %FS/°F	± 0.0036 %FS/°C	[4][5]
<b>Electrical</b>			
Bridge Resistance	350 Ohm	350 Ohm	[1]
Excitation Voltage(Recommended)	10 VDC	10 VDC	[2]
Insulation Resistance	5 GOhm	5 GOhm	
Zero Balance	≤ 1 %RO	≤ 1 %RO	
<b>Physical</b>			
Size (Diameter x Length)	14.00 in x 10.50 in	355.65 mm x 266.70 mm	[6]
Weight	225 lb	102.06 kg	
Mounting	Flange (1 in Bolts)	Flange (M24 Bolts)	
Torsional Stiffness	150,000 klbf-in/radian	16,947 kN-m/radian	
Sensing Element	Strain Gage	Strain Gage	
Housing Material(Sensor)	Plated Steel	Plated Steel	
Electrical Connector	PT02E-10-6P	PT02E-10-6P	

All specifications are at room temperature unless otherwise specified.  
 In the interest of constant product improvement, we reserve the right to change specifications without notice.

**OPTIONAL VERSIONS**

Optional versions have identical specifications and accessories as listed for the standard model except where noted below. More than one option may be used.

**NOTES:**  
 [1] Nominal.  
 [2] Calibrated at 10 VDC, usable 5 to 20 VDC or VAC RMS.  
 [3] Singularly applied, i.e. no other extraneous loads.  
 [4] Over compensated operating temperature range.  
 [5] FS - Full Scale.  
 [6] See Drawing 26443 for Complete Dimensions

**SUPPLIED ACCESSORIES:**  
 Model 181-012A PT06A-10-6S(SR) (1)

Entered: LK	Engineer: PE	Sales: KH	Approved: JSD	Spec Number:
Date: 2/22/2018	Date: 2/22/2018	Date: 2/22/2018	Date: 2/22/2018	<b>25800</b>



**PCB LOAD & TORQUE**  
A PCB PIEZOTRONICS DIV.

**PCB Load & Torque**  
 A Division of PCB Piezotronics  
 24350 Indoplex Circle  
 Farmington Hills, MI 48335  
 UNITED STATES  
 Phone: 866-684-7107  
 E-Mail: LTSales@pcb.com  
 Web site: www.pcb.com/LoadAndTorque

PCB Load & Torque Inc. claims proprietary rights in the information disclosed hereon. Neither it nor any reproduction thereof will be disclosed to others without the written consent of PCB Load and Torque Inc.

26443

REVISIONS		
REV	DESCRIPTION	ECO
B	UPDATED DIM'S, REMOVED PIN OUT VIEW - 02.23.18, PTE	47634

B

A

B

A

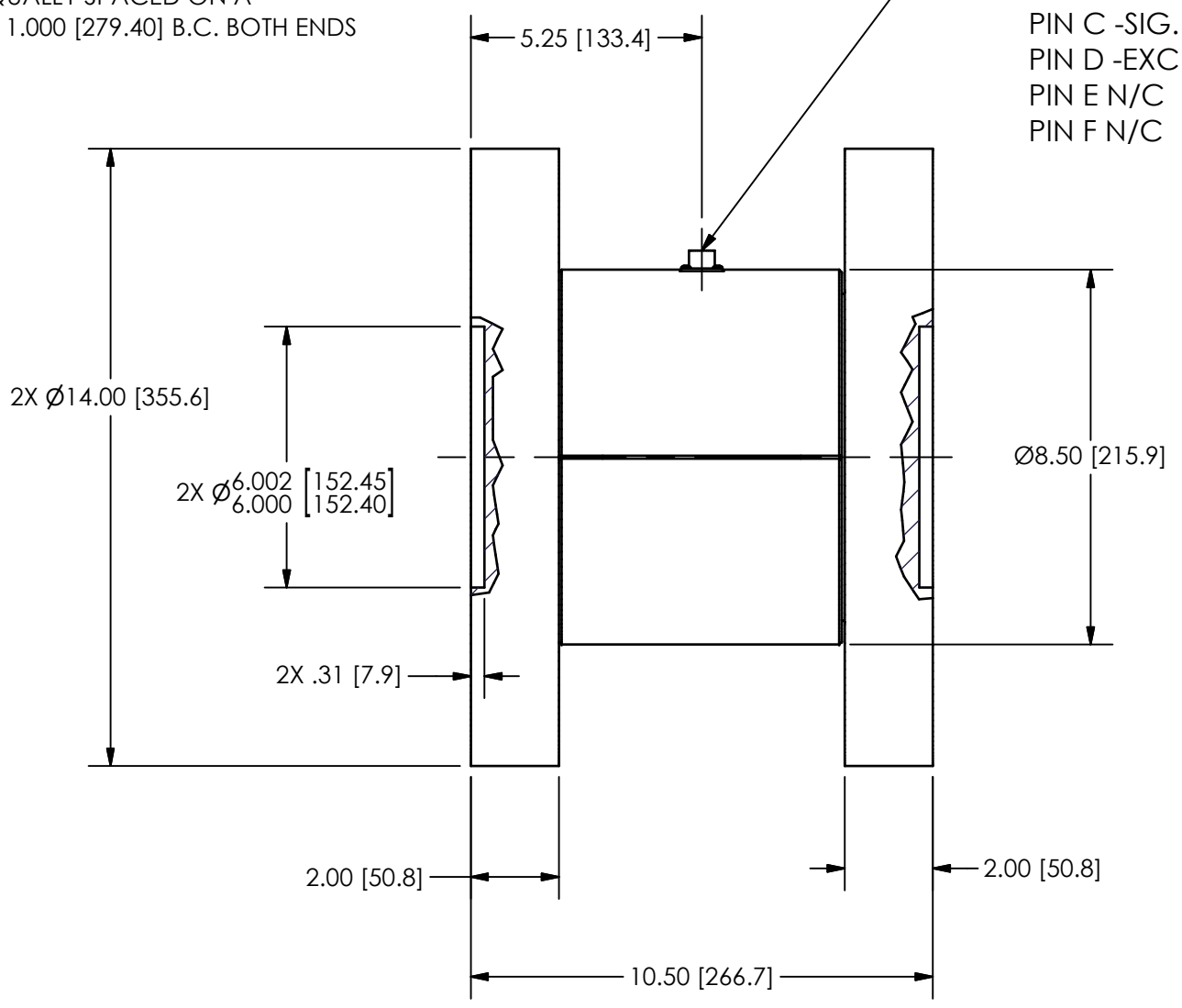
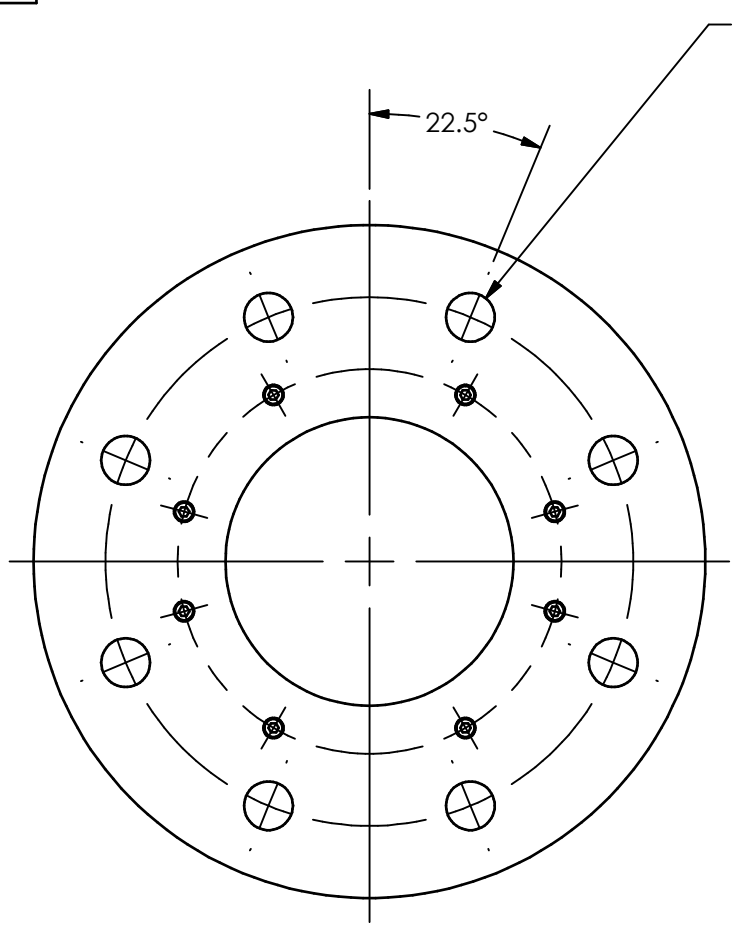

PUSH/TURN RECEPTACLE  
(BENDIX PT02E-10-6P OR EQUIV.)  
WIRING CODE (WR):  
PIN A +EXC.  
PIN B +SIG.  
PIN C -SIG.  
PIN D -EXC.  
PIN E N/C  
PIN F N/C

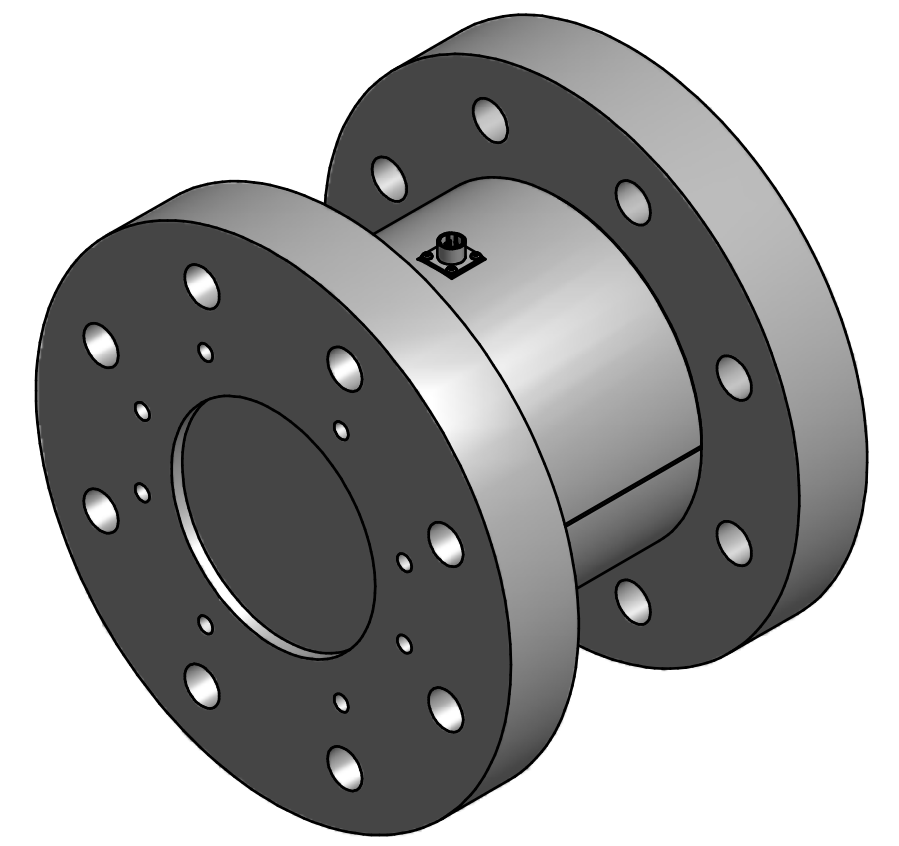

UNLESS OTHERWISE SPECIFIED TOLERANCES ARE:		DRAWN	CHECKED	ENGINEER		 <b>PCB LOAD &amp; TORQUE</b> A PCB GROUP COMPANY	
DIMENSIONS IN INCHES	DIMENSIONS IN MILLIMETERS [IN BRACKETS]			PTE	01.19.12		24350 Indoplex Circle, Farmington Hills, MI 48335 (716) 684-0001 E-MAIL: linfo@pcbloadtorque.com
DECIMALS XX ±.01 XXX ±.005	DECIMALS X ±.3 XX ±.13	TITLE				<b>OUTLINE DRAWING</b> MODEL 2305-XXA SERIES REACTION TORQUE SENSOR	DWG. NO.
ANGLES ± .5 DEGREES	ANGLES ± .5 DEGREES						26443
FILLETS AND RADII .015 MAX	FILLETS AND RADII 0.38 MAX					SCALE: 1/4	SHEET 1 OF 1

4

3

2

1