



**Model 027137-04022**

**PCB L&T Hand Torque Wrench, 200 in-lb (22.7 Nm), 12-inch Handle, 3/8-inch Square Drive, 4-Pin PT Receptacle**

**Installation and Operating Manual**

**For assistance with the operation of this product,  
contact the PCB Piezotronics, Inc.**

**Toll-free: 716-684-0001  
24-hour SensorLine: 716-684-0001  
Fax: 716-684-0987  
E-mail: [info@pcb.com](mailto:info@pcb.com)  
Web: [www.pcb.com](http://www.pcb.com)**





**CE**

# **Hand Torque-Angle Wrench Installation and Operating Manual**



**For assistance with the operation of this product, contact:  
RS Technologies  
Division of PCB Load & Torque, Inc.  
Toll-Free in USA: 888-684-2894  
24-hour SensorLine<sup>SM</sup>: 716-684-0001  
Fax: 248-888-8266  
E-mail: [rsinfo@pcbloadtorque.com](mailto:rsinfo@pcbloadtorque.com)**

**Introduction: Safety Considerations**

**CAUTION 1:** The Model 962 should not be opened by anyone other than factory personnel. There are no user serviceable parts inside of the Model 962 recorder.

**CAUTION 2:** Cables can kill your equipment. High voltage electrostatic discharge can damage electrical devices. Similar to a capacitor, a cable can hold a charge caused by triboelectric transfer, such as that which occurs in the following:

- Laying on and moving across a rug
- Any movement through air
- The action of rolling out a cable
- Contact with a non-grounded person.

The solution for product safety: 1) Connect the cables only with power switched OFF. 2) Temporarily “short” the end of the cable before attaching it to any signal input or output.

**WARNING SYMBOLS AND TERMS**

This symbol on the unit indicates that the user should refer to the operating instructions located in the manual.



This symbol on the unit indicates that high voltage may be present. Use standard safety precautions to avoid personal contact with this voltage.



This system indicates safety, earth ground.

The **WARNING** heading, if used in this manual, explains dangers that might result in personal injury or death. Always read the associated information very carefully before performing the indicated procedure.

The **CAUTION** heading, if used in this manual, explains hazards that could cause damage to the instrument.

1.0 INTRODUCTION

Hand Torque Wrenches manufactured by RS Technologies Division of PCB Load & Torque, Inc., are designed to accurately measure static torsional loads ranging from 2.0 lb-in up to 600 lb-ft (0.23 to 814 Nm). All models utilize strain gages configured into a Wheatstone Bridge Circuit to produce the primary sensing element. The four-arm Wheatstone Bridge configuration is shown below in **Figure 1**. Also pictured in **Figure 1** is the wiring code for the standard 10-pin PT receptacle.

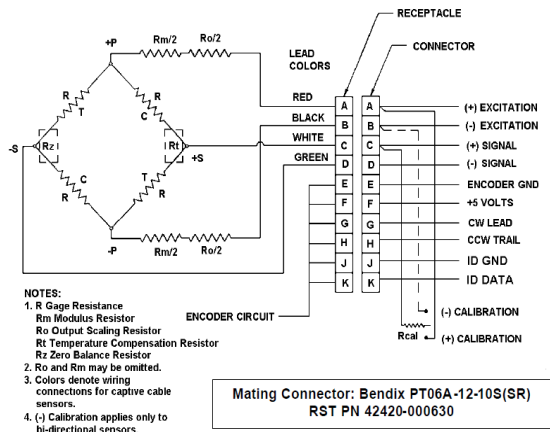

Figure 1—Hand Torque Wrench Wheatstone Bridge With Angle Wiring Code

The gages are bonded to the wrench’s flexure. Typically, a regulated DC or AC excitation is applied between A and B of the bridge. When torque is applied to the wrench, the Wheatstone Bridge becomes unbalanced, producing an output signal voltage between C and D, which is proportional to the applied load. The magnitude of the output signal corresponds to the deformation of the transducer and therefore the applied load. This configuration allows for temperature and pressure compensation, as well as cancellation of signals caused by forces not directly applied to the axis of the applied load. Output is typically expressed in units of millivolt per volt of excitation. Optional data collectors and signal conditioners are available from RS Technologies and PCB Load & Torque.

Angle is generated by a solid-state gyro mounted in the head of the torque wrench. With the gyro mounted in the head of the torque wrench, errors in angle measurement due to flex of the handle during tightening are eliminated. With the use of the solid-state gyro, no ‘angle tether’ is required against which angle values are referenced.

Specifications

<b>Full Scale Output</b> .....	2 mV/V (output and shunt calibration are matched to within ±0.25% to assure interchangeability; output is matched for specified English units.
<b>Shunt Calibration</b> .....	2.00 mV/V ±0.25% with 43.575k Ohm resistor
<b>Interchangeability</b> .....	Full scale output and shunt calibration are matched within ±0.3% to assure interchangeability
<b>Nonlinearity</b> .....	±0.25% Full Scale
<b>Hysteresis</b> .....	±0.25% Full Scale
<b>Zero Balance</b> .....	±2% Full Scale
<b>Overload Capacity</b> .....	150% of Full Scale
<b>Bridge Resistance</b> .....	350 Ohms, nominal
<b>Excitation</b> .....	10 vdc or vac (RMS)
<b>Compensated Temp Range</b> .....	70 to 150°F
<b>Useable Temp Range</b> .....	0 to 200 °F
<b>Receptacle</b> .....	Bendix PT02H-12-10P
<b>Mating Connector</b> .....	Bendix PT06A-12-10S(SR)
<b>Angle Output</b> .....	TTL (quadrature) 0-5vdc
<b>Angle Resolution</b> .....	0.125 degrees
<b>Angle Power</b> .....	5vdc
<b>Counts/Revolution</b> .....	2880 nominal
<b>Angle Accuracy</b> .....	±1% of reading ±1 degree @ angular velocity >10 deg/sec <180 deg/sec

Table 1. Capacities

Part No.	Drive Size	Handle	Capacity
027125-07012	¼-inch	8-in.	100 lb-in (11.4 Nm)
027137-07022	3/8-inch	12-in.	200 lb-in (22.7 Nm)
027137-07051	3/8-inch	12-in.	50 lb-ft (68 Nm)
027250-07101	½-inch	21-in.	100 lb-ft (136 Nm)
027250-07201	½-inch	21-in.	200 lb-ft (271 Nm)
027250-07301	½-inch	28-in.	300 lb-ft (407 Nm)
027375-07501	¾-inch	43-in.	500 lb-ft (678 Nm)

## 2.0 SAFETY INFORMATION

Applied loads must be limited to 100% of the rated capacity. Application of loads exceeding rated capacity can lead to damage of the hand torque wrench and potential injury to the operator. Therefore, always use care in applying torque to fasteners being audited or tightened failure. Operators should always observe standard shop safety requirements, such as wearing steel-toed shoes, safety glasses, etc.

## 3.0 MECHANICAL INSTALLATION

Mechanical installation consists of attaching the proper sized socket or drive fitting to the hand torque wrench. This socket or drive will be lined up with the fastener being tightened. Typical applications will be for auditing the residual torque in a previously assembled fastener, or for final tightening of a critical fastener.

## 4.0 ELECTRICAL INSTALLATION

The hand torque wrench is connected to a data collector or signal conditioner via the 10-pin PT receptacle located on the end of the handle. Cable assemblies for RS Technologies and other instruments are available through RS Technologies Division of PCB Load & Torque, Inc.

Connect one end of the cable to the wrench connector and the other end to the data collector signal conditioner. Make sure to completely tighten the cable connector to the wrench.

## 5.0 POLARITY

Clockwise torque on hand torque wrenches produces a positive-going signal output. Counterclockwise torque produces a negative-going signal output. Most data collectors provide a CW/CCW adjustment to ensure accurate readings.

## 6.0 SHUNT CALIBRATION

Shunt calibration is the known, electrical unbalancing of a strain gage bridge by means of a fixed resistor that is placed, or “shunted”, across one leg of the bridge. The Wheatstone Bridge utilized by RS Technologies hand torque wrenches is typically calibrated using the shunt calibration technique.

Shunt calibration is a practical method for providing field calibration of data collectors and strain gage transducers such as hand torque wrenches. This provides assurance of obtaining accurate readings without having to apply known, traceable, physical input loads to the wrench, which may be impractical in an assembly line or out in the field.

Shunt calibration simulates the mechanical input to a transducer by unbalancing the bridge with a fixed resistor placed across, or in parallel with, one leg of the bridge. For clockwise shunt calibration, or +CAL, the shunt resistor ( $R_{CAL}$ ) is shunted across the +Excitation (A) and +Signal (C) leg of the bridge. For counterclockwise shunt calibration, or -CAL, the shunt resistor ( $R_{CAL}$ ) is shunted across the -Excitation (BD) and +Signal (C) leg of the bridge. See **Figure 1** for shunt resistor locations in the Wheatstone Bridge circuit.

Shunt calibration is accepted throughout the industry as a means of periodic calibration of a data collector and a hand torque wrench between calibrations of known, applied, traceable, mechanical input values. Consequently, most all strain gage transducer manufacturers collect and supply shunt calibration data, along with a shunt calibration resistor, as a standard feature.

The hand torque wrench provided by RS Technologies Division of PCB Load & Torque Inc. comes with a calibration certificate. On the first page of this certificate you will find a calibration value in engineering units that is associated with a particular resistor. This resistor can be installed on the data collector and used when matching up the instrument to the wrench. Follow the instructions provided with the data collector for complete details on shunt calibration procedures.

## 6.1 ANGLE CALIBRATION

If the torque-angle wrench will be used with an RS Technologies Model 920, 960, or 962 meter with auto ID enabled, the torque wrench parameters will be auto detected. If not using the torque-angle wrench with auto ID enabled, or if using a non-RS Technologies meter, manually enter the ‘Counts/Revolution’ value stated on the calibration certificate into the transducer’s definition before calibrating to meter to the wrench.

## 6.2 Basic Shunt Calibration Procedure

The following procedure outlines the basic routine of shunt calibration. The actual calibration procedure performed by your data collector may be automated and will differ. Consult the data collector instruction manual for further details.

1. Connect the hand torque wrench to the data collector and allow adequate time for the system to stabilize. 2 to 5 minutes is recommended.
2. With no load on the wrench, adjust the data collector zero controls for each bridge to read zero (0).
3. Shunt the calibration resistor between the desired excitation and signal leads of the Wheatstone Bridge, as described in Section 6.0.
4. Adjust the data collector's gain or span controls as required to obtain an electrical output signal and/or numeric display that represents the simulated calibration load as indicated on the calibration certificate.
5. Remove the shunt resistor and adjust the zero if necessary.
6. If a significant zero adjustment is required, repeat Steps 3-5.

## 7.0 OPERATION

### 7.1 Typical Hand Torque Wrench System Configurations

Operation requires the connection of the wrench to a readout device, data collector, or signal conditioner. Readout instruments, data collectors, and suitable cable assemblies are available from RS Technologies Division of PCB Load & Torque, Inc.

### 7.2 Operation with a Data Collector or Readout Device

The span and zero of the instrument must be set before the hand torque wrench system can be used. The span can be set using the shunt calibration value and resistor supplied by the manufacturer, or by a deadweight torque calibrator. Refer to the shunt calibration information in the instruction manual of the instrument for proper setup information.

### 7.3 Hand Torque Wrench Operation Guidelines

With the instrument power OFF, connect the torque/angle wrench to the instrument.

Set the torque/angle wrench on a table top such that the gyro status light is visible.

Switch the instrument power to ON. Do not move the torque/angle wrench until the gyro status light turns GREEN.

Calibrate the instrument to the torque-angle wrench. Use the angle counts per revolution as stated on the torque-angle wrench calibration certificate when defining the torque wrench calibration values.

During use, a GREEN gyro status light indicates gyro operation is normal.

If the status light flashes RED, angular velocity has exceeded the 180deg/sec limit and the angle reading may be in question. The status light will return to GREEN after several seconds and testing can continue.

Refer to Figures 3-6 for proper use of a hand torque wrench.

**NOTE:** To ensure best results, the square drive of the socket must be fully engaged with the drive of the hand torque wrench. Similarly, the hex drive of the socket must be fully engaged with the head of the fastener.

### 7.4 Rundown Status LED

When used with the Model 920 meter, the tri-color rundown status LED is used to indicate the pass/fail status of the last recording. Refer to Figure 2. Based upon the test setup parameters that have been programmed into the Model 920 meter, the LED indications are as follows:

RED:	Torque and, or, angle value above the programmed 'High Limit'.
GREEN:	Torque and angle values fall within the programmed 'High and Low Limit'.
YELLOW:	Torque and, or, angle value is below the programmed 'Low Limit'

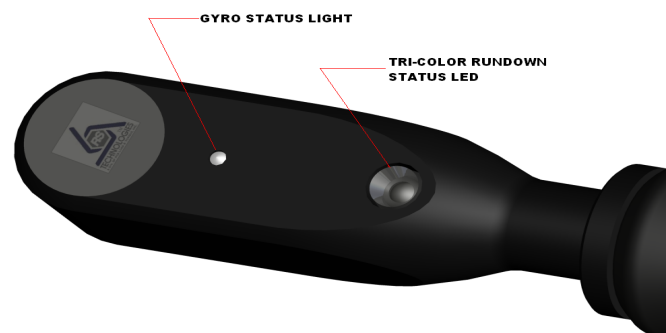

Figure 2—Hand Torque Angle Status Lights

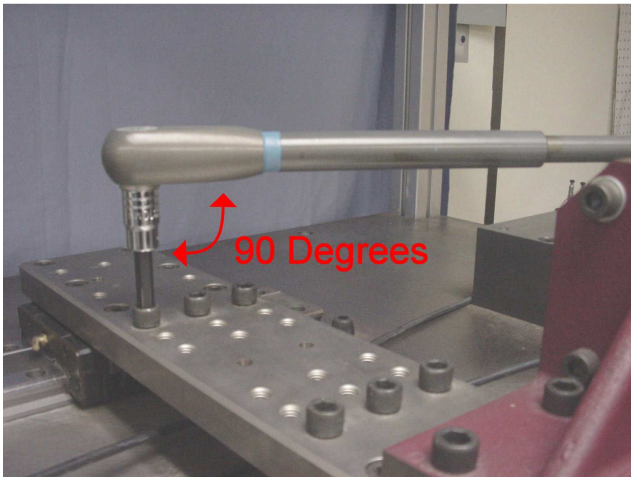

Figure 3—Hold the handle of wrench perpendicular to the centerline or shank of the fastener.

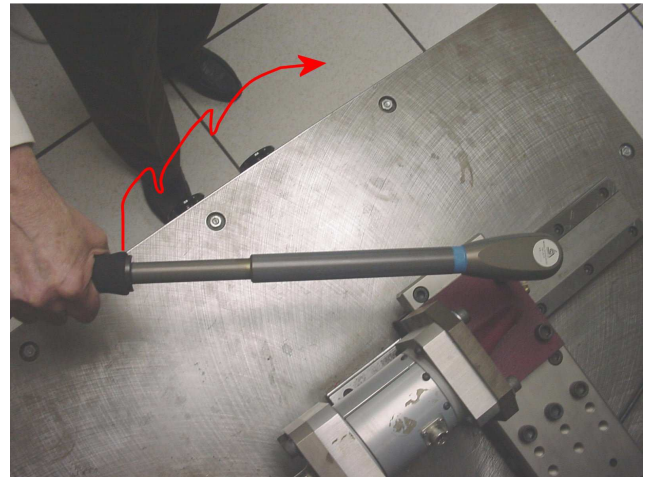

Figure 6—Do not jerk the handle abruptly or you may get inaccurate and inconsistent readings.

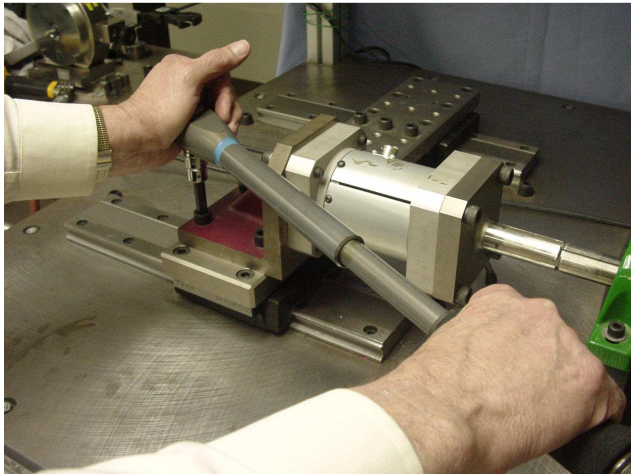

Figure 4—Support the head of wrench using one hand and prepare to pull with the other.

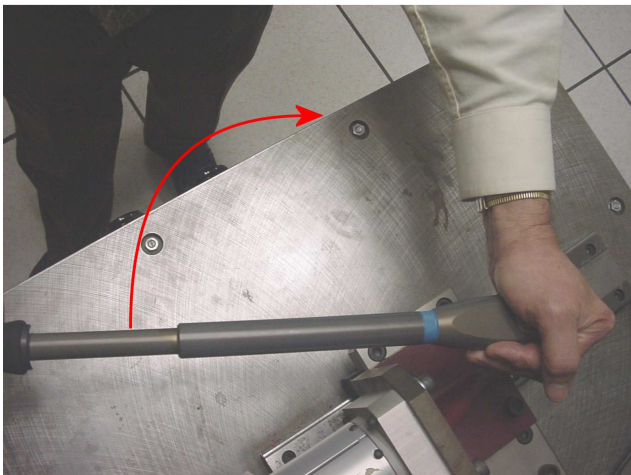

Figure 5—For best results, pull on the handle of the wrench with a smooth steady pull. Stop pulling the wrench handle either when the desired torque specification is reached or when the fastener breaks loose and the head of the fastener begins to rotate.

## 8.0 TROUBLESHOOTING

When having difficulty operating the hand torque wrench, refer to the following checklist.

### No output

- ✓No power
- ✓Loose or dirty connections
- ✓Open circuit or short
- ✓Faulty or improper wiring
- ✓No torque applied

### Erratic or Improper Readings

- ✓Excitation voltage drift
- ✓Electrical noise
- ✓Loose fixturing
- ✓Open circuit or short
- ✓Improper load applied
- ✓Cable too long

### Blinking Display

- ✓Overload condition
- ✓Open circuit

### Zero Balance

- ✓Load applied to wrench
- ✓Overloaded or side-loaded wrench
- ✓Open circuit
- ✓Improper electrical connections

### Zero Shift

- ✓Fixture preload
- ✓Faulty or improper wiring
- ✓Improper zero taken

**Zero Drift**

- ✓Unconditioned power supply
- ✓Open circuit or short
- ✓Loose wiring
- ✓RFI/EMI interface
- ✓Temperature change
- ✓Wrench moved on power ON before green gyro status LED obtained

**Flashing red gyro status LED**

- ✓Angular velocity has exceeded limit

**Damaged or Deformed Equipment**

- ✓Improper use

**Error Analysis**

PCB Load & Torque, Inc. typically supplies accuracy information on its products in the form of individual errors (see specification sheet). For hand torque wrenches they are: Non-Linearity, Hysteresis, and Non-Repeatability.

The customer can combine these individual errors to establish the maximum possible error for the measurement or just examine the applicable individual error. If the wrench is used for increasing torque measurement only, ignore the Hysteresis error. If the torque measurement is near the full rated capacity, the linearity error can be ignored. If the capability exists to correct the data through linearization-fit or a look-up-table, the error in the measurement can be minimized. A sophisticated user can get rid of all the errors except for the non-repeatability error in the measurement.

If problems persist, contact PCB Load & Torque for technical assistance.

**9.0 MAINTENANCE**

The hand torque wrenches provided by RS Technologies Division of PCB Load & Torque Inc. are made of durable materials, and are intended for industrial use. However, routine maintenance, such as cleaning of electrical connectors, housings, handle, and square drives with solutions and techniques that will not harm the physical material of construction is acceptable. The hand torque wrenches should only be wiped with a damp cloth and never submerged or have liquids poured on them.

###

*MANUAL NUMBER: 51051  
MANUAL REVISION: A  
ECN NUMBER: 37134*

Model Number  
027137-04022

# HAND TORQUE WRENCH

Revision: D  
ECN #: 53170

Performance	ENGLISH	SI	
Measurement Range(Full Scale Capacity)	200 in-lb	22.7 Nm	
Sensitivity(output at rated capacity) (0.25%FS)	2 mV/V	2 mV/V	[1]
Non-Linearity	≤ 0.25 % FS	≤ 0.25 % FS	[2]
Hysteresis	≤ 0.25 % FS	≤ 0.25 % FS	[2]
Interchangeability	≤ 0.30 % FS	≤ 0.30 % FS	[3]
Overload Capacity	150%F.S.	150%F.S.	
Drive Size	3/8 inch Square	3/8 inch Square	[4]
<b>Environmental</b>			
Temperature Range(Operating)	0 to +200 °F	-18 to +93 °C	
Temperature Range(Compensated)	+70 to +150 °F	+21 to +66 °C	
Temperature Effect on Output(Maximum)	± 0.01 %RO/°F	± 0.018 %RO/°C	
Temperature Effect on Zero Balance(Maximum)	± 0.01 %FS/°F	± 0.018 %FS/°C	
<b>Electrical</b>			
Isolation Resistance	≥ 1G Ohm	≥ 1G Ohm	
Bridge Resistance	350 Ohm	350 Ohm	
Excitation Voltage(Recommended)	10 VDC or VAC rms	10 VDC or VAC rms	
Zero Balance	≤ 2 % FS	≤ 2 % FS	
Shunt Calibration	2 mV/V	2 mV/V	[5]
Output Polarity	cw+	cw+	
<b>Physical</b>			
Size - Length	12.11 in	307.6 mm	[4]
Weight	12.8 oz	363 gm	
Mating Connector	PT06A-8-4S	PT06A-8-4S	
Connector	DT02H-8-4P	DT02H-8-4P	
Color Code	Yellow	Yellow	
Socket Retaining Type	Ball/Spring	Ball/Spring	

## OPTIONAL VERSIONS

Optional versions have identical specifications and accessories as listed for the standard model except where noted below. More than one option may be used.

## NOTES:

- [1]Nominal.
- [2]FS - Full Scale.
- [3]Matched for mV/V and shunt calibration.
- [4]See Drawing 52102 for Complete Dimensions
- [5]2 mV/V with 43.575 kOhm precision resistor.
- [6]See PCB Declaration of Conformance PS117 for details.

## SUPPLIED ACCESSORIES:

Model 7122R-04352A PRECISION CAL RESISTOR 43.575 kOhm

## OPTIONAL ACCESSORIES:

- Model 080922-01000 MODEL 922 DIGITAL PEAK METER
- Model 080962-01000 MODEL 962 DATA RECORDER
- Model 097000-34149 INTERCONNECT CABLE
- Model 4242R-000600 MATING CONNECTOR PT06A-8-4S



All specifications are at room temperature unless otherwise specified.  
In the interest of constant product improvement, we reserve the right to change specifications without notice.

Entered: ND	Engineer: NJN	Sales: DM	Approved: JM	Spec Number:
Date: 10/05/2022	Date: 10/05/2022	Date: 10/05/2022	Date: 10/05/2022	52091



PCB Load & Torque A Division of PCB  
Piezotronics  
24350 Indoplex Circle Farmington  
Hills, MI 48335  
UNITED STATES  
Phone: 866-684-7107  
E-Mail: LTSales@pcb.com  
Web site: www.pcb.com/LoadAndTorque

PCB Load & Torque (A Division of PCB Piezotronics, Inc.)  
 claims proprietary rights in the information disclosed herein.  
 Neither it nor any reproduction thereof will be disclosed to  
 others without the written consent of PCB Load and Torque.

52102

REVISIONS		
REV	DESCRIPTION	ECO
B	CHANGED DIMENSIONING/TOLERANCE - 01.12.22, PTE	52470

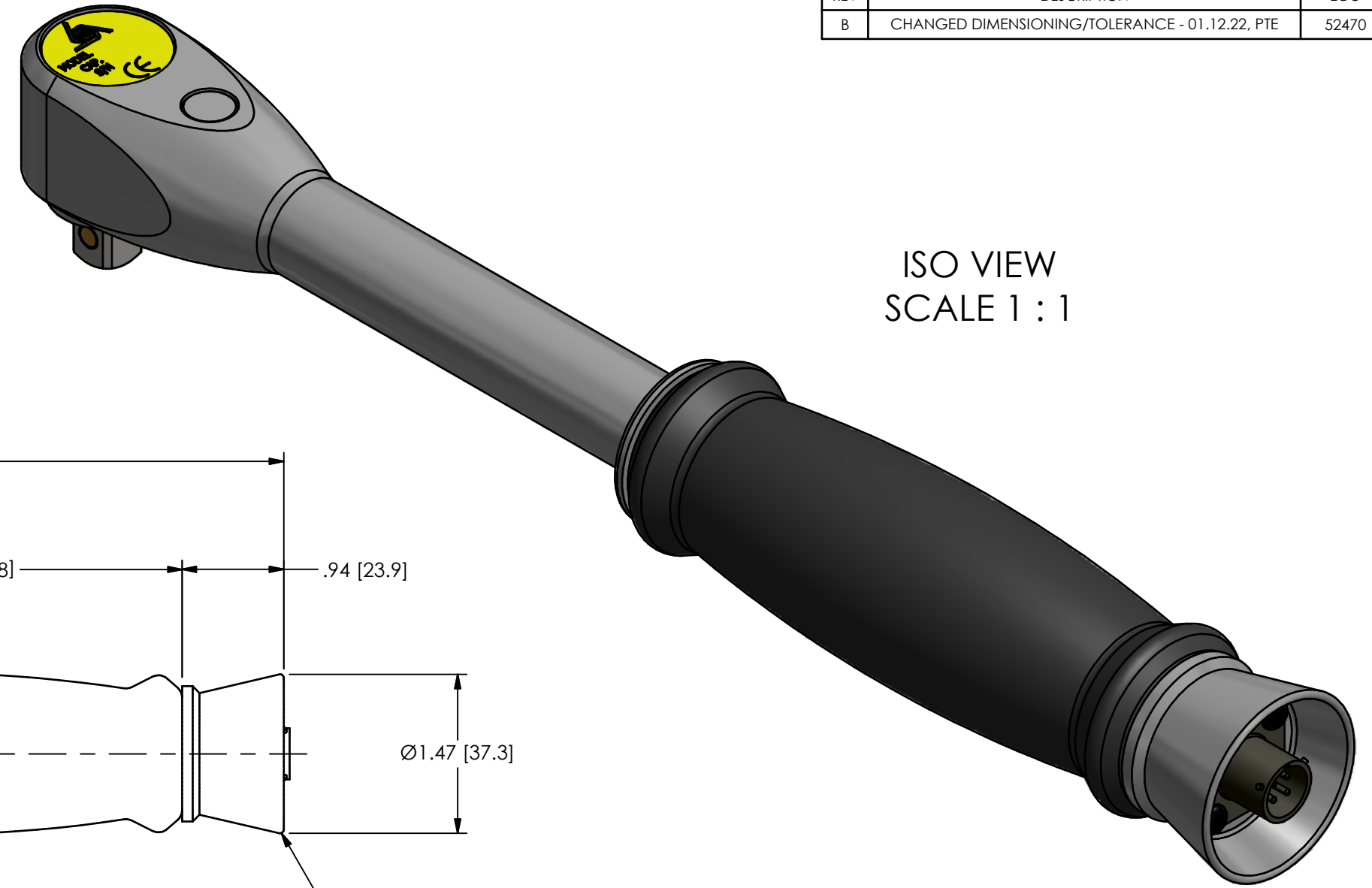

ISO VIEW  
 SCALE 1 : 1

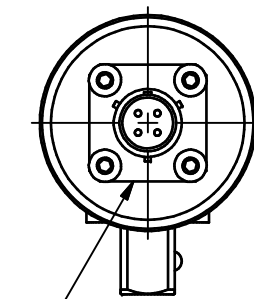
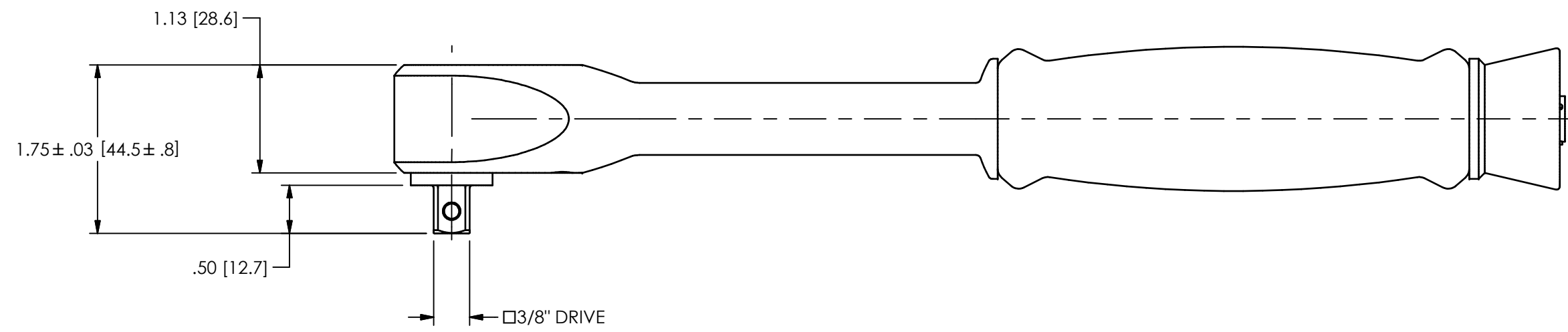
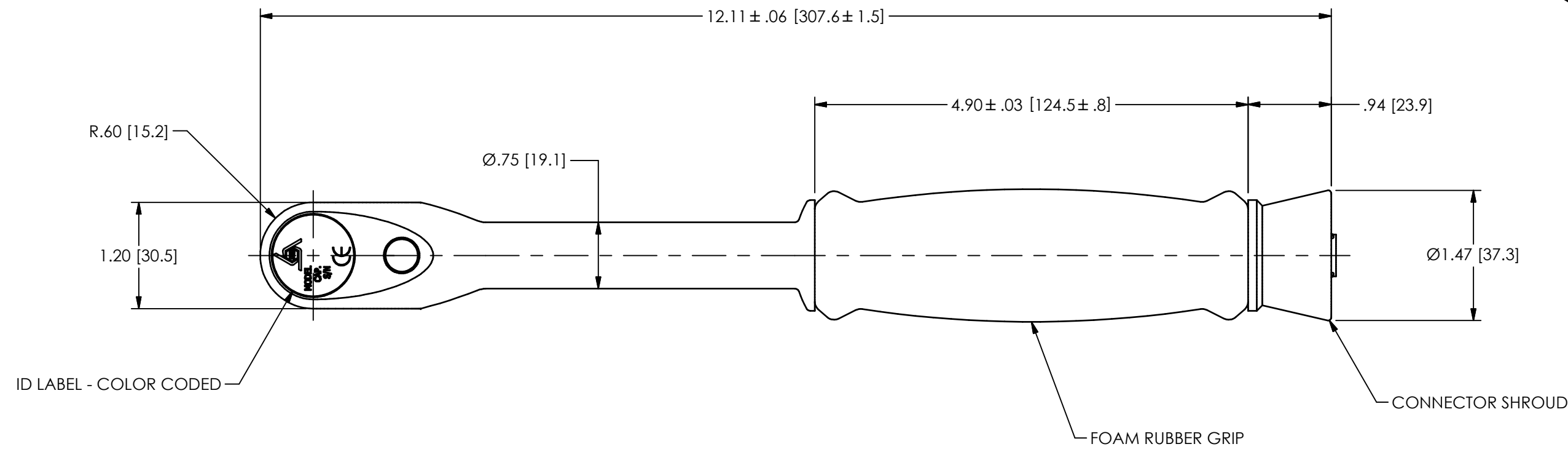

PUSH/TURN RECEPTACLE  
 (PTO2A-8-4P OR EQUIV.)  
 WIRING CODE:  
 PIN A +EXC.  
 PIN B -EXC.  
 PIN C +SIG.  
 PIN D -SIG.

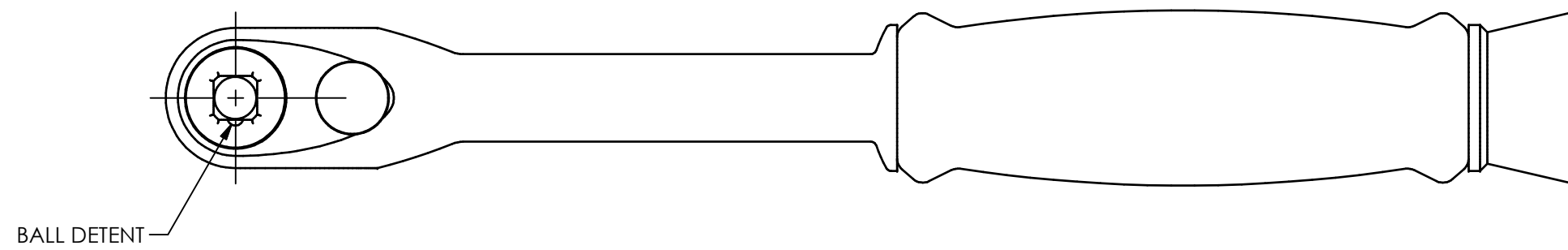

UNLESS OTHERWISE SPECIFIED TOLERANCES ARE:		DRAWN	CHECKED	ENGINEER		 24350 Indoplex Circle, Farmington Hills, MI 48335 (248) 888-8260 E-MAIL: linfo@pcb.com	
DIMENSIONS IN INCHES	DIMENSIONS IN MILLIMETERS [IN BRACKETS]	PTE	08.01.16	JSD	08.30.16		JAM
DECIMALS XX ±.01 XXX ±.005	DECIMALS X ± 0.3 XX ± 0.13	TITLE					
ANGLES ± .5 DEGREES	ANGLES ± .5 DEGREES	OUTLINE DRAWING 3/8" SQ. DRIVE (027137-04XXX) HAND TORQUE WRENCH					
FILLETS AND RADII .015 MAX	FILLETS AND RADII 0.38 MAX	DWG. NO. <b>52102</b> SCALE: 3/4 SHEET 1 OF 1					