

PCB Load & Torque (A Division of PCB Piezotronics, Inc.)
 claims proprietary rights in the information disclosed herein.
 Neither it nor any reproduction thereof will be disclosed to
 others without the written consent of PCB Load and Torque.

50913

REVISIONS		
REV	DESCRIPTION	ECO
B	CHANGED DIMENSIONING/TOLERANCE - 01.12.22, PTE	52470

ISO VIEW
 SCALE 1 / 2

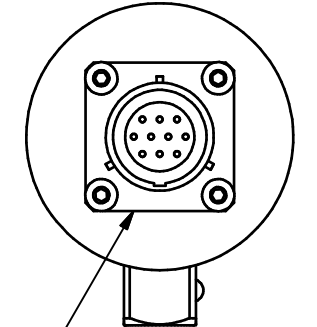
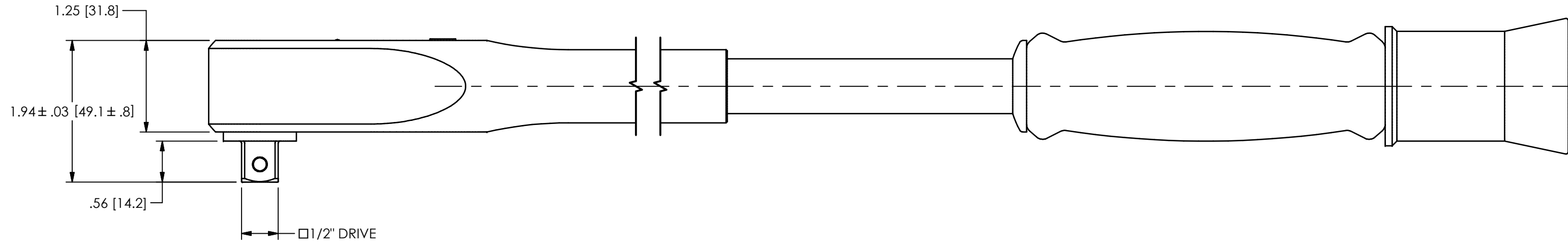
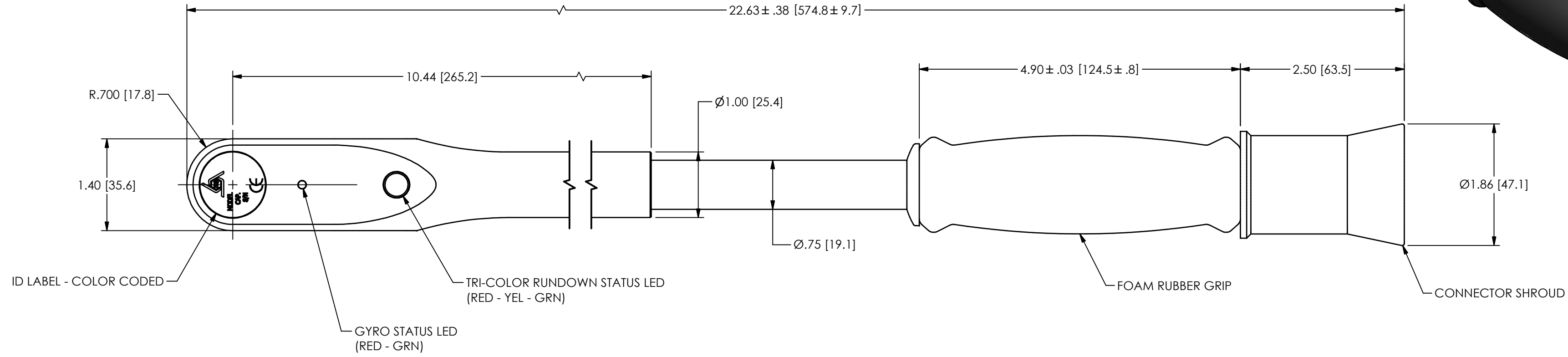
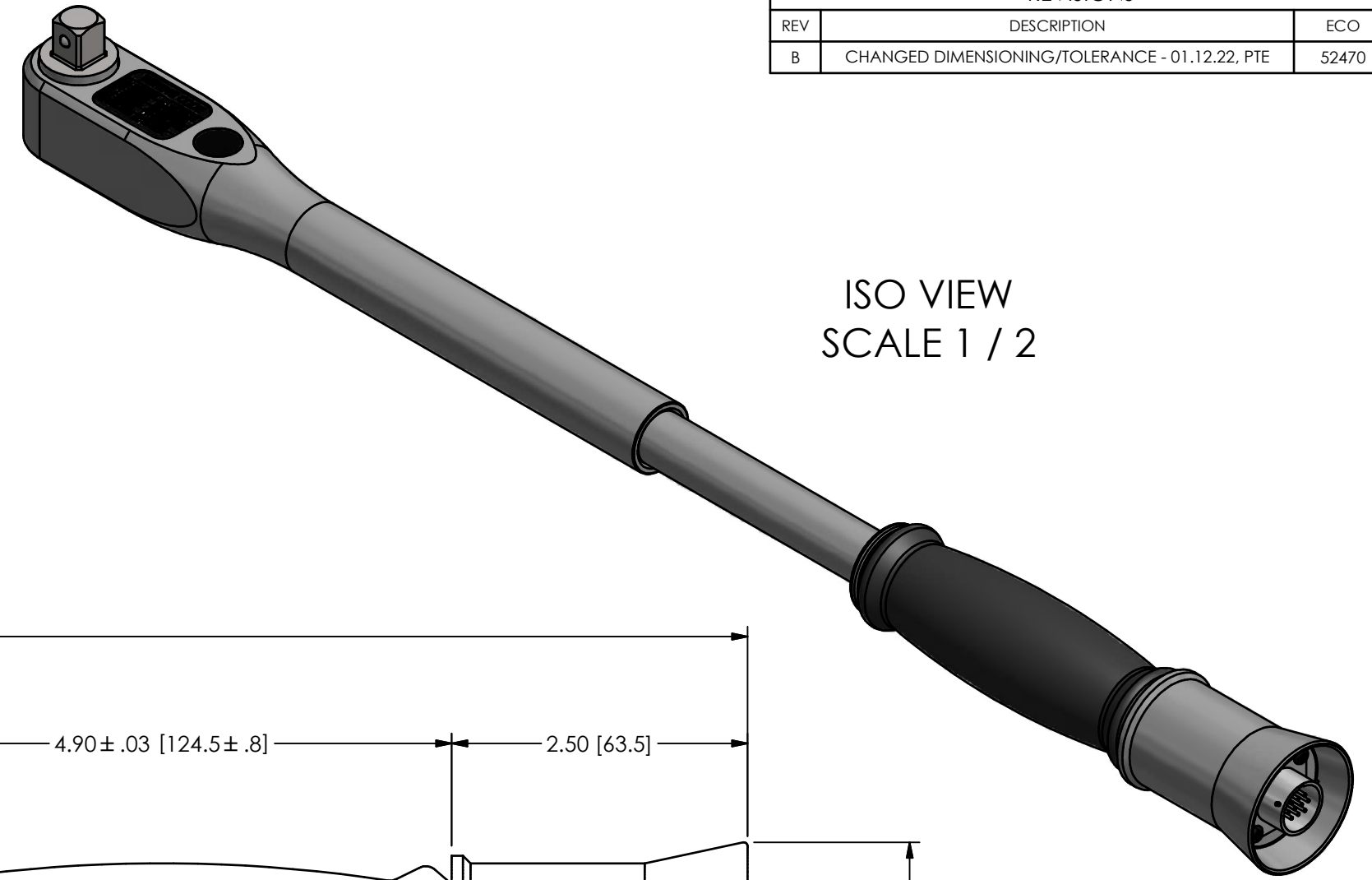

PUSH/TURN RECEPTACLE
 (PT02H-12-10P OR EQUIV.)
 WIRING CODE:
 PIN A +EXC.
 PIN B +SIG.
 PIN C -SIG.
 PIN D -EXC.
 PIN E ENCODER GND
 PIN F +5 VOLTS
 PIN G CW LEAD
 PIN H CCW TRAIL
 PIN J ID GND
 PIN K ID DATA

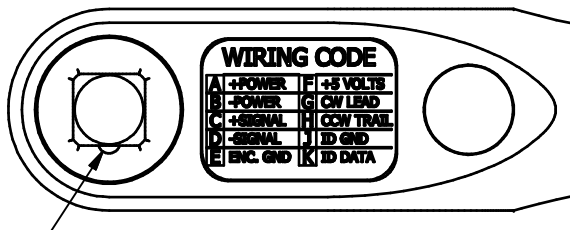

BALL DETENT

UNLESS OTHERWISE SPECIFIED TOLERANCES ARE:		DRAWN	CHECKED	ENGINEER	PCB LOAD & TORQUE A PCB GROUP COMPANY
DIMENSIONS IN INCHES	DIMENSIONS IN MILLIMETERS [IN BRACKETS]	PTE	JSD	JAM	
DECIMALS .XX ±.01 XXX ±.005	DECIMALS X ± 0.3 XX ± 0.13	TITLE			DWG. NO.
ANGLES ± .5 DEGREES	ANGLES ± .5 DEGREES	OUTLINE DRAWING 1/2" SQ DRIVE STD (027250-07XXX) HAND TORQUE/ANGLE WRENCH			50913
FILLETS AND RADII .015 MAX	FILLETS AND RADII 0.38 MAX	SCALE: 3/4			SHEET 1 OF 1