



Model 92300-063981

Run Down Adapter, Square Drive, 10-100 ft-lb (14-136 Nm), 1/2-inch Female-Male

Installation and Operating Manual

**For assistance with the operation of this product,
contact the PCB Piezotronics, Inc.**

Toll-free: 716-684-0001

24-hour SensorLine: 716-684-0001

Fax: 716-684-0987

E-mail: info@pcb.com

Web: www.pcb.com



RDA (Run Down Adapters)

These durable run down adapters (RDA) are designed to provide consistent and reliable torque readings for use with power driven torque control tools. The RDA's reduce the impact and irregular peaks that cause poor repeatability. Each RDA has an effective torque range and will supply repeatable torque data within that range if used correctly.

Operation

1. The run down adapter is mounted in-line between the tool drive and transducer.
2. The transducer should be properly secured on a solid surface or test bench.
3. Reverse RDA to relieve any pressure on the internal load washers before each rundown.
Caution: DO NOT start RDA on power tool with threads disengaged or damage may occur.
4. The RDA is designed to run clockwise direction only.
5. Apply torque until RDA is run down completely. Then note or save reading with analyzer.

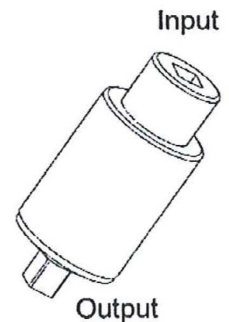

Maintenance

1. Keep the threads of the RDA well lubricated. It is recommended that the RDA be disassembled, cleaned and the threads re-coated with a molybdenum grease every 6-months. The washers, themselves do not require lubrication.

Illustrates an example of joint characteristic for RDA250i

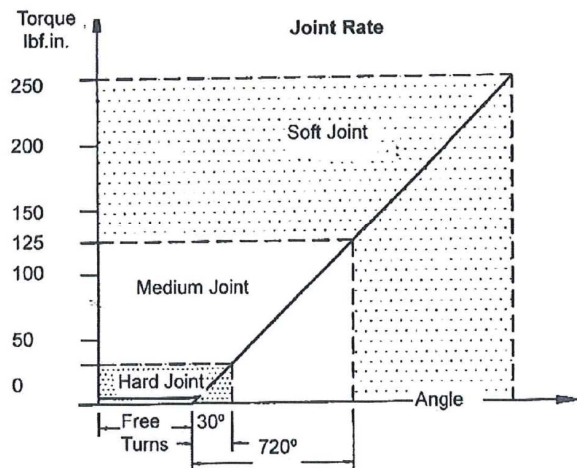

Free Turns

This is when the input drive turns freely with little or no torque. All RDA models provide at least 5 full rotations with less than 5% of nominal torque.

Hard Joint

All Mountz RDA's will simulate a hard joint rate when used below 12% of its maximum torque capacity.

Soft Joint

A soft joint rate will be achieved when RDA's are used above 50% of its maximum torque capacity.

Note: Value may vary from each model. It's recommended for you to evaluate your model whenever joint rate characteristic is critical for your test method.

Torque Test Scatter Graph

The graph on the right shows torque values recorded after each test run.

Mean Torque: 121.72 lbf.in
Standard Deviation: 11.53 lbf.in

Mountz RDAs are designed to provide minimal scattering when used with reliable and repeatable power tools, transducers and torque analyzers. The test equipment and method that are used will affect the performance of the run down adapters.

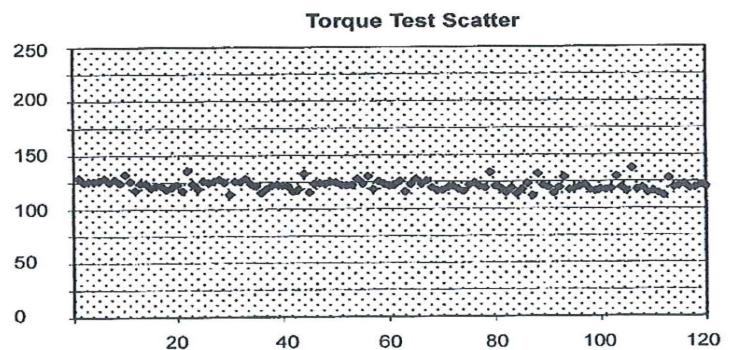

Model Number
92300-063981

RUN DOWN ADAPTOR

Revision: NR
ECN #: 35469

Performance

ENGLISH

Torque Range 10 to 100 lb-ft
Drive Size 1/2 inch Square

SI

136 to 135,6 N-m
1/2 inch Square

*All specifications are at room temperature unless otherwise specified.
In the interest of constant product improvement, we reserve the right to change specifications without notice.
ICP® is a registered trademark of PCB Group, Inc.*

OPTIONAL VERSIONS

Optional versions have identical specifications and accessories as listed for the standard model except where noted below. More than one option may be used.

Entered:	Engineer:	Sales:	Approved:	Spec Number:
Date: 8/3/11	Date: 8/3/11	Date: 8/3/11	Date: 8/3/11	51043

PCB Load & Torque, Inc.
24350 Indoplex Circle
Farmington Hills, MI 48335
UNITED STATES
Phone: 866-684-7107
Fax: 716-684-0987
E-Mail: ltinfo@pcbloadtorque.com
Web site: <http://www.pcbloadtorque.com>



2

1

PCB Load & Torque Inc. claims proprietary rights in the information disclosed hereon. Neither it nor any reproduction thereof will be disclosed to others without the written consent of PCB Load and Torque Inc.

REVISIONS

REV	DESCRIPTION	ECO
NR	RELEASED TO DRAFTING	35469

45116

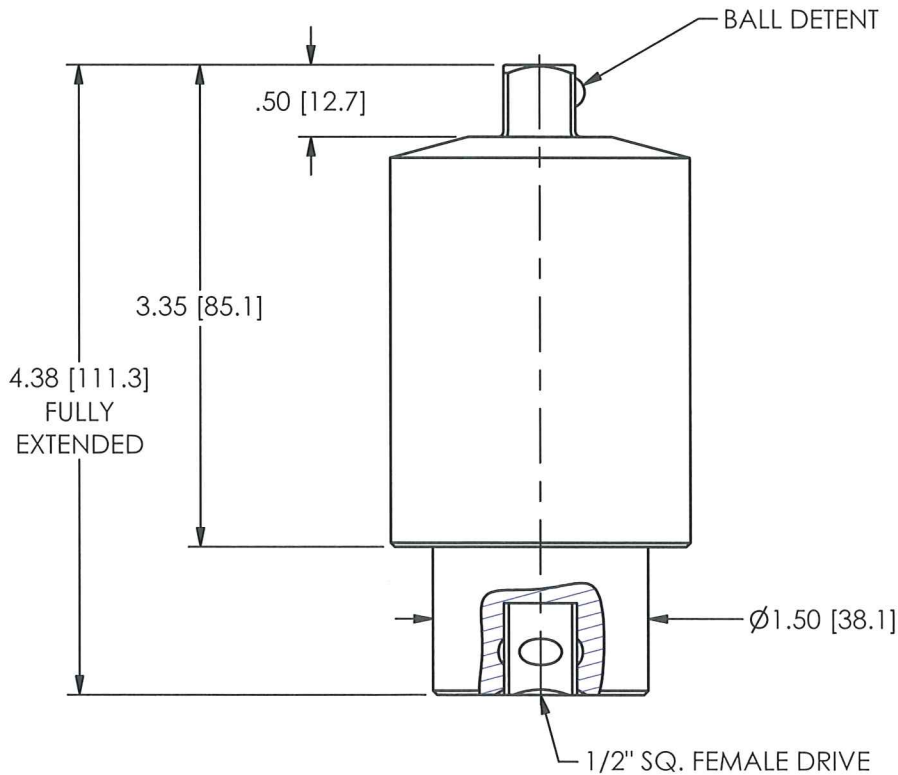
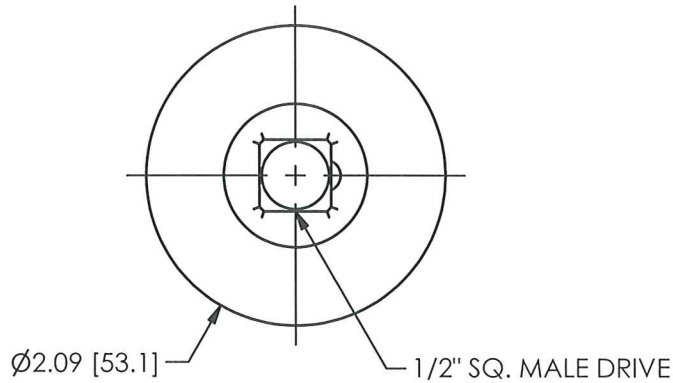

UNLESS OTHERWISE SPECIFIED TOLERANCES ARE:

DIMENSIONS IN INCHES

DIMENSIONS IN MILLIMETERS [IN BRACKETS]

DECIMALS XX ±.01
XXX ±.005

DECIMALS X ± 0.3
XX ± 0.13

ANGLES ± .5 DEGREES

ANGLES ± .5 DEGREES

FILLETS AND RADII
.015 MAX

FILLETS AND RADII
0.38 MAX

DRAWN

CHECKED

ENGINEER

smj 8/6/11 *jon 8/10/11*

PTE 8/8/11

TITLE

OUTLINE DRAWING
RUN DOWN ADAPTOR
1/2" SQ. DRIVE, 100ft-lb CAP.

PCB LOAD & TORQUE
A PCB GROUP COMPANY

24350 Indoplex Circle, Farmington Hills, MI 48335
(716) 684-0001 E-MAIL: llinfo@pcbloadtorque.com

DWG. NO.

45116

SCALE: 3/4

SHEET 1 OF 1

2

1

1

Repair and Maintenance

PCB guarantees Total Customer Satisfaction through its “Lifetime Warranty Plus” on all Platinum Stock Products sold by PCB and through its limited warranties on all other PCB Stock, Standard and Special products. Due to the sophisticated nature of our sensors and associated instrumentation, **field servicing and repair is not recommended and, if attempted, will void the factory warranty.**

Beyond routine calibration and battery replacements where applicable, our products require no user maintenance. Clean electrical connectors, housings, and mounting surfaces with solutions and techniques that will not harm the material of construction. Observe caution when using liquids near devices that are not hermetically sealed. Such devices should only be wiped with a dampened cloth—never saturated or submerged.

In the event that equipment becomes damaged or ceases to operate, our Application Engineers are here to support your troubleshooting efforts 24 hours a day, 7 days a week. Call or email with model and serial number as well as a brief description of the problem.

Calibration

Routine calibration of sensors and associated instrumentation is necessary to maintain measurement accuracy. We recommend calibrating on an annual basis, after exposure to any extreme environmental influence, or prior to any critical test.

PCB Piezotronics is an ISO-9001 certified company whose calibration services are accredited by A2LA to ISO/IEC 17025, with full traceability to SI through N.I.S.T. In addition to our standard calibration services, we also offer specialized tests, including: sensitivity at elevated or cryogenic temperatures, phase response, extended high or low frequency response, extended range, leak testing, hydrostatic pressure testing, and others. For more information, contact your local PCB Piezotronics distributor, sales representative, or factory customer service representative.

Returning Equipment

If factory repair is required, our representatives will provide you with a Return Material Authorization (RMA) number, which we use to reference any information you have already provided and expedite the repair process. This number should be clearly marked on the outside of all returned package(s) and on any packing list(s) accompanying the shipment.

Contact Information

PCB Piezotronics, Inc.
3425 Walden Ave.
Depew, NY14043 USA
Toll-free: (800) 828-8840
24-hour SensorLine: (716) 684-0001
General inquiries: info@pcb.com
Repair inquiries: rma@pcb.com

For a complete list of distributors, global offices and sales representatives, visit our website, www.pcb.com.

Safety Considerations

This product is intended for use by qualified personnel who recognize shock hazards and are familiar with the precautions required to avoid injury. While our equipment is designed with user safety in mind, the protection provided by the equipment may be impaired if equipment is used in a manner not specified by this manual.

Discontinue use and contact our 24-Hour Sensorline if:

- Assistance is needed to safely operate equipment
- Damage is visible or suspected
- Equipment fails or malfunctions

For complete equipment ratings, refer to the enclosed specification sheet for your product.

Definition of Terms and Symbols

The following symbols may be used in this manual:



DANGER

Indicates an immediate hazardous situation, which, if not avoided, may result in death or serious injury.

**CAUTION**

Refers to hazards that could damage the instrument.

**NOTE**

Indicates tips, recommendations and important information. The notes simplify processes and contain additional information on particular operating steps.

The following symbols may be found on the equipment described in this manual:



This symbol on the unit indicates that high voltage may be present. Use standard safety precautions to avoid personal contact with this voltage.



This symbol on the unit indicates that the user should refer to the operating instructions located in the manual.



This symbol indicates safety, earth ground.

PCB- PCB工业监测和测量设备 - 中国RoHS 公布表
PCB Industrial Monitoring and Measuring Equipment - China RoHS Disclosure Table

部件名称 Part Name	有毒和危险品 Toxic and Hazardous Substances or Elements									
	铅 (Pb)	水银 (Hg)	镉 (Cd)	六价 铬 (Cr(VI))	多溴化 苯 (PBB)	多溴化二苯 醚 (PBDE)	邻苯二甲酸 二(2-乙基) 己酯 (DEHP)	邻苯二甲丁 基苯酯 (BBP)	邻苯二甲酸 二酸正丁酯 (DBP)	邻苯二甲酸 二异丁酯 (DIBP)
电气外壳 (Electrical Enclosures)	X	○	○	○	○	○	○	○	○	○
紧固件和弹簧 (Fasteners)	X	○	○	○	○	○	○	○	○	○
电缆组件 (Cable Assembly)	X	○	○	○	○	○	○	○	○	○
印刷电路板组装 (PCBAs)	X	○	○	○	○	○	○	○	○	○
机械零件(Mechanical Parts)	○	○	○	○	○	○	○	○	○	○
塑料和橡胶零件 (Plastic & Rubber Parts)	○	○	○	○	○	○	○	○	○	○
金属零件 (Metal Parts)	X	○	○	○	○	○	○	○	○	○

本表格依据 SJ/T 11364 的规定编制

○ =表示该有害物质在该部件所有均质材料中的含量均在 GB/T 26572 规定的限量要求以下 (indicates that the content of the toxic and hazardous substance in all the Homogeneous Materials of the part is below the concentration limit requirement as described in GB/T 26572).

X =表示该有害物质至少在该部件的某一均质材料中的含量超出 GB/T 26572 规定的限量要求 (indicates that the content of the toxic and hazardous substance in at least one Homogeneous Material of the part exceeds the concentration limit requirement as described in GB/T 26572).