



**Model 92300-063977**

**Run Down Adapter, Square Drive, 75-750 in-lb (8.4-84.8 Nm), 3/8-inch Female-Male**

**Installation and Operating Manual**

**For assistance with the operation of this product,  
contact the PCB Piezotronics, Inc.**

**Toll-free: 716-684-0001**

**24-hour SensorLine: 716-684-0001**

**Fax: 716-684-0987**

**E-mail: [info@pcb.com](mailto:info@pcb.com)**

**Web: [www.pcb.com](http://www.pcb.com)**



## RDA (Run Down Adapters)

These durable run down adapters (RDA) are designed to provide consistent and reliable torque readings for use with power driven torque control tools. The RDA's reduce the impact and irregular peaks that cause poor repeatability. Each RDA has an effective torque range and will supply repeatable torque data within that range if used correctly.

### Operation

1. The run down adapter is mounted in-line between the tool drive and transducer.
2. The transducer should be properly secured on a solid surface or test bench.
3. Reverse RDA to relieve any pressure on the internal load washers before each rundown.  
**Caution:** DO NOT start RDA on power tool with threads disengaged or damage may occur.
4. The RDA is designed to run clockwise direction only.
5. Apply torque until RDA is run down completely. Then note or save reading with analyzer.

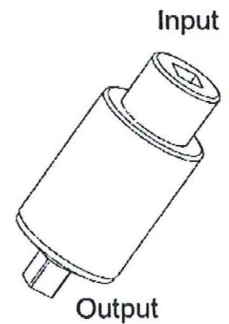

### Maintenance

1. Keep the threads of the RDA well lubricated. It is recommended that the RDA be disassembled, cleaned and the threads re-coated with a molybdenum grease every 6-months. The washers, themselves do not require lubrication.

Illustrates an example of joint characteristic for RDA250i

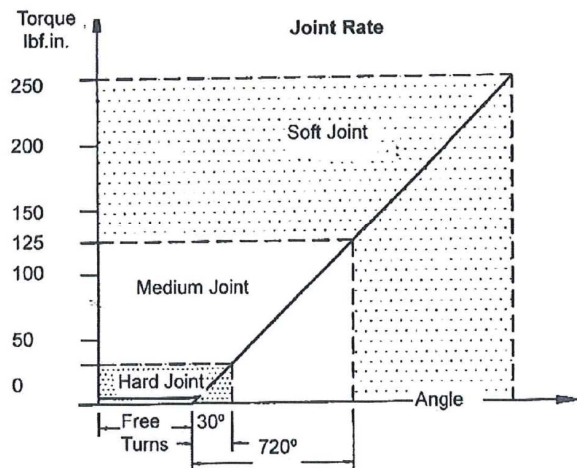

#### Free Turns

This is when the input drive turns freely with little or no torque. All RDA models provide at least 5 full rotations with less than 5% of nominal torque.

#### Hard Joint

All Mountz RDA's will simulate a hard joint rate when used below 12% of its maximum torque capacity.

#### Soft Joint

A soft joint rate will be achieved when RDA's are used above 50% of its maximum torque capacity.

**Note:** Value may vary from each model. It's recommended for you to evaluate your model whenever joint rate characteristic is critical for your test method.

### Torque Test Scatter Graph

The graph on the right shows torque values recorded after each test run.

Mean Torque: 121.72 lbf.in  
 Standard Deviation: 11.53 lbf.in

Mountz RDAs are designed to provide minimal scattering when used with reliable and repeatable power tools, transducers and torque analyzers. The test equipment and method that are used will affect the performance of the run down adapters.

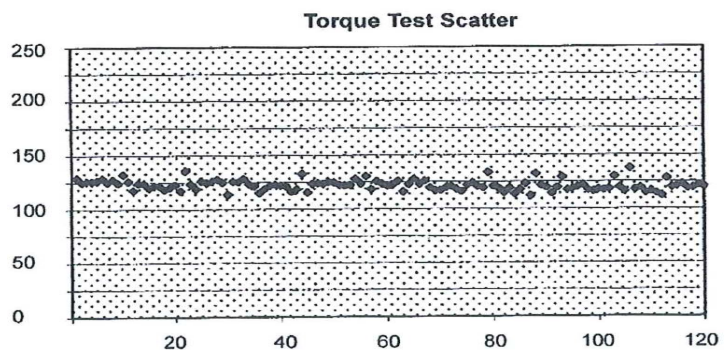

Model Number  
92300-063977

# RUN DOWN ADAPTOR

Revision: NR  
ECN #: 35499

**Performance**  
Torque Range  
Drive Size

**ENGLISH**  
75 to 750 lb/in  
3/8 inch Square

**SI**  
847 to 8473 cN-m  
3/8 inch Square

*All specifications are at room temperature unless otherwise specified.  
In the interest of constant product improvement, we reserve the right to change specifications without notice.  
ICP® is a registered trademark of PCB Group, Inc.*

### OPTIONAL VERSIONS

Optional versions have identical specifications and accessories as listed for the standard model except where noted below. More than one option may be used.

Entered:	Engineer:	Sales:	Approved:	Spec Number:
Date: 8/3/11	Date: 8/3/11	Date: 8/3/11	Date: 8/3/11	51041



PCB Load & Torque, Inc.  
24350 Indoplex Circle  
Farmington Hills, MI 48335  
UNITED STATES  
Phone: 866-684-7107  
Fax: 716-684-0987  
E-Mail: [hintoo@pcbloadtorque.com](mailto:hintoo@pcbloadtorque.com)  
Web site: <http://www.pcbloadtorque.com>

2

1

PCB Load & Torque Inc. claims proprietary rights in the information disclosed hereon. Neither it nor any reproduction thereof will be disclosed to others without the written consent of PCB Load and Torque Inc.

REVISIONS

REV	DESCRIPTION	ECO
NR	RELEASED TO DRAFTING	35469

45115

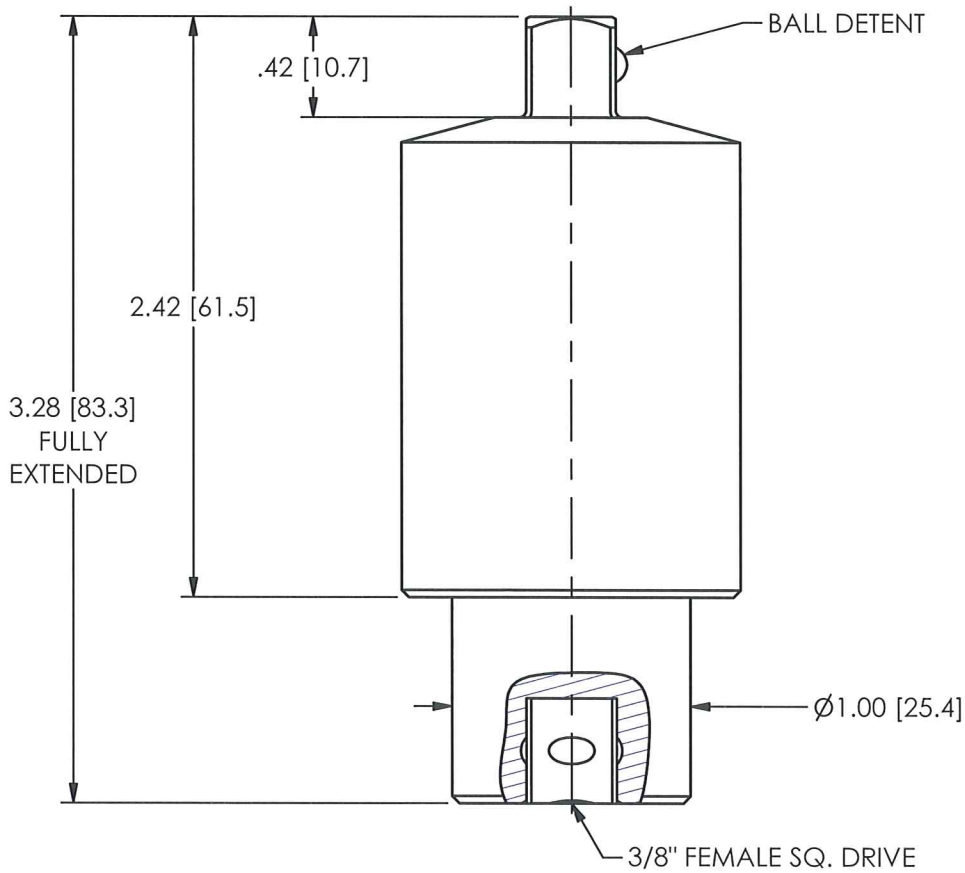
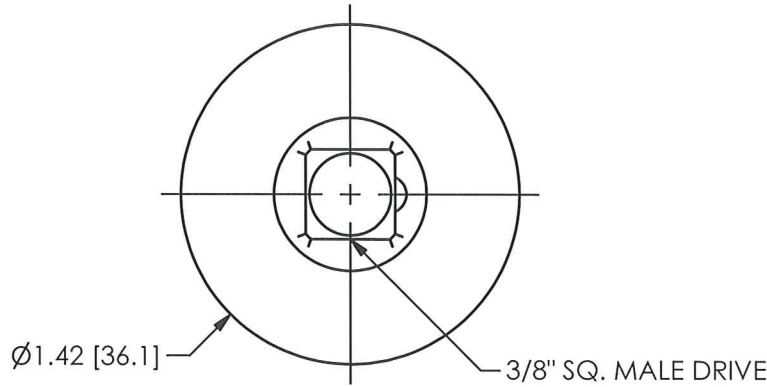

UNLESS OTHERWISE SPECIFIED TOLERANCES ARE:		DRAWN	CHECKED	ENGINEER	 <b>PCB LOAD &amp; TORQUE</b> A PCB GROUP COMPANY
DIMENSIONS IN INCHES	DIMENSIONS IN MILLIMETERS [IN BRACKETS]	<i>Sam B</i>	<i>John</i>	PTE	
DECIMALS XX $\pm 0.01$ XXX $\pm 0.005$	DECIMALS X $\pm 0.3$ XX $\pm 0.13$	TITLE			DWG. NO.
ANGLES $\pm .5$ DEGREES	ANGLES $\pm .5$ DEGREES	OUTLINE DRAWING RUN DOWN ADAPTOR 3/8" SQ. DRIVE, 750in-lb & 50ft-lb CAP.			45115
FILLETS AND RADII .015 MAX	FILLETS AND RADII 0.38 MAX				SCALE: 1.25X SHEET 1 OF 1

2

1