



MODELS  
(EX)649A01 & (EX)649A71

## RECIPROCATING MACHINERY PROTECTOR (RMP)

- Outperforms impact transmitters by providing earlier warnings of mechanical looseness and faults, including loose/broken bolts/rod nuts, cracked rods and cylinder debris.
- Provides peak acceleration output signal when no impacts are detected above the threshold levels.
- Counts impacts based on two threshold levels with their own independent weightings.
- Incorporates dead time after initial impact where peaks are not counted to prevent false counts.
- Offers electronically-configurable time window, peak acceleration range, threshold levels and weightings.
- Program with optional USB programmer kit (Model 600A35).



### FOR MONITORING RECIPROCATING COMPRESSORS AND OTHER RECIPROCATING MACHINERY

Reciprocating machinery faults typically manifest themselves as high frequency, high amplitude impacts. While simple to integrate with PLCs for continuous monitoring, standard vibration transmitters with a current output aren't ideal for identifying their impacts because, in the conversion of AC voltage to DC voltage via the RMS process, signal peaks are smoothed out and have little effect on the resulting overall vibration level. By the time that a vibration transmitter would signal a problem, equipment damage would have already occurred.

The patented Reciprocating Machinery Protector (US Patent No. 7, 171, 313) offers the best of both worlds by providing a 4-20 mA current output that is reflective of the number of high-frequency, high-amplitude impacts occurring. The output is calculated by counting the number of short, high-amplitude impacts, comparing them to field-adjustable vibration threshold levels and weighting them accordingly. This process allows the resulting output to indicate a problem and prompt a technician to take corrective measures before the fault becomes catastrophic.

SPECIFICATIONS		
Model Number	(EX)649A01	(EX)649A71
<b>Performance</b>		
Output	4-20 mA	
Machinery Frequency Range	240 to 10,000 RPM 4-166 Hz	
Time Window	0.1 - 4.0 sec	
Trending Current Range	4-20 mA	
Lower Threshold Level	2 - 50 g	
Upper Threshold Level	2 - 50 g	
Lower Weighting	0.2 - 16 mA in 0.2 mA increments	
Upper Weighting	0.2 - 16 mA in 0.2 mA increments	
<b>Environmental</b>		
Overload Limit (Shock)	5,000 g pk 49,050 m/s <sup>2</sup> pk	
Operating Temperature Range	-40 to +212 °F -40 to +100 °C	
Hazardous Area Approval	ATEX and CSA (EX prefix only)	
<b>Electrical</b>		
Excitation Voltage	15-30 VDC	
Maximum Load Resistance	50 (Vs-15) ohm	
Electrical Isolation	>10 <sup>8</sup> ohm	
<b>Physical</b>		
Housing Material	Stainless Steel	
Sealing	Welded Hermetic	
Mounting Thread	1/4-28 Female	1/4 NPT Male
Mounting Torque	3 to 5 ft-lb	N/A
	4 to 7 N-m	N/A
Electrical Connector	2-pin MIL-C-5015	Terminal Block
Electrical Connection A	4-20 mA Pos (+)	4-20 mA Pos (+)
Electrical Connections B	4-20 mA Neg (-)	4-20 mA Neg (-)
Size (Hex x Height)	1.25 x 2.60 in	5.80 x 3.85 in
	32 x 66 mm	147 x 98 mm
Weight	7.0 oz	17.6 oz
	198 gm	500 gm

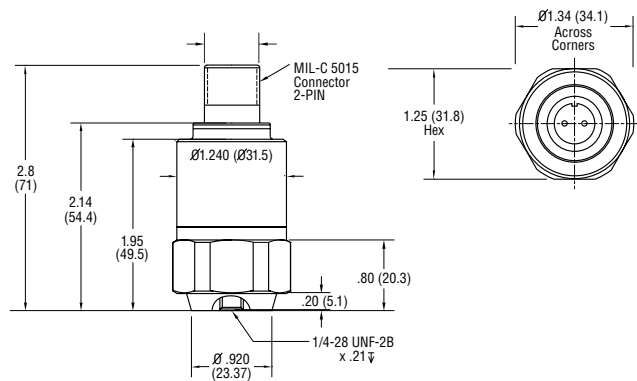

**Models (EX)649A01**

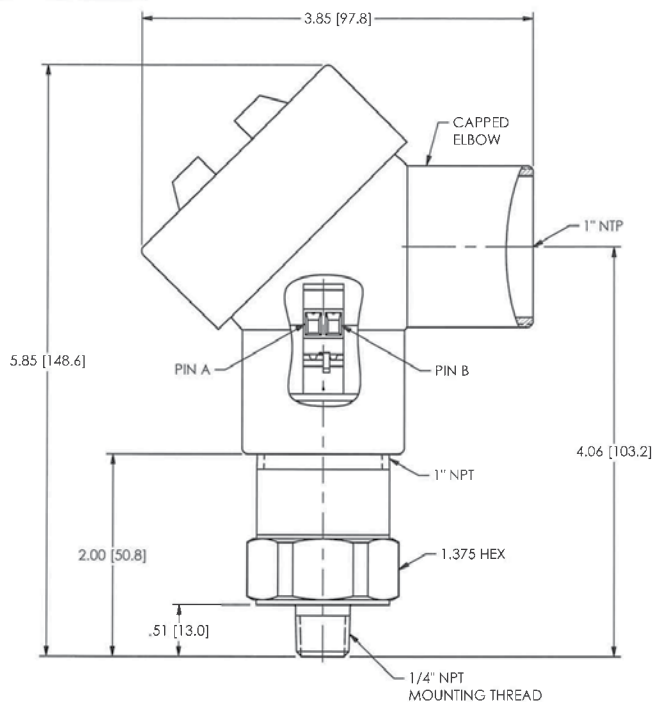

**Models (EX)649A71**



3425 Walden Avenue, Depew, NY 14043-2495 USA

Toll-Free in the USA: 1 800 959 4464

Phone: 1 716 684 0003 | Email: imi@pcb.com

IMI Sensors, a division of PCB Piezotronics, Inc. manufactures industrial vibration monitoring instrumentation, such as accelerometers, vibration transmitters and switches that feature rugged stainless steel housings and survive in harsh environments like paper and steel mills, mines, gas turbines, water treatment facilities and power plants. Integrating with portable analyzers and PLC's, IMI instrumentation helps maintenance departments reduce downtime and protect critical machinery. Visit IMI Sensors at [www.pcb.com](http://www.pcb.com). PCB Piezotronics, Inc. is a wholly owned subsidiary of MTS Systems Corporation. Additional information on MTS can be found at [www.mts.com](http://www.mts.com).

© 2019 PCB Piezotronics, Inc. In the interest of constant product improvement, specifications are subject to change without notice. PCB®, ICP®, Swiveler®, Modally Tuned®, and IMI® with associated logo are registered trademarks of PCB Piezotronics, Inc. in the United States. ICP® is a registered trademark of PCB Piezotronics Europe GmbH in Germany and other countries. UHT-12™ is a trademark of PCB Piezotronics, Inc. SensorLine™ is a service mark of PCB Piezotronics, Inc. SWIFT® is a registered trademark of MTS Systems Corporation in the United States.



MTS Sensors, a division of MTS Systems Corporation (NASDAQ: MTSC), vastly expanded its range of products and solutions after MTS acquired PCB Piezotronics, Inc. in July, 2016. PCB Piezotronics, Inc. is a wholly owned subsidiary of MTS Systems Corp.; IMI Sensors and Larson Davis are divisions of PCB Piezotronics, Inc.; Accumetrics, Inc. and The Modal Shop, Inc. are subsidiaries of PCB Piezotronics, Inc.