

PCB Piezotronics Inc. claims proprietary rights in the information disclosed hereon. Neither it nor any reproduction thereof will be disclosed to others without the written consent of PCB Piezotronics Inc.

66280

| REVISIONS | | |
|-----------|----------------------|-------|
| REV | DESCRIPTION | DIN |
| NR | RELEASED TO DRAFTING | 46819 |

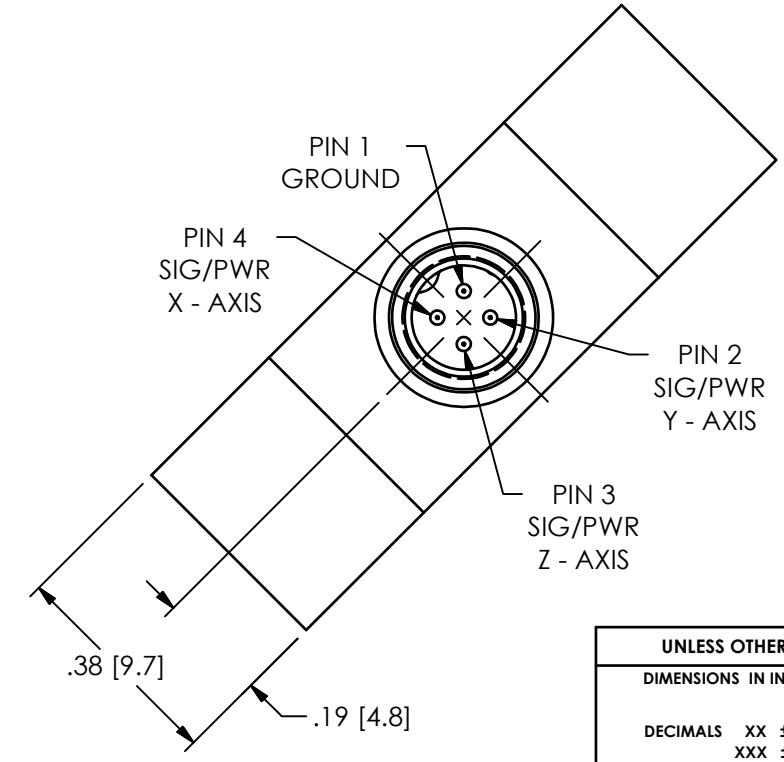
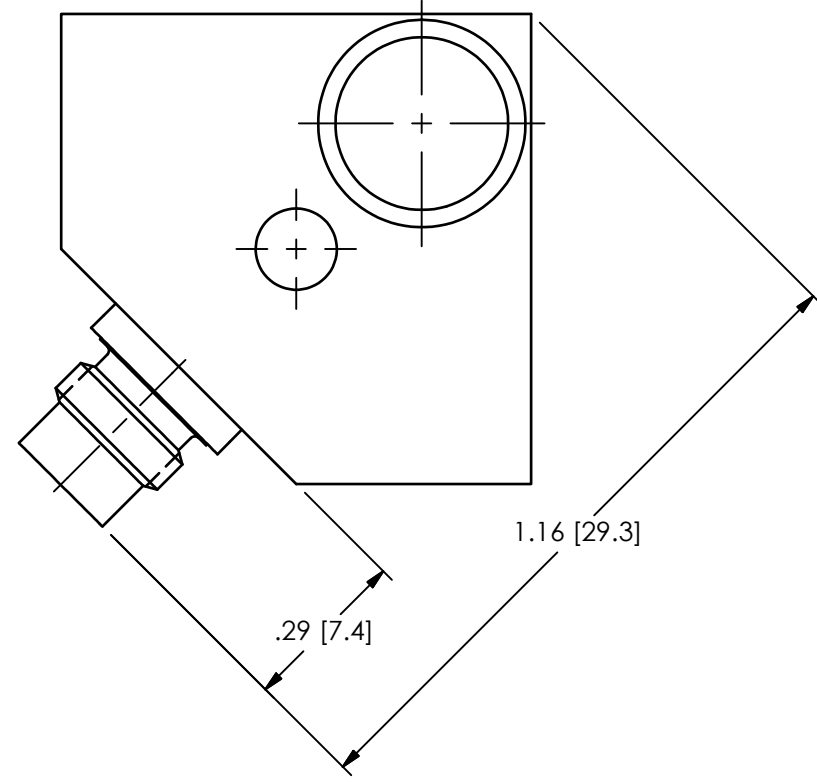
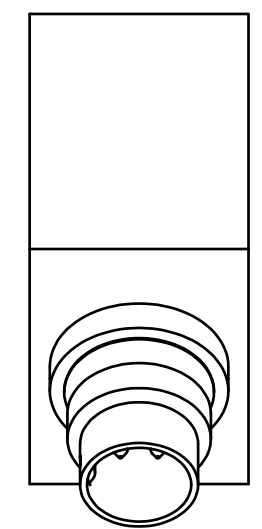
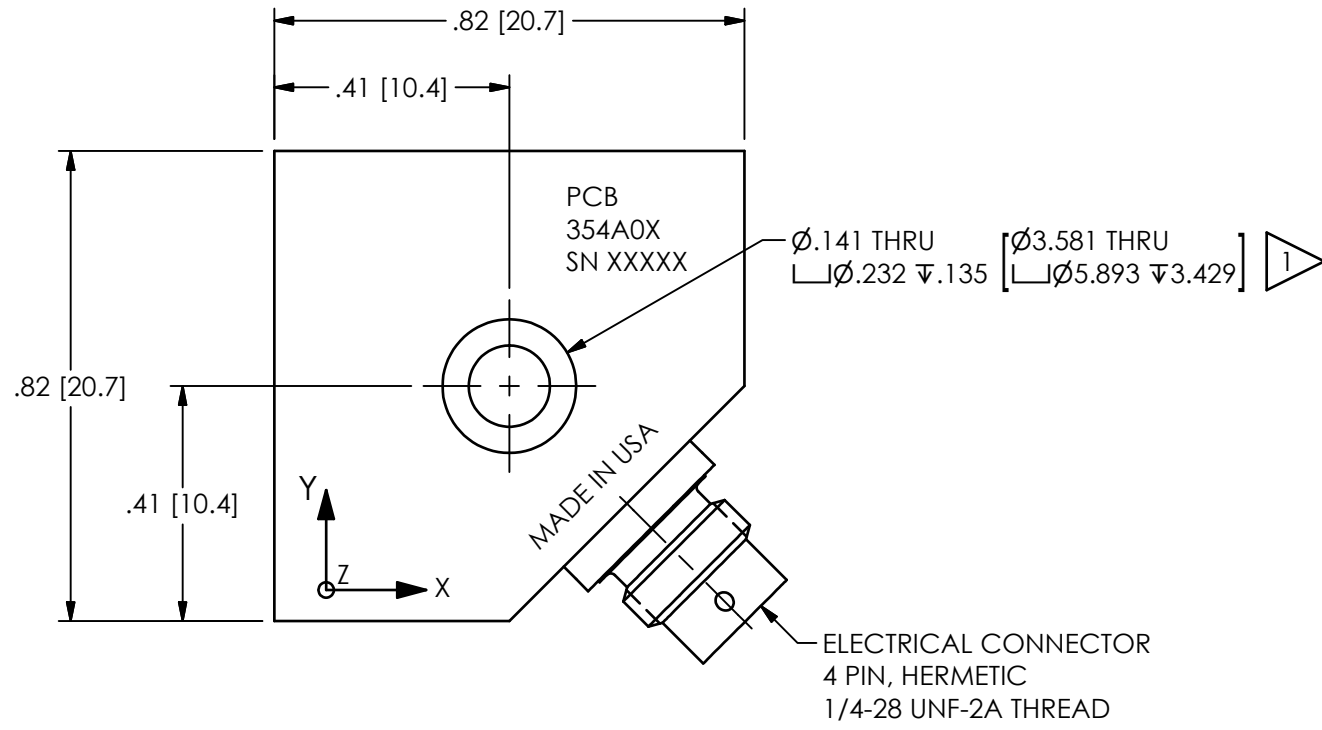

1 6-32 MOUNTING CAP SCREW INCLUDED (081A105)

| UNLESS OTHERWISE SPECIFIED TOLERANCES ARE: | | DRAWN | | CHECKED | | ENGINEER | |
|--|---|--|---------|-------------------|---------|--|---------|
| DIMENSIONS IN INCHES | DIMENSIONS IN MILLIMETERS [IN BRACKETS] | JDM | 5/18/17 | JDM | 5/18/17 | JJD | 5/18/17 |
| DECIMALS XX ±.03 XXX ±.010 | DECIMALS X ±0.8 XX ±0.25 | TITLE OUTLINE DRAWING MODEL 354A0X | | | | | |
| ANGLES ± 2 DEGREES | ANGLES ± 2 DEGREES | | | | | | |
| FILLETS AND RADII .003 - .005 | FILLETS AND RADII 0.07 - 0.13 | CODE IDENT. NO. 52681 | | DWG. NO. 66280 | | 3425 WALDEN AVE. DEPEW, NY 14043 (716) 684-0001 E-MAIL: sales@pcb.com | |
| | | SCALE: 3X | | SHEET 1 OF 1 | | | |

PCB PIEZOTRONICS™

3425 WALDEN AVE. DEPEW, NY 14043
(716) 684-0001 E-MAIL: sales@pcb.com

CODE IDENT. NO. 52681
DWG. NO. 66280

SCALE: 3X SHEET 1 OF 1