

PCB Piezotronics Inc. claims proprietary rights in the information disclosed hereon. Neither it nor any reproduction thereof will be disclosed to others without the written consent of PCB Piezotronics Inc.

52262

REVISIONS		
REV	DESCRIPTION	DIN
B	MOUNTING HOLE PREP: 5.3 WAS 5.9	46415

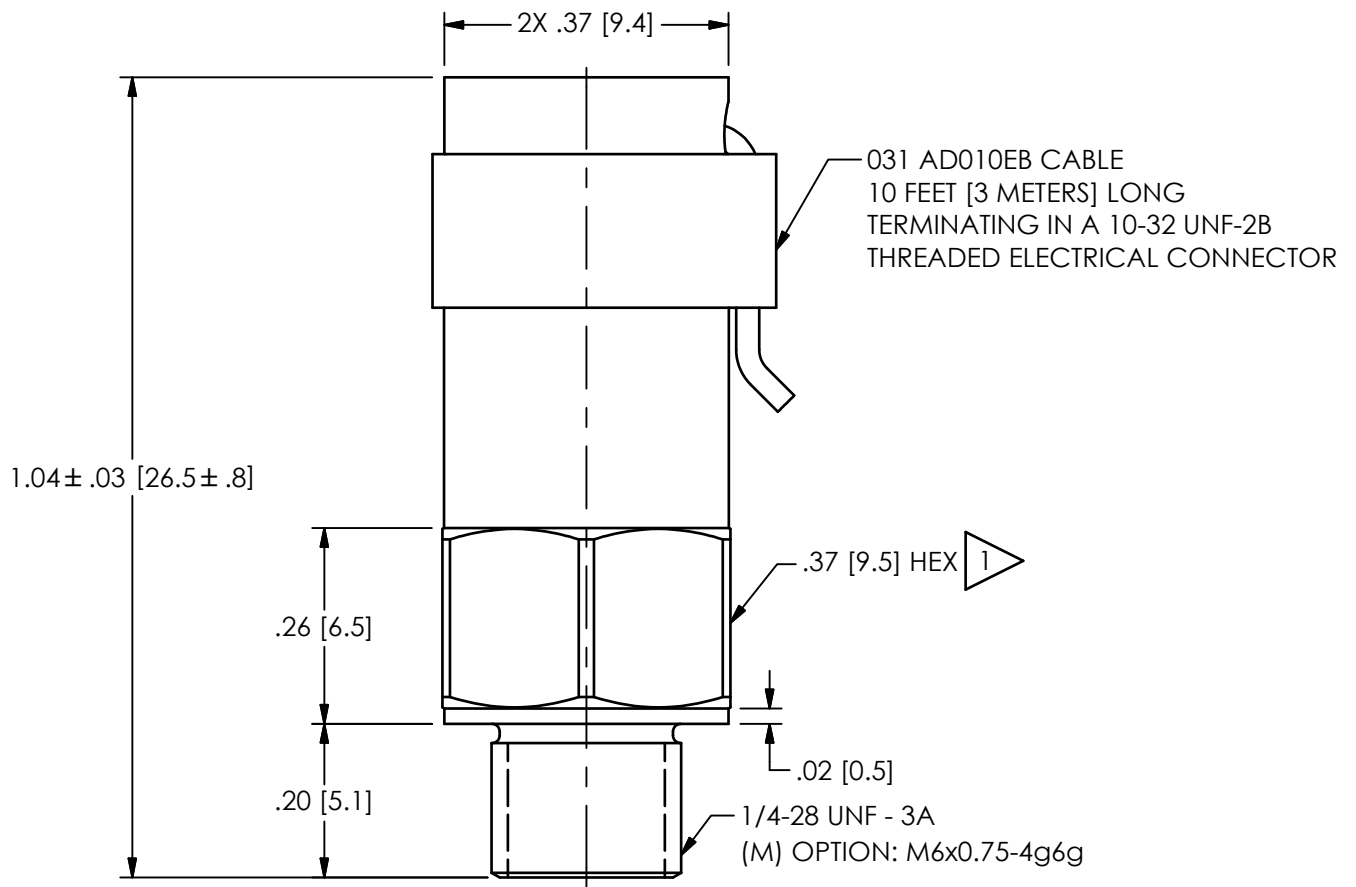

MOUNTING HOLE PREPARATION
 Ø.22 [5.4] ∇ .30 [7.6] MIN
 1/4-28 UNF-3B ∇ .20 [5.1] MIN

(M) OPTION
 Ø.21 [5.3] ∇ .30 [7.6] MIN
 M6 X 0.75-6H ∇ .20 [5.1] MIN

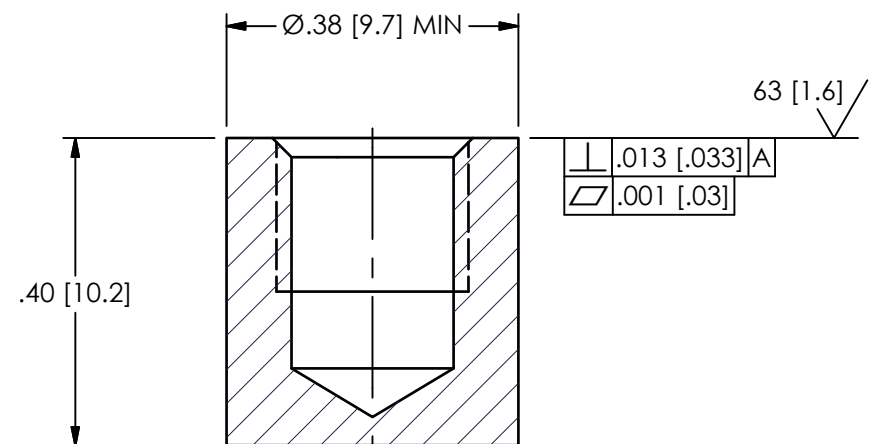

1 RECOMMENDED MOUNTING TORQUE ON .37 [.95] HEX 2.5-4 ft lbs [2.8-3.4 Nm]

UNLESS OTHERWISE SPECIFIED TOLERANCES ARE:		DRAWN		CHECKED		ENGINEER	
DIMENSIONS IN INCHES	DIMENSIONS IN MILLIMETERS [IN BRACKETS]	KRM	1/31/17	ECB	1/31/17	BAM	1/31/17
DECIMALS XX ±.01 XXX ±.005	DECIMALS X ±.03 XX ±.013	TITLE INSTALLATION DRAWING MECHANICALLY FILTERED SHOCK ACCELEROMETER					
ANGLES ± 2 DEGREES	ANGLES ± 2 DEGREES						
FILLETS AND RADII .003 - .005	FILLETS AND RADII 0.07 - 0.13	CODE IDENT. NO. 52681		DWG. NO. 52262		SCALE: 4X SHEET 1 OF 1	

PCB PIEZOTRONICS™
 3425 WALDEN AVE. DEPEW, NY 14043
 (716) 684-0001 E-MAIL: sales@pcb.com