

112-1040-90

PCB Piezotronics Inc. claims proprietary rights in the information disclosed hereon. Neither it nor any reproduction thereof will be disclosed to others without the written consent of PCB Piezotronics Inc.

REVISIONS		
REV	DESCRIPTION	DIN
L	MADE DIMENSION 1.57 REFERENCE	39207

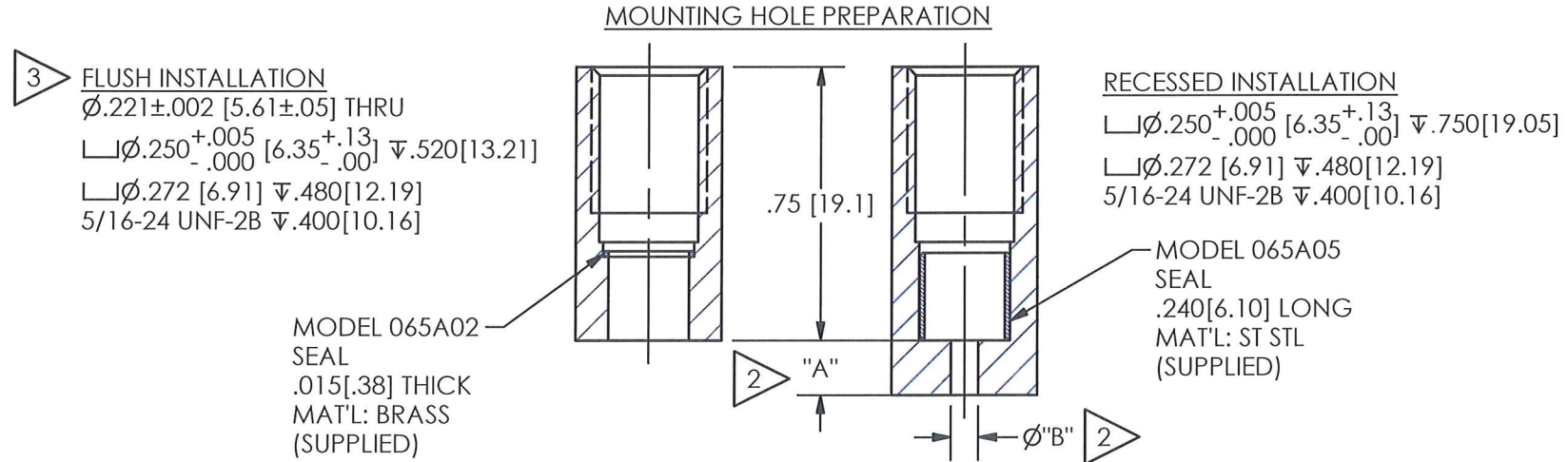
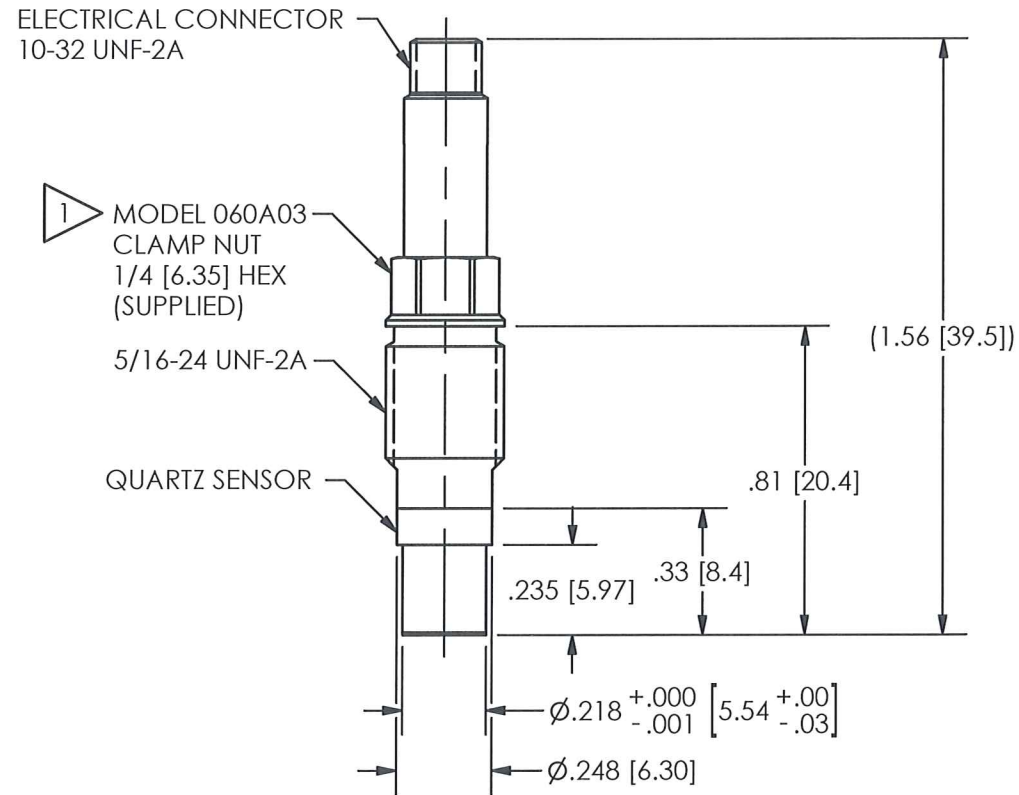

- 3 THESE DIMENSIONS FOR .75[.19.0] THICK WALL. \perp THICKER WALLS TO THIS DIMENSION.
- 2 DIMENSIONS "A" AND ϕ "B" TO SUIT USER REQUIREMENTS.
- 1 RECOMMENDED TORQUE ON CLAMP NUT 25-35 INCH POUNDS [225-395 Ncm].

UNLESS OTHERWISE SPECIFIED TOLERANCES ARE:		DRAWN		CHECKED		ENGINEER	
DIMENSIONS IN INCHES	DIMENSIONS IN MILLIMETERS [IN BRACKETS]	JDM	5/3/12	ECB	5/3/12	SMB	5/3/12
DECIMALS XX ±.01 XXX ±.005	DECIMALS X ±.03 XX ±.013	TITLE					
ANGLES ± 2 DEGREES	ANGLES ± 2 DEGREES	INSTALLATION DRAWING MODELS 112A04 & 112A05 HERMETIC SEALED PRESSURE SENSORS					
FILLETS AND RADII .003 - .005	FILLETS AND RADII 0.07 - 0.13	CODE IDENT. NO. 52681		DWG. NO. 112-1040-90			
		SCALE: 2X		SHEET 1 OF 1			

PCB PIEZOTRONICS
 3425 WALDEN AVE. DEPEW, NY 14043
 (716) 684-0001 E-MAIL: sales@pcb.com