

LT30776

PCB Load & Torque Inc. claims proprietary rights in the information disclosed herein. Neither it nor any reproduction thereof will be disclosed to others without the written consent of PCB Load and Torque Inc.

REVISIONS		
REV	DESCRIPTION	ECO
E	ADDED CABLE OPTIONS - 03.20.17, PTE	46633

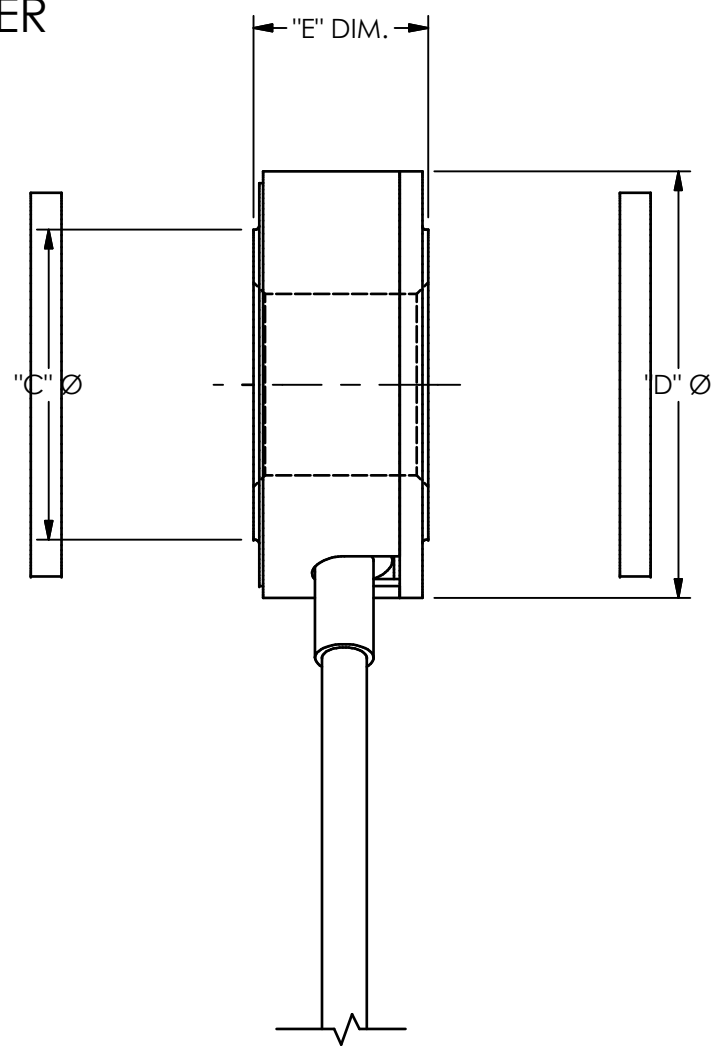
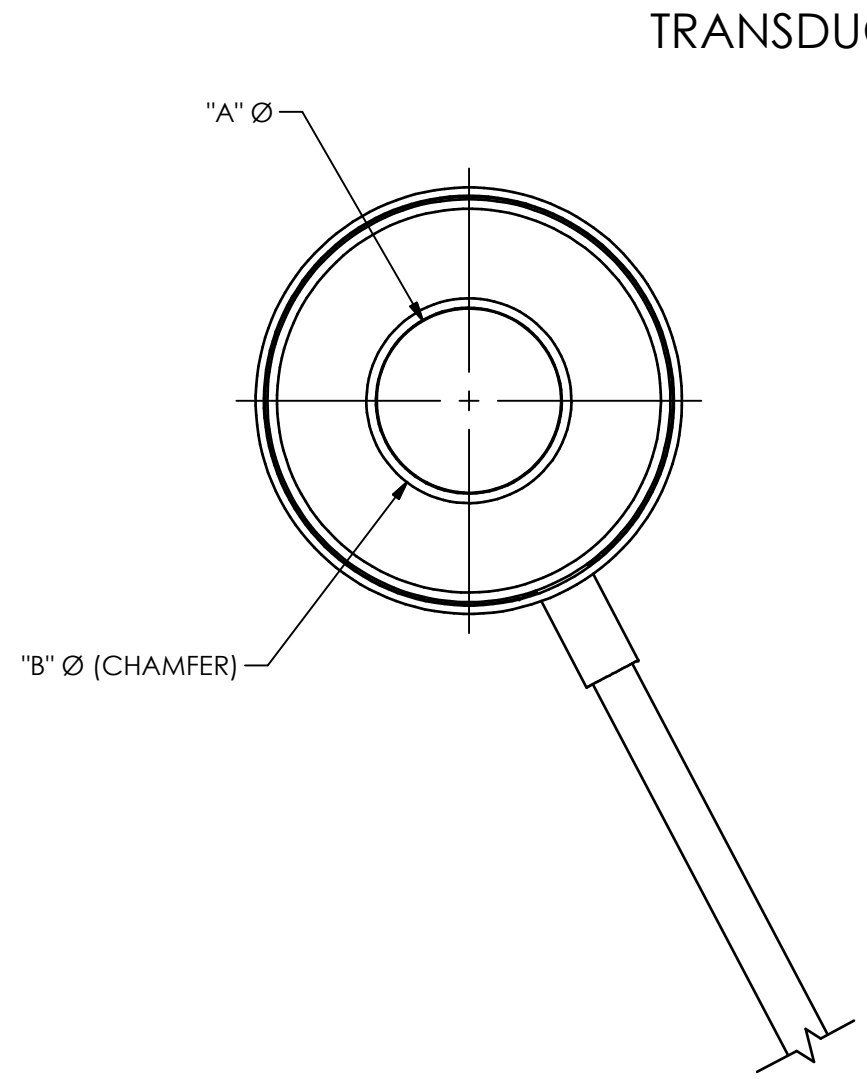
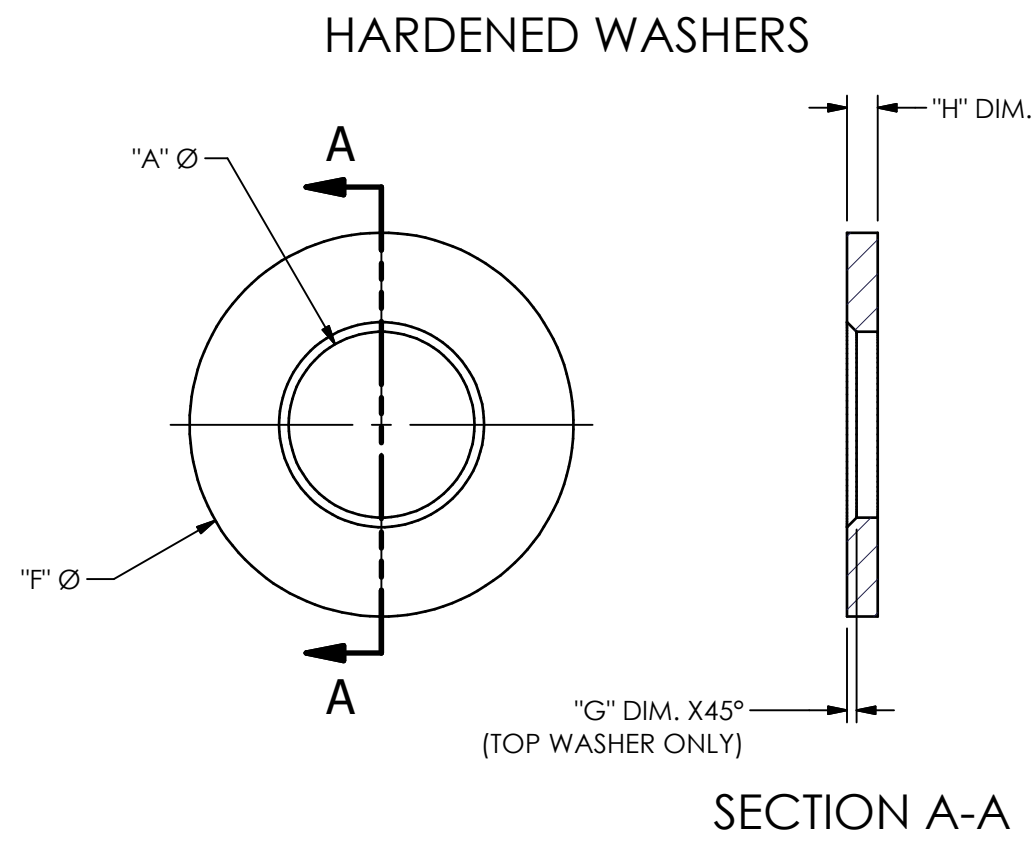

ENGLISH SERIES - DIMENSIONS IN INCHES

PART NO.	BOLT SIZE	CAPACITY	"A"	"B"	"C"	"D"	"E"	"F"	"G"	"H"
054103-01252	#10	2,500 LBF	0.196	0.224	0.308	0.682	0.255	0.375	0.014	0.050
054104-01502	1/4"	5,000 LBF	0.256	0.284	0.400	0.674	0.255	0.500	0.014	0.050
054105-01802	5/16"	8,000 LBF	0.319	0.353	0.501	0.809	0.317	0.625	0.017	0.050
054106-01103	3/8"	10K LBF	0.381	0.421	0.612	0.842	0.380	0.750	0.020	0.050
054107-01153	7/16"	15K LBF	0.433	0.485	0.703	0.943	0.420	0.875	0.022	0.080
054108-01203	1/2"	20K LBF	0.506	0.557	0.806	1.111	0.455	1.000	0.026	0.080
054109-01253	9/16"	25K LBF	0.569	0.628	0.909	1.213	0.495	1.125	0.028	0.080
054110-01303	5/8"	30K LBF	0.631	0.695	1.013	1.348	0.525	1.250	0.032	0.125
054112-01403	3/4"	40K LBF	0.756	0.828	1.222	1.618	0.595	1.500	0.037	0.125
054114-01603	7/8"	60K LBF	0.881	0.965	1.431	1.888	0.665	1.750	0.042	0.125
054116-01803	1"	80K LBF	1.006	1.100	1.640	2.158	0.735	2.000	0.047	0.125

METRIC SERIES - DIMENSIONS IN mm

PART NO.	BOLT SIZE	CAPACITY	"A"	"B"	"C"	"D"	"E"	"F"	"G"	"H"
054204-01093	4mm	9KN	4.14	4.69	7.16	15.88	6.54	12.7	0.36	1.27
054206-01203	6mm	20KN	6.16	6.89	10.17	18.12	6.48	12.7	0.36	1.27
054208-01353	8mm	35KN	8.16	9.17	15.54	20.52	9.65	19.0	0.51	1.27
054210-01543	10mm	54KN	10.16	11.22	15.75	23.95	10.67	22.2	0.56	2.03
054212-01084	12mm	80KN	12.16	13.49	20.48	28.22	11.56	25.4	0.66	2.03
054214-01114	14mm	110KN	14.16	15.57	23.09	30.81	12.57	28.6	0.71	2.03
054216-01144	16mm	140KN	16.16	17.75	24.75	34.24	13.31	31.8	0.81	3.18
054218-01184	18mm	180KN	18.16	20.04	31.05	41.14	15.11	38.1	0.94	3.18
054220-01224	20mm	220KN	20.16	22.05	31.05	41.14	15.11	38.1	0.94	3.18
054222-01274	22mm	270KN	22.16	24.30	36.34	47.95	16.89	44.5	1.07	3.18
054224-01324	24mm	320KN	24.16	26.60	43.66	54.86	18.67	50.8	1.19	3.18
054226-01324	26mm	320KN	26.21	28.60	43.660	54.86	18.67	50.8	1.19	3.18
054236-01804	36mm	800KN	36.27	38.81	62.29	79.50	22.22	76.2	1.52	4.57

CABLE / TERMINATION OPTIONS

- 10 FT 4 COND. CABLE - PIGTAIL ENDS
- 15 FT 4 COND. CABLE - PIGTAIL ENDS
- 20 FT 4 COND. CABLE - PIGTAIL ENDS
- DB9 CONNECTOR
WIRING: PIN 1 +EXC.
PIN 3 +SIG.
PIN 4 -SIG.
PIN 6 -EXC.
- DB15 CONNECTOR
WIRING: PIN 1 -SIG.
PIN 2 +SIG.
PIN 9 +EXC.
PIN 10 -EXC.

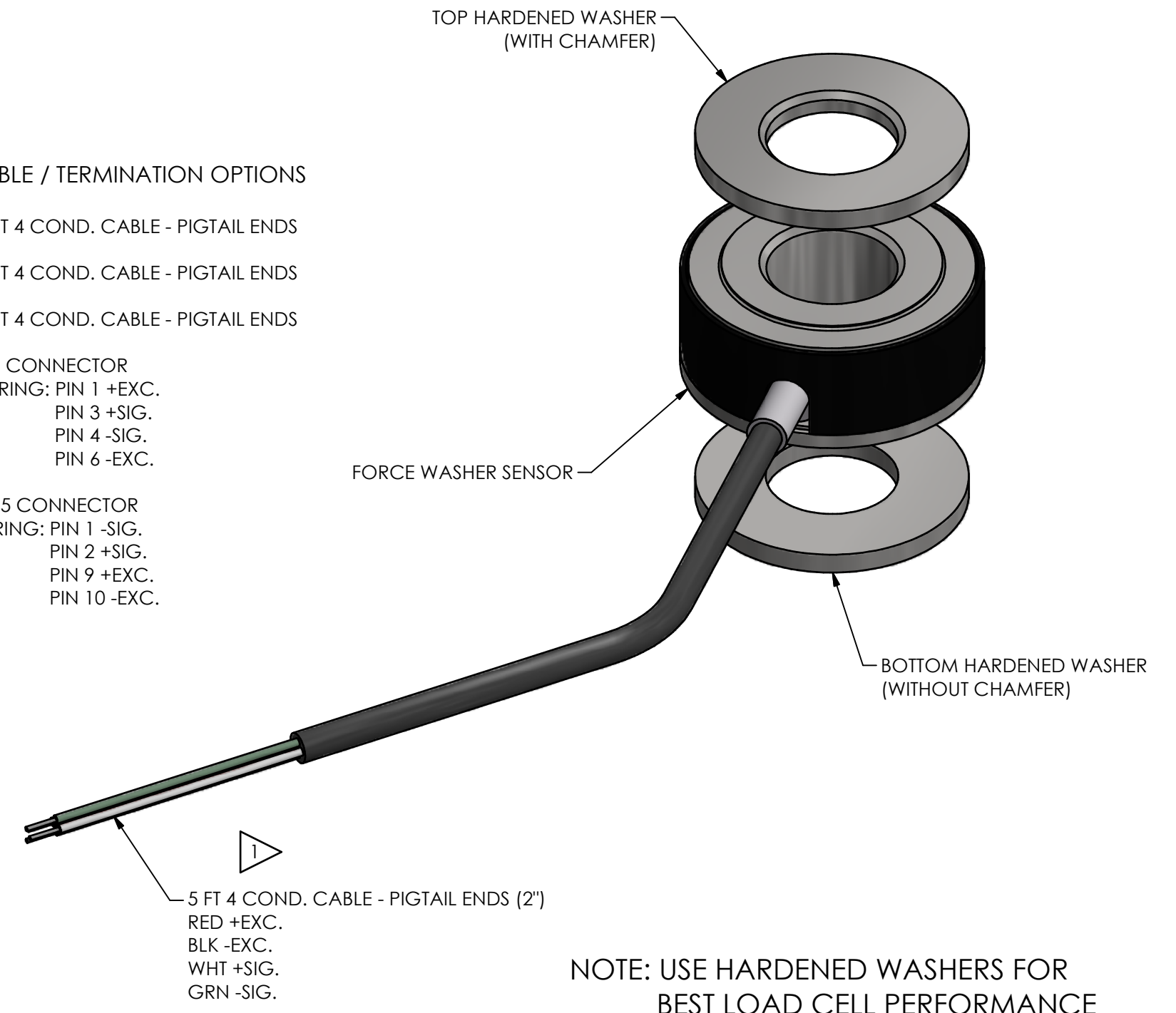

UNLESS OTHERWISE SPECIFIED TOLERANCES ARE:		DRAWN	CHECKED	ENGINEER	 24350 Indoplex Circle, Farmington Hills, MI 48335 (716) 684-0001 E-MAIL: ltinfo@pcbloadtorque.com DWG. NO.		
DIMENSIONS IN INCHES	DIMENSIONS IN MILLIMETERS [IN BRACKETS]	PTE	03.27.15	JSD		03.31.15	PTE
DECIMALS .XX ±0.01 XXX ±0.005	DECIMALS X ±0.3 XX ±0.13	TITLE			OUTLINE DRAWING FORCE WASHER SENSOR ENGLISH AND METRIC VERSIONS		SCALE: NONE SHEET 1 OF 1
ANGLES ± .5 DEGREES	ANGLES ± .5 DEGREES	FILLET AND RADII .015 MAX		FILLET AND RADII 0.38 MAX		LT30776	