

PCB Load & Torque (A Division of PCB Piezotronics, Inc.)
 claims proprietary rights in the information disclosed herein.
 Neither it nor any reproduction thereof will be disclosed to
 others without the written consent of PCB Load and Torque.

49862

REVISIONS		
REV	DESCRIPTION	ECO
A	ADDED TOLERANCE AND SI DIMENSIONS - 01.25.17, PTE	46403

ISO VIEW
 SCALE 1 : 1

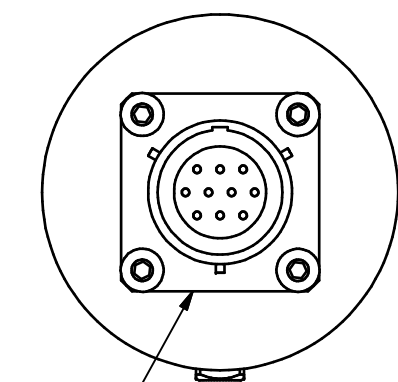
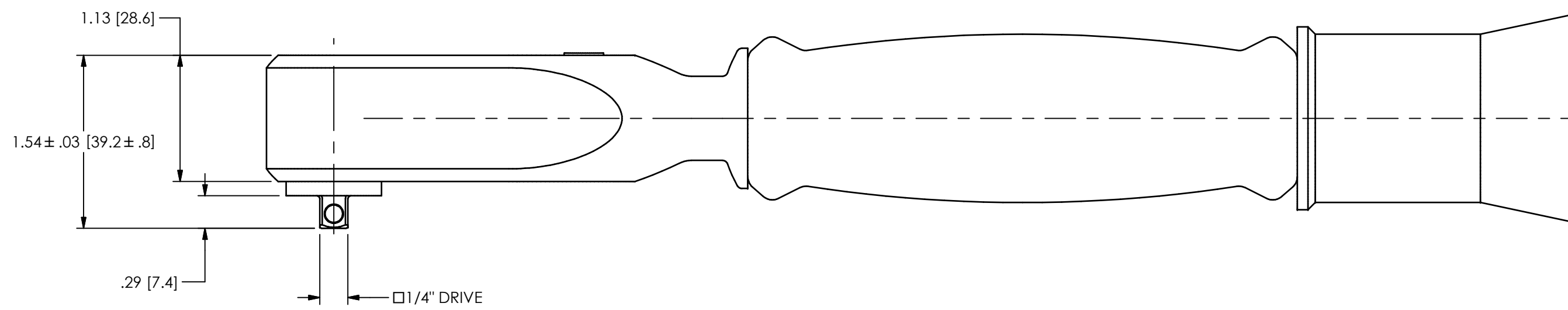
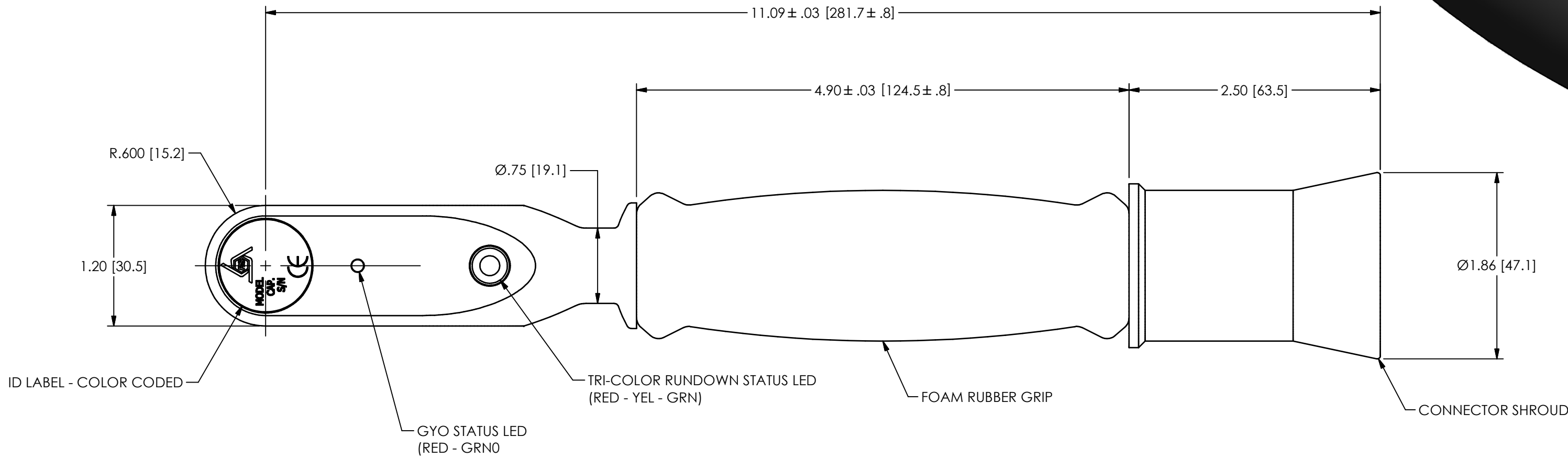
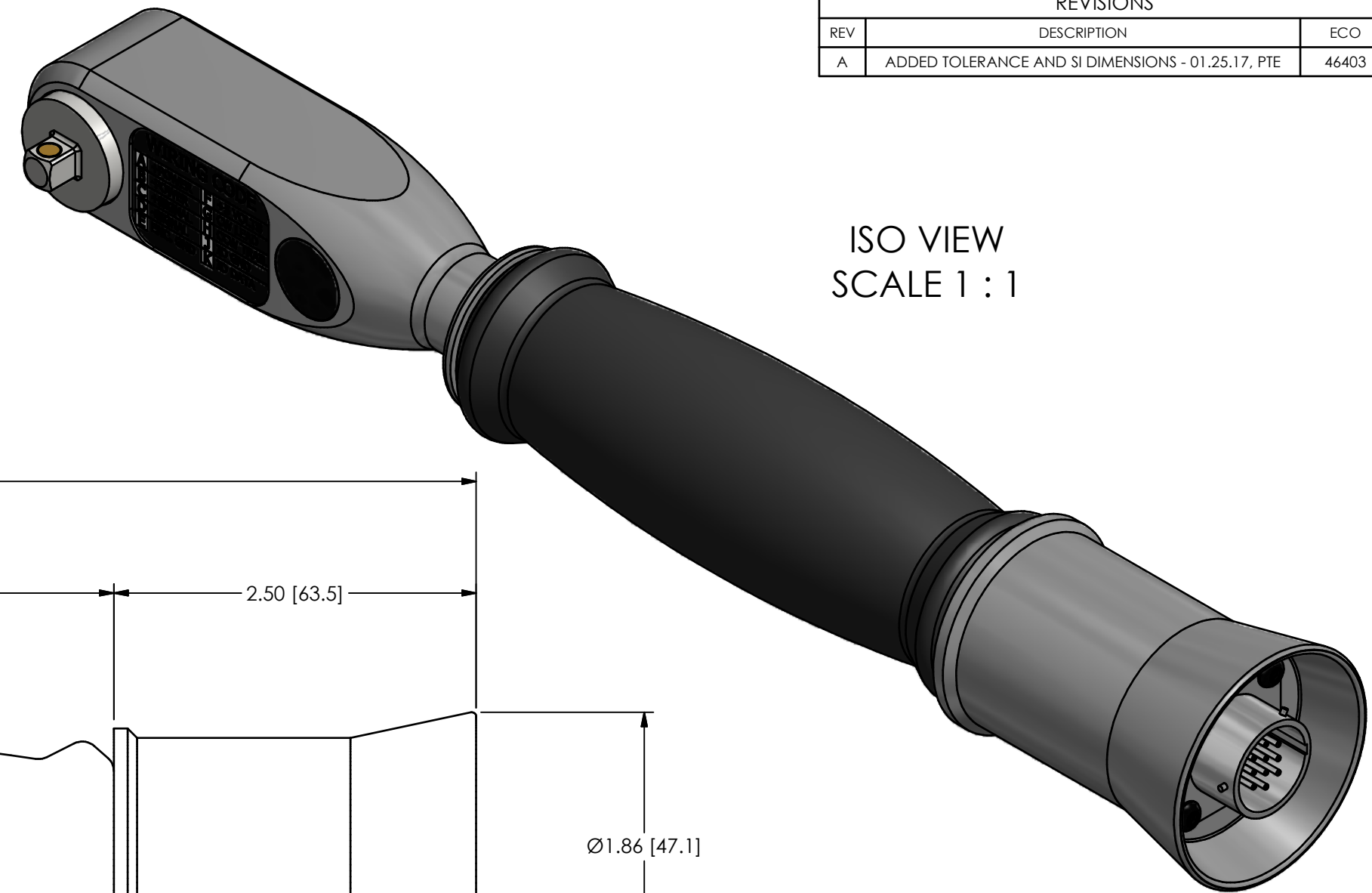

PUSH/TURN RECEPTACLE
 (PT02A-12-10P OR EQUIV.)
 WIRING CODE:
 PIN A +EXC.
 PIN B -EXC.
 PIN C +SIG.
 PIN D- SIG.
 PIN E ENC. GRD
 PIN F +5 VOLTS
 PIN G CW LEAD
 PIN H CCW TRAIL
 PIN J ID GRD
 PIN K ID DATA

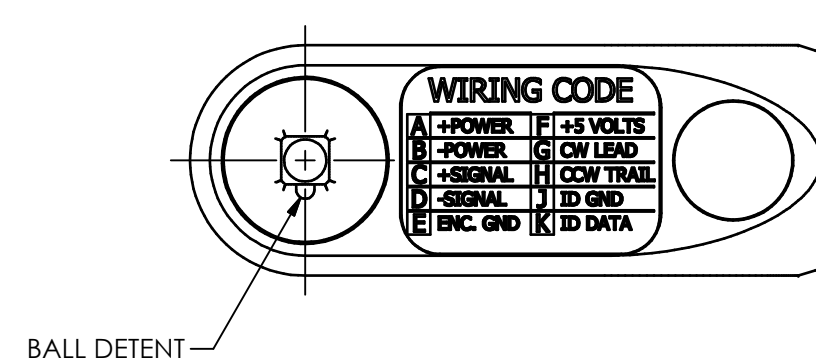

UNLESS OTHERWISE SPECIFIED TOLERANCES ARE:		DRAWN	CHECKED	ENGINEER	 24350 Indoplex Circle, Farmington Hills, MI 48335 (248) 888-8260 E-MAIL: linfo@pcb.com
DIMENSIONS IN INCHES	DIMENSIONS IN MILLIMETERS [IN BRACKETS]	PTE 03.02.16	JSD 04.01.16	PTE 03.02.16	
DECIMALS .XX ±.01 XXX ±.005	DECIMALS X ± 0.3 XX ± 0.13	TITLE			DWG. NO.
ANGLES ± .5 DEGREES	ANGLES ± .5 DEGREES	OUTLINE DRAWING 1/4" SQ DRIVE HAND TORQUE/ANGLE WRENCH			49862
FILLETS AND RADII .015 MAX	FILLETS AND RADII 0.38 MAX	SCALE: FULL			SHEET 1 OF 1