

1206

APPLICATION		
NEXT ASS'Y	USED ON	VAR

REVISIONS				
REV	DESCRIPTION	ECN	DATE	APP'D

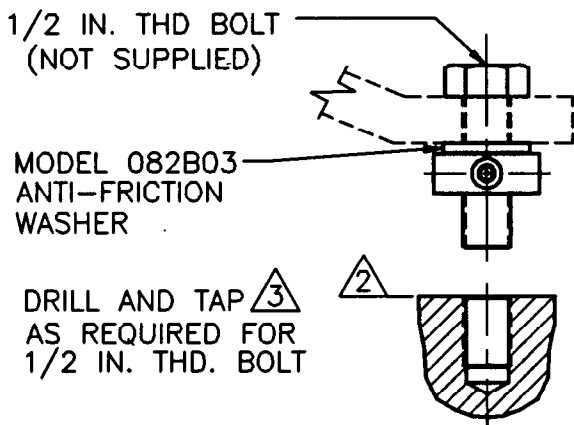
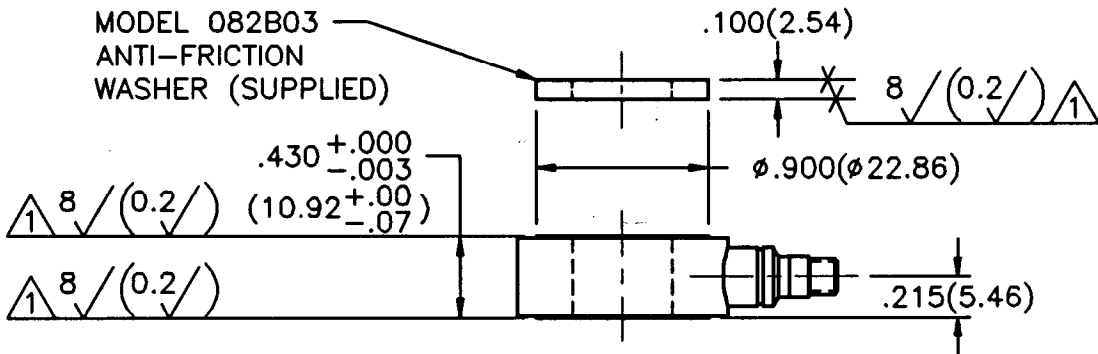
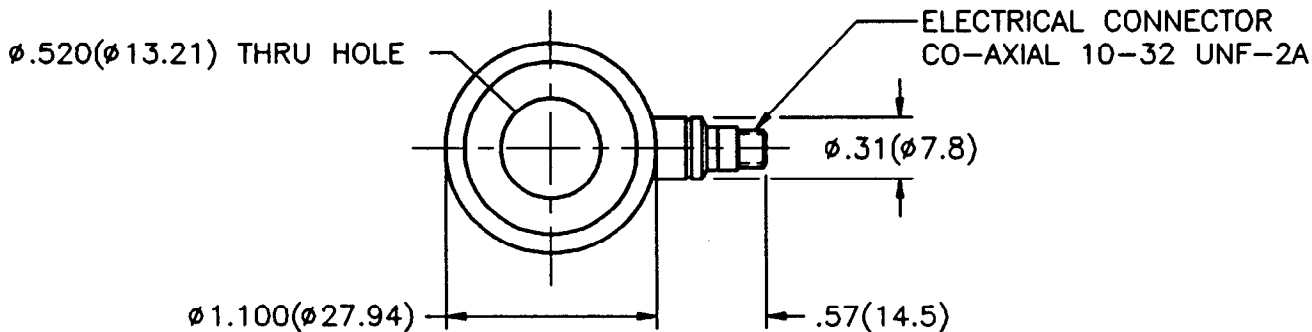

SCALE: .5X

TYP BOLT MOUNTING
INSTALLATION

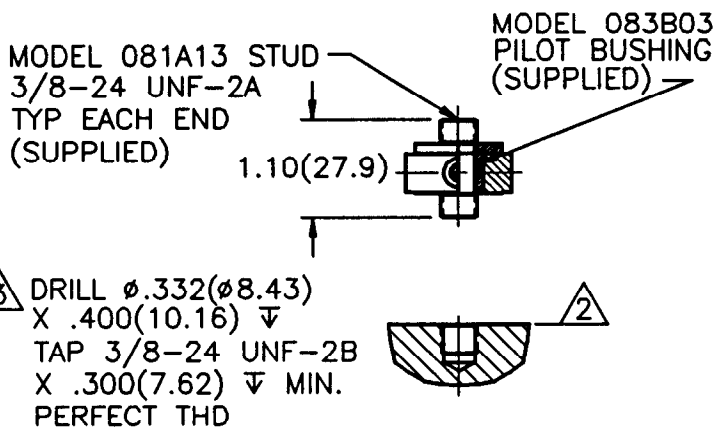

SCALE: .5X

TYP STUD MOUNTING
INSTALLATION

4.) SEE MANUAL FOR PRELOAD INSTRUCTIONS.

- $\Delta 3$ DRILL PERPENDICULAR TO MOUNTING SURFACE WITHIN ± 1 DEGREE.
- $\Delta 2$ MOUNTING SURFACE UNDER FORCE RING MUST BE FLAT TO WITHIN $.001(.03)$ WITH AT LEAST $63 \sqrt{(1.6/\text{)}}$.
- $\Delta 1$ THESE SURFACES FLAT TO WITHIN $.001(.03)$ TIR.

UNLESS SPECIFIED TOLERANCES		DRAWN	CHK'D	APP'D	TITLE	CODE IDENT. NO.	DWG. NO.
DIMENSIONS IN INCHES	DIMENSIONS IN MILLIMETERS (IN PARENTHESIS)	<i>ZAB</i>	<i>DM</i>	<i>HS</i>	INSTALLATION DRAWING MODEL 213B FORCE RING	52681	1206
DECIMALS XX $\pm .01$ XXX $\pm .005$	DECIMALS X ± 0.3 XX ± 0.13	5/16/94	5/16/94	5/16/94			
ANGLES ± 2 DEGREES	ANGLES ± 2 DEGREES	MFG	ENGR	Sales			
FILLETS AND RADII $.003 - .005 (0.07 - 0.13)$							
							SCALE: FULL SHEET 1 OF 1

PCB PIEZOTRONICS, INC.
 3425 WALDEN AVE. DEPEW, NEW YORK 14043
 PHONE: (716) 684-0001