

PCB Piezotronics Inc. claims proprietary rights in the information disclosed hereon. Neither it nor any reproduction thereof will be disclosed to others without the written consent of PCB Piezotronics Inc.

| REVISIONS | | |
|-----------|-----------------------|-------|
| REV | DESCRIPTION | DIN |
| A | UPDATED MAIN ASSEMBLY | 43883 |

10947

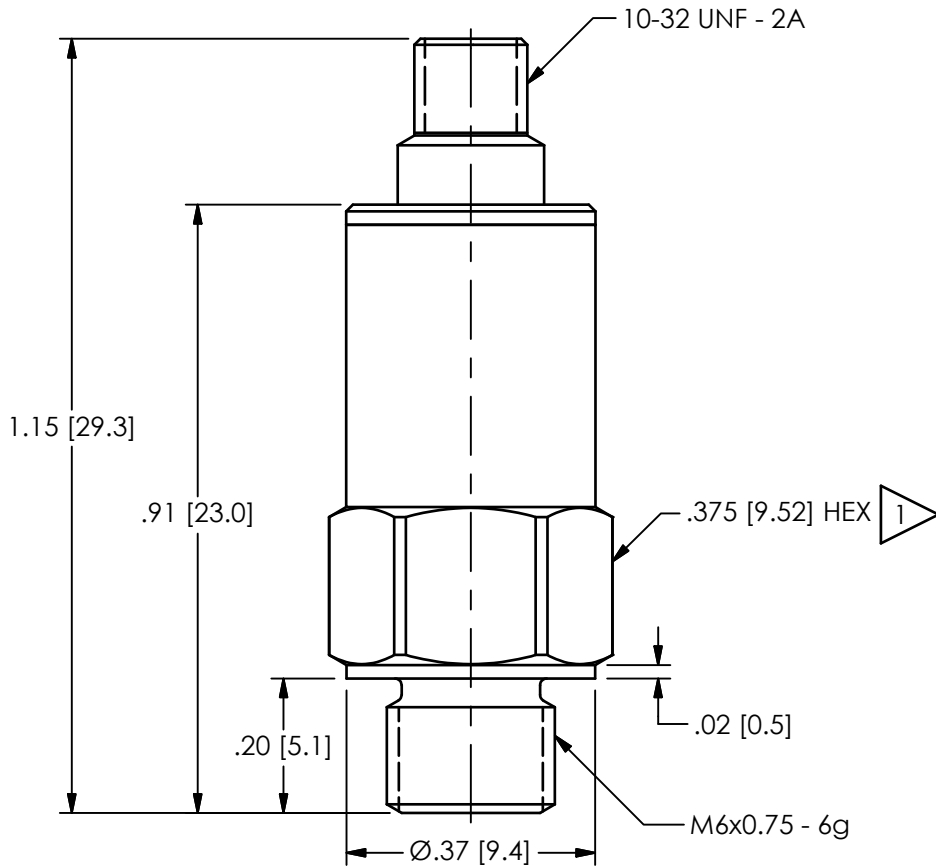

MOUNTING HOLE PREPARATION
 $\text{Ø}209 [\text{Ø}5.31] \nabla .30 [7.6] \text{ MIN.}$
 $\text{M6X0.75-6H} \nabla .20 [5.1] \text{ MIN.}$

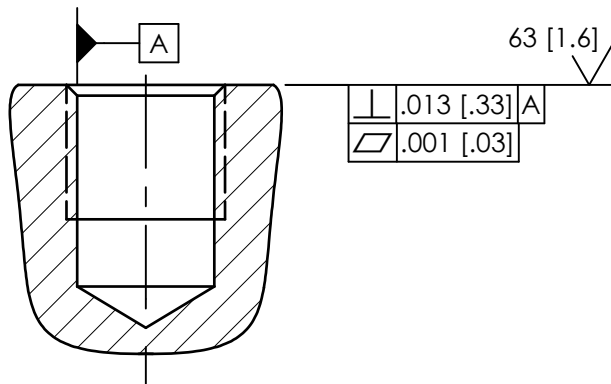

1 RECOMMENDED MOUNTING TORQUE ON .375 [9.52] HEX 2.4-4 FOOT POUNDS (2.8-3.4 NEWTON METERS).

| UNLESS OTHERWISE SPECIFIED TOLERANCES ARE: | | DRAWN | | CHECKED | | ENGINEER | | 3425 WALDEN AVE. DEPEW, NY 14043 (716) 684-0001 E-MAIL: sales@pcb.com | |
|--|---|--|---------|--------------|---------|----------|---------|--|--------------------------|
| DIMENSIONS IN INCHES | DIMENSIONS IN MILLIMETERS [IN BRACKETS] | BB | 4/20/15 | ECB | 4/20/15 | MAM | 4/20/15 | | |
| DECIMALS XX ±.01 XXX ±.005 | DECIMALS X ± 0.3 XX ± 0.13 | TITLE INSTALLATION DRAWING METRIC MECHANICALLY FILTERED SHOCK ACCELEROMETER | | | | | | | CODE IDENT. NO. 52681 |
| ANGLES ± 2 DEGREES | ANGLES ± 2 DEGREES | | | | | | | | DWG. NO. 10947 |
| FILLETS AND RADII .003 - .005 | FILLETS AND RADII 0.07 - 0.13 | SCALE: 3.5X | | SHEET 1 OF 1 | | | | | |