



## Model 112B05

High temperature (+500 F/+260 C) pressure sensor, 5000 psi, 1 pC/psi, 0.218" dia. SS diaphragm, accel. comp., 5-point cal ranges at 5kpsi, 500psi and 100psi

### Installation and Operating Manual

For assistance with the operation of this product,  
contact the PCB Piezotronics, Inc.

Toll-free: 716-684-0001  
24-hour SensorLine: 716-684-0001  
Fax: 716-684-0987  
E-mail: [info@pcb.com](mailto:info@pcb.com)  
Web: [www.pcb.com](http://www.pcb.com)



## Repair and Maintenance

PCB guarantees Total Customer Satisfaction through its “Lifetime Warranty Plus” on all Platinum Stock Products sold by PCB and through its limited warranties on all other PCB Stock, Standard and Special products. Due to the sophisticated nature of our sensors and associated instrumentation, **field servicing and repair is not recommended and, if attempted, will void the factory warranty.**

Beyond routine calibration and battery replacements where applicable, our products require no user maintenance. Clean electrical connectors, housings, and mounting surfaces with solutions and techniques that will not harm the material of construction. Observe caution when using liquids near devices that are not hermetically sealed. Such devices should only be wiped with a dampened cloth—never saturated or submerged.

In the event that equipment becomes damaged or ceases to operate, our Application Engineers are here to support your troubleshooting efforts 24 hours a day, 7 days a week. Call or email with model and serial number as well as a brief description of the problem.

## Calibration

Routine calibration of sensors and associated instrumentation is necessary to maintain measurement accuracy. We recommend calibrating on an annual basis, after exposure to any extreme environmental influence, or prior to any critical test.

PCB Piezotronics is an ISO-9001 certified company whose calibration services are accredited by A2LA to ISO/IEC 17025, with full traceability to SI through N.I.S.T. In addition to our standard calibration services, we also offer specialized tests, including: sensitivity at elevated or cryogenic temperatures, phase response, extended high or low frequency response, extended range, leak testing, hydrostatic pressure testing, and others. For more information, contact your local PCB Piezotronics distributor, sales representative, or factory customer service representative.

## Returning Equipment

If factory repair is required, our representatives will provide you with a Return Material Authorization (RMA) number, which we use to reference any information you have already provided and expedite the repair process. This number should be clearly marked on the outside of all returned package(s) and on any packing list(s) accompanying the shipment.

## Contact Information

PCB Piezotronics, Inc.  
3425 Walden Ave.  
Depew, NY14043 USA  
Toll-free: (800) 828-8840  
24-hour SensorLine: (716) 684-0001  
General inquiries: [info@pcb.com](mailto:info@pcb.com)  
Repair inquiries: [rma@pcb.com](mailto:rma@pcb.com)

For a complete list of distributors, global offices and sales representatives, visit our website, [www.pcb.com](http://www.pcb.com).

## Safety Considerations

This product is intended for use by qualified personnel who recognize shock hazards and are familiar with the precautions required to avoid injury. While our equipment is designed with user safety in mind, the protection provided by the equipment may be impaired if equipment is used in a manner not specified by this manual.

Discontinue use and contact our 24-Hour Sensorline if:

- Assistance is needed to safely operate equipment
- Damage is visible or suspected
- Equipment fails or malfunctions

For complete equipment ratings, refer to the enclosed specification sheet for your product.

## Definition of Terms and Symbols

The following symbols may be used in this manual:



### DANGER

Indicates an immediate hazardous situation, which, if not avoided, may result in death or serious injury.

**CAUTION**

Refers to hazards that could damage the instrument.

**NOTE**

Indicates tips, recommendations and important information. The notes simplify processes and contain additional information on particular operating steps.

**The following symbols may be found on the equipment described in this manual:**



This symbol on the unit indicates that high voltage may be present. Use standard safety precautions to avoid personal contact with this voltage.



This symbol on the unit indicates that the user should refer to the operating instructions located in the manual.



This symbol indicates safety, earth ground.



PCB工业监视和测量设备 - 中国RoHS2公布表

PCB Industrial Monitoring and Measuring Equipment - China RoHS 2 Disclosure Table

部件名称	有害物质					
	铅 (Pb)	汞 (Hg)	镉 (Cd)	六价铬 (Cr(VI))	多溴联苯 (PBB)	多溴二苯醚 (PBDE)
住房	0	0	0	0	0	0
PCB板	X	0	0	0	0	0
电气连接器	0	0	0	0	0	0
压电晶体	X	0	0	0	0	0
环氧	0	0	0	0	0	0
铁氟龙	0	0	0	0	0	0
电子	0	0	0	0	0	0
厚膜基板	0	0	X	0	0	0
电线	0	0	0	0	0	0
电缆	X	0	0	0	0	0
塑料	0	0	0	0	0	0
焊接	X	0	0	0	0	0
铜合金/黄铜	X	0	0	0	0	0
本表格依据 SJ/T 11364 的规定编制。						
0：表示该有害物质在该部件所有均质材料中的含量均在 GB/T 26572 规定的限量要求以下。						
X：表示该有害物质至少在该部件的某一均质材料中的含量超出 GB/T 26572 规定的限量要求。						
铅是欧洲RoHS指令2011/65/ EU附件三和附件四目前由于允许的豁免。						

CHINA RoHS COMPLIANCE

Component Name	Hazardous Substances					
	Lead (Pb)	Mercury (Hg)	Cadmium (Cd)	Chromium VI Compounds (Cr(VI))	Polybrominated Biphenyls (PBB)	Polybrominated Diphenyl Ethers (PBDE)
Housing	O	O	O	O	O	O
PCB Board	X	O	O	O	O	O
Electrical Connectors	O	O	O	O	O	O
Piezoelectric Crystals	X	O	O	O	O	O
Epoxy	O	O	O	O	O	O
Teflon	O	O	O	O	O	O
Electronics	O	O	O	O	O	O
Thick Film Substrate	O	O	X	O	O	O
Wires	O	O	O	O	O	O
Cables	X	O	O	O	O	O
Plastic	O	O	O	O	O	O
Solder	X	O	O	O	O	O
Copper Alloy/Brass	X	O	O	O	O	O

This table is prepared in accordance with the provisions of SJ/T 11364.

O: Indicates that said hazardous substance contained in all of the homogeneous materials for this part is below the limit requirement of GB/T 26572.

X: Indicates that said hazardous substance contained in at least one of the homogeneous materials for this part is above the limit requirement of GB/T 26572.

Lead is present due to allowed exemption in Annex III or Annex IV of the European RoHS Directive 2011/65/EU.

## 1.0 INTRODUCTION

Quartz charge mode pressure sensors offer high performance for precise pressure measurements over a wide range of near-static and dynamic pressures. The sensors use the piezoelectric properties of quartz to convert an applied pressure into an analogous electrical charge.

The internal design of a sensor incorporates a quartz sensing element that provides high sensitivity over a wide range of pressures. As pressure is applied to the diaphragm of the sensor, a charge is generated in the quartz crystals. The high-impedance electrostatic charge is then conditioned externally by either a laboratory-style charge amplifier or in-line charge converter prior to being sent to a readout or recording device.

Charge mode sensors are ideally suited for applications where wide dynamic range, high frequency response, and/or high shock phenomena are a consideration. Such applications include compressors, engines, blast, ballistic, pneumatic, hydraulic, and fluid pressures. Enclosed is a Specification Sheet that lists the complete performance characteristics of the sensor purchased.

In addition to the standard features offered with the sensor, a variety of options are also available on **some** sensor models. When listed before the model number, the following prefix letters indicate that the sensor is supplied with optional features:

A option	Ablative thermal barrier
E option	Emralon coating
H option	Hermetic seal
J option	Electrical isolation (mounting adaptor required)
M option	Metric thread
P option	Positive polarity output (for use with non-inverting amplifiers)
V option	Special attached cable (length/type)
W option	Waterproof cable connection

Other prefix letters, such as K, KR, GK, GKR, KL and GKL indicate that the sensor is ordered in kit form, which includes cabling, power supplies and accessory mounting hardware. See the enclosed Prefix Sheet for additional details.

## 2.0 DESCRIPTION

### 2.1 Series 111A General Purpose Miniature Sensor

The Series 111A General Purpose Miniature Sensor is a high-precision, charge mode pressure sensor used for dynamic measurement of compression, combustion, explosion, pulsation, cavitation, blast, pneumatic, hydraulic, fluid and other similar types of dynamic pressure. The series consists of the Models 111A, 111A02, and 111A03 (along with special versions), having pressure ranges of 3 000, 100, and 10 000 psi (20684, 689, and 68947 kPa), respectively. See Figure 2.1.

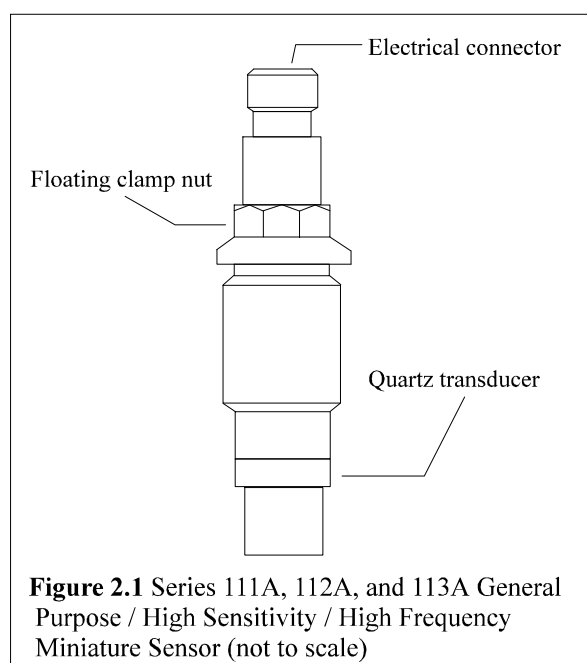

**Figure 2.1** Series 111A, 112A, and 113A General Purpose / High Sensitivity / High Frequency Miniature Sensor (not to scale)

This rugged instrument measures transient or repetitive phenomena, relative to the initial or average level, over a wide amplitude and frequency range. It comfortably tolerates adverse environmental conditions. The sensor follows transient events up to a few percent of the system time constant, which, depending on the system, may be sufficient for static calibration by conventional methods. The sensor's internal design consists of a rigid, multi-plate, compression mode quartz element.

## 2.2 Series 112A High Sensitivity Miniature Sensor

The Series 112A High Sensitivity Miniature Sensor is a high-precision charge mode pressure sensor designed for higher charge sensitivities necessary when measuring compression, combustion, explosion, pulsation, actuation, cavitation, fluid, blast, turbulence and sound pressures. The series consists of the Models 112A, 112A02, and 112A03 (along with special versions), with pressure ranges of 3 000, 100, and 10 000 psi (20684, 689, and 68947 kPa), respectively. See Figure 2.1.

This quartz sensor measures near-static and dynamic pressures from full vacuum to 3 000 psi (15 000 psi optional). It measures transient or repetitive phenomena, relative to the initial or average pressure level, over wide amplitude and frequency ranges and under the most adverse environmental conditions. System voltage sensitivities range from 0.01 mV/psi to 1.0 volt/psi, depending on the charge amplifier involved.

The Series 112A High Sensitivity Sensor contains a rigid multi-plate sensing element with an integral compensating accelerometer to minimize vibration sensitivity. It is housed in all-welded stainless steel.

## 2.3 Models 112A04 and 112A05 High Temperature Miniature Sensor

The Model 112A04/112A05 High Temperature Miniature Sensor is a high-precision, charge mode pressure sensor designed specifically for use in compressors, engines, turbines, heat exchanger combustion chambers and bombs, at moderate and high temperatures. The Models 112A04 and 112A05 operate to a maximum temperature of 600°F ( 315°C). See Figure 2.1.

The all-welded, hermetic stainless steel construction of this sensor ensures reliable operation in high-temperature environments. It is constructed with a rigid, multi-plate sensing element and integral compensating accelerometer to minimize vibration sensitivity.

## 2.4 Series 113A High Frequency Miniature Sensor

The Series 113A High Frequency Miniature Sensor is a charge mode pressure sensor designed to measure shock wave, blast, explosion, ultrasonic and dynamic combustion pressures requiring ultra-fast response times. The Series 113A consists of the Models 113A, 113A02, and 113A03, having pressure ranges of 3 000, 100, and 15 000 psi (20684, 689, and 103420 kPa), respectively. All are acceleration compensated. See Figure 2.1.

This sensor measures transient or repetitive phenomena relative to the initial or average pressure level, over wide amplitude and frequency ranges and under the most adverse environmental conditions.

This stainless steel instrument contains an extremely rigid compression-mode quartz element with an integral compensating accelerometer to reduce vibration sensitivity and partially suppress internal resonance effects. This results in an accurate, dynamic high-frequency response from the sensor.

## 2.5 Series 116 High Sensitivity Sensor

The Series 116 High Sensitivity Sensor is a special-purpose high temperature charge mode pressure sensor designed specifically to measure low-level pressures in severe environments. The unit is most frequently used in engines, hydraulic and pneumatic devices, compressors and turbines. Ideal for sound pressure measurements, microphones and small pressure agitations, its maximum dynamic pressure range is 100 psi (689 kPa). It is acceleration compensated to minimize vibration sensitivity and is capable of a five-microsecond rise time. See Figure 2.2.

This sensor measures transient or repetitive phenomena relative to the initial or average pressure level, over a wide amplitude range and a usable frequency range near DC to between 20 000 and 30 000 Hz; the resonant frequency is 60 000 Hz, except for the Model 116A, which has a resonant frequency of 130 kHz. The Model 116 is extremely sensitive, with a nominal pressure response of 10 pC/psi. The operating temperature for the Series 116A ranges from -400°F to 400°F (-240°C to 204°C). The operating temperature for the Series 116B and 116C ranges from -400°F to 650°F (-240°C to 343°C).

This hermetically sealed stainless steel sensor contains extremely rigid compression-mode quartz crystals with an integral acceleration compensating crystal to reduce vibration sensitivity and partially suppress internal resonance effects.

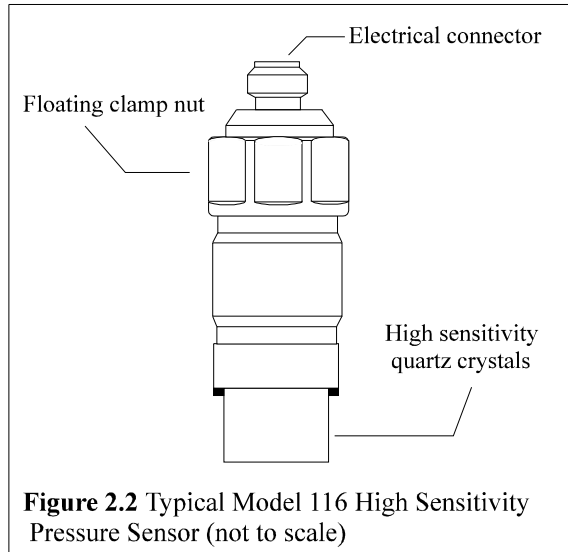
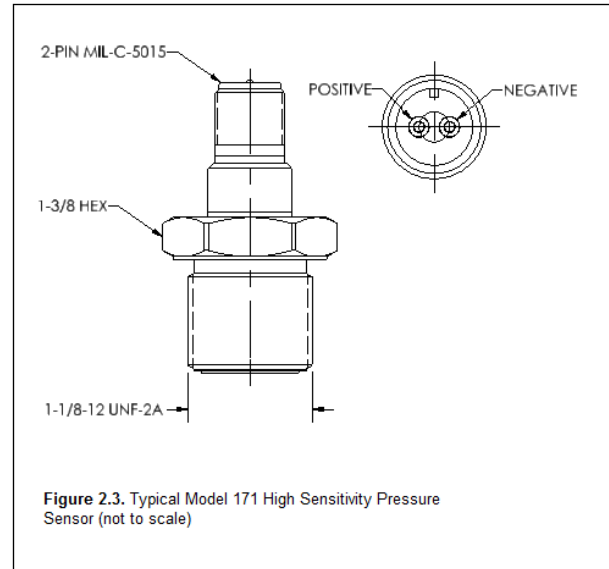

**Figure 2.2** Typical Model 116 High Sensitivity Pressure Sensor (not to scale)

## 2.6 Series 171 High Sensitivity Sensor

The Series 171 High Sensitivity Sensor is a special-purpose high temperature charge mode pressure sensor designed specifically to measure low-level pressures in severe environments. The unit is most frequently used in acoustic devices, compressors and turbines. Ideal for sound pressure measurements, microphones and small pressure agitations, its maximum dynamic pressure range is 600 psi (4136 kPa). See Figure 2.3.

This sensor measures transient or repetitive phenomena relative to the initial or average pressure level, over a wide amplitude range and a usable frequency range near DC to between 5 000 and 10 000 Hz; the resonant frequency is 25 000 Hz. The Model 171 is extremely sensitive, with a nominal pressure response of 1100 pC/psi. The operating temperature for the Series 171 ranges from 0°F to 500°F (-18°C to 260°C).



**Figure 2.3.** Typical Model 171 High Sensitivity Pressure Sensor (not to scale)

## 3.0 INSTALLATION

### 3.1 Overview

When choosing an installation method, the advantages and disadvantages of each method must be carefully weighed. Characteristics like location, ruggedness, amplitude range, accessibility, temperature and portability may be greatly affected by the installation configuration and technique. Often, the most important and overlooked consideration is the affect the mounting technique has on the frequency of the pressure being measured by the sensor.

Two basic mounting techniques are recommended for pressure sensors: the recess mount and the flush mount. The technique used is determined by the specifics of the individual application. See the Installation Drawing in this manual for additional details on the individual sensor series.



Passage length (inches)	Passage resonance (kHz)	Approx. fastest pulse rise time (microseconds)
.050	66	5
.100	33	10
.200	16.5	20
.50	6.6	50
1.0	3.3	100

**3.2 Recess Mount**

A recess mount protects the sensor diaphragm from the effect of high flash temperature and particle impingement. This method is often selected because it can prolong sensor life and increase data integrity by reducing thermal effects. See Figure 3.1.

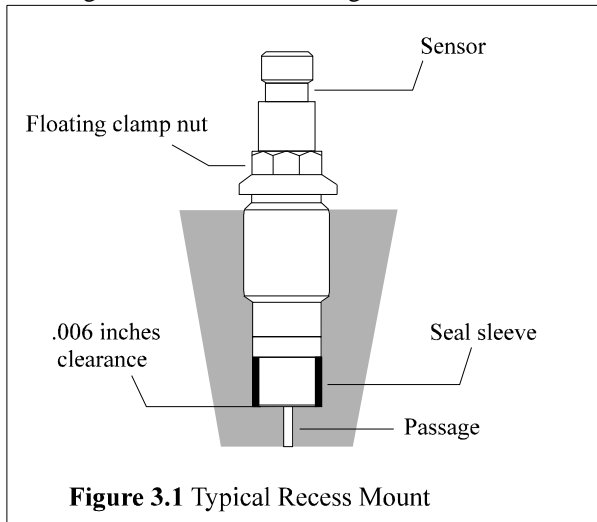

**Figure 3.1** Typical Recess Mount

When using a recess mount, note that the length of the passage may limit the frequency range of the measurement. The effect the passage has is similar to that of an under-damped second order system, with the resonant frequency determined by passage length. The passage length thus limits pressure pulse rise time and may also cause passage ringing.

The function is described by the following equation:

$$F_r = \frac{V}{4L}$$

Where: Fr = resonant frequency passage (Hz)  
 V = velocity of sound in air (feet/second)  
 L = length of column (feet)

For air at room temperature, the equation becomes:

$$F_r = \frac{3300}{L}$$

Where: L = passage length (inches)

The natural frequency and approximately fastest pressure step rise time for various length passages are shown in the following chart, using a medium of air at 77°F (25°C).

**Selected Values for 77°F (25°C)**

Measured resonant frequencies may differ slightly from the chart values due to variations in the velocity of sound in the air from changes in temperature and pressure of the air in the passage.

To ensure diaphragm integrity, maintain .006 inches (.153 mm) of clearance ahead of the diaphragm using seal sleeve Model 065A05, shown in Figure 3.1.

**3.3 Flush Mount**

In a flush mount installation, there is no reduced area passage from the sensor diaphragm to the test chamber. Instead, the sensor diaphragm is mounted flush with, or slightly recessed from, the inside surface of the test chamber. See Figure 3.2.

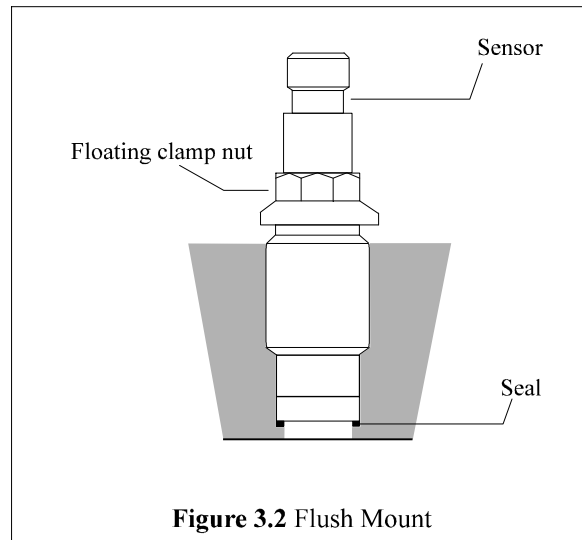

**Figure 3.2** Flush Mount

If thermal transients or diaphragm impingement are concerns, use the flush mount technique only when space or frequency response considerations preclude the use of the recess mount installation.

In severe or pyrotechnic environments, sensor life may be seriously curtailed when using this mounting method.

### 3.4 Flash Thermal Protection

Several additional steps may be taken to provide protection from flash thermal effects. The sensor diaphragm may be thermally insulated at the factory, using a thin (.010 inches / 0.254 mm) coating of ablative silicone rubber, G.E. type 580 ("A" option). Before the insulation is applied, the surface of the diaphragm is treated with SS4004 primer.

If more protection is required, the recess mount may be filled with DC-4 silicone grease or its equivalent. In place of the silicone rubber, one or more layers of black vinyl electrical tape on the diaphragm may provide sufficient insulation.

### 3.5 Miscellaneous Installation Notes

Thread adaptors, such as the Series #61, 3/8-24 or Series #62, 1/8 NPT, provide quick installation where mounting port diameter is not limited. Other adaptors include Series #63 Needle Probe, and Series #64 Water-Cooled. Adaptor use simplifies mounting procedures and improves troubleshooting by reducing the incorrect data that can result from improper mounting. See the PCB General Catalog for details.

A floating clamp nut, Model 060A03 (Model 060A05 for metric), 1/4 hex, facilitates mounting and removal of the sensor by clamping the sensor in place without placing undue stress on the quartz element. The clamp nut is provided with either standard (5/16-24) or metric (M7 x 0.75) threads and is supplied along with three seal rings.

Model 008A Hardline Cable is recommended for operating temperatures above 500°F. This cable is supplied in lengths up to 40 feet (12,19 m).

### 3.6 Cabling

Care and attention to cable attachment is essential, as the reliability and accuracy of your system is no better than that of the output cable. First, check that you have ordered the correct cable type. As with sensors, no cable can satisfy all applications. Special low-noise cabling should be used (e.g., PCB Series 003) with high-impedance, charge output devices.

Connect the cable to the pressure sensor. A small amount of thread locking compound placed on the connector prior to attachment helps secure the cable during testing. For additional protection in harsh environments, the connection may be sealed with protective materials, such as silicon rubber, O-rings and flexible heat-shrink tubing (optional).

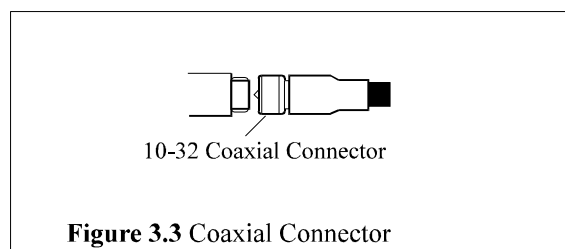

Figure 3.3 Coaxial Connector

Plug the male connector on the cable into the mating female connector on the sensor. Then, holding the sensor stationary, secure the connector in place by tightening down the attached cable sleeve. See Figure 3.3.

Route the cable to a charge amplifier or in-line charge converter, making certain to strain relieve the sensor/cable connection and minimize motion by clamping the cable at regular intervals. Common sense must be used to avoid physical damage and minimize electrical noise. Avoid routing cables near high voltage wires. Do not route cables along floors or walkways where they may be stepped on or become contaminated. Shielded cable should have the shield grounded at one end only.

To dissipate any charge that may have accumulated in the cable, short the signal to ground prior to attachment to the charge amplifier or charge converter.

## 4.0 CALIBRATION

These sensors may be calibrated using static hydraulic techniques, such as dead-weight testers, or by comparison with a reference gage.

When calibrating with a laboratory-style charge amplifier, set the charge amplifier to LONG, for the time constant setting, and allow the sensor to stabilize before applying pressure. If slow drift is apparent, apply the pressure to the desired level, and immediately take a reading. Release the pressure and take another reading at zero pressure to obtain the difference between the readings at the desired present level and zero pressure. If the drift is too fast to take a reading, clean the cable connections according to the procedures out-lined in Section 7.0, Maintenance.

**NOTE:** Do not attempt to use a charge amplifier which, in the long time constant position, has less than a 5 000-second time constant for quasi-static calibration of charge sensors. Any drift may cause error.

Several charge amplifiers are designed especially for use with ceramic sensors, for higher low-frequency measurements. In general, these types are unsuitable for calibration of quartz pressure sensors by quasi-static means.

A factory-supplied, NIST-traceable calibration graph is provided with each sensor, certifying its charge sensitivity in pC/psi, or when used with an in-line voltage amplifier, in mV/psi.

## 5.0 NORMAL OPERATION

The high impedance signal generated by a charge output sensor is usually conditioned with a laboratory-style charge amplifier, such as the PCB Model 462A. The charge amplifier converts the high-impedance charge signal generated by the sensor into a low-impedance voltage signal. This signal may then be transmitted to a readout or recording device for analysis. See Figure 5.1 for a drawing of a typical system connection.

**NOTE:** When using charge-amplified systems, the noise floor of the system is dependent on the input capacitance to the charge amplifier. To minimize noise, keep the cable length between the pressure sensor and the charge amplifier to a minimum. Cable length does not affect the system sensitivity.

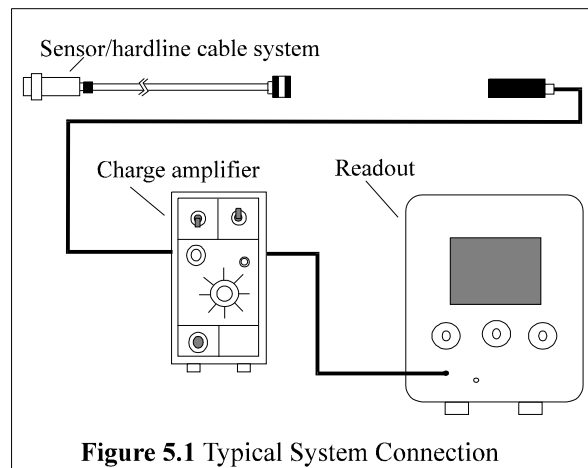

Figure 5.1 Typical System Connection

Before connecting the low-noise cable from the pressure sensor to the charge amplifier, be certain to ground the charge amplifier. This ensures that any excessive accumulated static charges across the sensor/cable combination are harmlessly discharged. If this precaution is not observed, the input FET of certain amplifiers may be destroyed. Press the ground button of the charge amplifier and adjust electrical zero if necessary.

Once system components are connected, wait a few minutes for the system to thermally stabilize. Place the switch in the OPR (operate) position and proceed with the measurement. Refer to the charge amplifier operating manual for further operating details.

For fixed sensitivity in-line charge amplifiers, such as the PCB Series 422, the system sensitivity (mV/psi) is determined as the product of the charge amplifier sensitivity (mV/pC) and the sensor sensitivity (pC/psi). With in-line voltage amplifiers, the system sensitivity is a function of the sensor, cable, and the in-line voltage amplifier.

### 5.1 Polarity

When subjected to increasing pressure, these pressure sensors have a standard negative-going charge output. Because most charge amplifiers are signal-inverting, the resultant signal is positive-going. Reverse-polarity sensors, for use with non-inverting source follower amplifiers, are available upon request ("P" option).

## 6.0 HIGH-TEMPERATURE OPERATION

### 6.1 Introduction

When subjected to elevated temperature, all piezoelectric sensors/hardline cable systems exhibit decreased insulation resistance, due in part to the piezoelectric element, but due mostly to the hardline cable necessary to withstand the high temperatures. This situation can cause serious voltage offset problems in direct-coupled charge amplifiers, such as PCB Models 462, 463, and 464, as well as with the miniature Series 422. To solve this problem, the user must AC couple (capacitor) the charge amplifier to the sensor/cable system. See Section 6.3, Solution to Reduced Resistance, for complete details.

### 6.2 Reduced Resistance at Charge Amplifier Input

Figure 6.1 illustrates a simplified schematic of a typical direct-coupled charge amplifier where:

- $R_f$  = Feedback resistor (ohms)
- $R_i$  = Input leakage resistance (ohms)
- $E_o$  = Steady-state output voltage (volts)
- $e_i$  = Offset voltage: FET leakage (volts)
- $C_f$  = Feedback capacitor (farads)

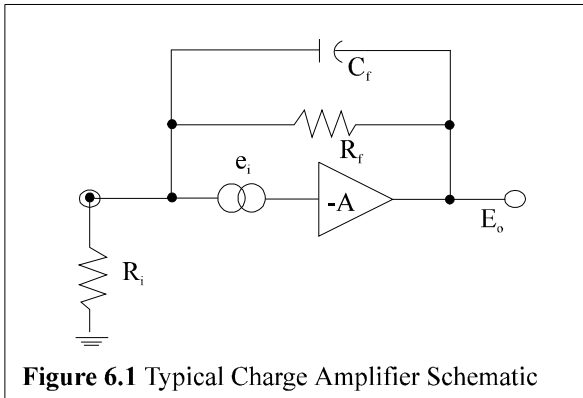

Figure 6.1 Typical Charge Amplifier Schematic

The feedback capacitor  $C_f$  comes into play only in the dynamic situation and its influence does not affect the steady-state situation. The voltage  $e_i$  is a DC offset voltage, usually very tiny (microvolts), that exists at the input gate of the MOSFET circuit. This minute leakage current exists in all real devices. As demonstrated in Equation 1, the steady-state (DC) output voltage  $E_o$  is:

Equation 1

$$E_o = e_i \left( 1 + \frac{R_f}{R_i} \right)$$

This equation shows that if the input (leakage) resistance at the charge amplifier is extremely high (approaching infinity), the output DC voltage approaches  $e_i$ , usually a very tiny voltage. However, as  $R_i$  decreases, the term

$$1 + \frac{R_f}{R_i}$$

increases, such that the output voltage can, with large ratios of  $R_f/R_i$ , become large enough to result in a large  $E_o$ , perhaps large enough to be outside the normal output voltage range of the charge amplifier.

Because of the feedback capacitor  $C_f$ , this output voltage change usually does not occur rapidly but rather, it manifests itself as a slow drift in the output voltage level. If  $R_i$  is low enough with respect to  $R_f$ , the voltage drift may continue until saturation of the charge amplifier occurs.

### 6.3 Solution to Reduced Resistance

Since the drift or offset problem is caused by a static or steady-state imbalance at the input of the charge amplifier, the solution involves blocking this steady-state effect while allowing the desired dynamic phenomena to pass. This may be accomplished by installing a series capacitor at the input of the charge amplifier, between the offending sensor (or low-impedance hardline) and the input.

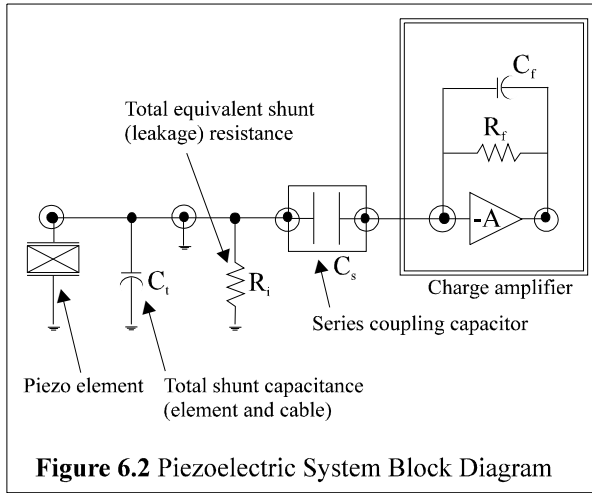

Figure 6.2 illustrates a block diagram of the piezo-electric system where:

- $C_t$  = Shunt capacitor
- $C_s$  = Series blocking capacitor

With the series blocking capacitor  $C_s$  in place as shown, the dynamic charge ( $Q$ ) generated by the sensor element is distributed across the two capacitors,  $C_t$  and  $C_s$ , in proportion to the size (capacitance) of each. If  $C_s$ , for example, is equal to 100 times  $C_t$ , 99% of the charge appears at the input of the charge amplifier, while 1% is across the shunt capacitor  $C_t$ . This results in a 1% decrease in apparent sensitivity of the system.

This therefore demonstrates the importance of selecting the series blocking capacitor at least two orders of magnitude higher than the total shunt capacitance  $C_t$  across the input of the charge amplifier.

It is also important that this capacitor be of high quality, with a leakage resistance of greater than  $10^{12}$  ohms, to avoid the DC offset discussed previously in 6.1, Introduction.

### 6.4 Low-Frequency Response Limitations

In a normal charge amplifier, the low-frequency response is set by the RC time constant, as established by the product of  $C_f$  and  $R_f$ . The system acts like a high-pass first order RC filter with a -3 dB frequency established by the relationship:

Equation 2

$$f_o = \frac{.16}{R_f C_f}$$

where:

- $f_o$  = -3 dB Frequency (Hz)
- $R_f$  = Feedback resistor (ohms)
- $C_f$  = Feedback capacitor (farads)

However, after the addition of the series blocking capacitor  $C_s$ , the system becomes the equivalent of two high-pass filters in series, one as previously mentioned and one comprised of series capacitor  $C_s$  and total equivalent shunt resistance  $R_l$ . This new cutoff frequency is:

Equation 3

$$f_o = \frac{.16}{R_l C_s}$$

To avoid compromise of the low-frequency response established by the charge amplifier parameters and illustrated by Equation 2, the product of  $R_l C_s$  should be several orders of magnitude higher than  $R_f C_f$ .

The approximate final system discharge time constant becomes:

Equation 4a

$$TC = \frac{1}{\frac{1}{R_l C_s} + \frac{1}{R_f C_f}} \quad \text{seconds}$$

If the input coupling time constant ( $R_l C_s$ ) is very much greater than the discharge time constant of the charge amplifier ( $R_f C_f$ ), Equation 4a then becomes:

Equation 4b

$$\frac{1}{R_l C_s} \Rightarrow 0 \text{ Seconds}$$

Equation 5

$$TC = R_f C_f$$

With the product  $R_f C_s$  chosen to be  $>$  than  $R_f C_f$ , the system discharge time constant is simply  $R_f C_f$  (seconds). The feedback parameters of the charge amplifier establish the low frequency characteristics of the system, unaffected by the degraded input resistance parameters of the test sensor and/or cable.

The solution to most low-frequency response limitations lies in the selection of a high-quality coupling capacitor of sufficient size (capacitance) to allow a drastic reduction in insulation resistance of the sensor/cable, with little or no performance degradation. The PCB Model 072A coupling capacitor can solve many such problems; while optional, it is recommended for use with many high-temperature systems. It consists of a 10 000 pF high-quality polystyrene capacitor in a housing convenient for threading directly onto most hardline cable assemblies. See Figures 5.1 (system placement) and 6.3 (coupling capacitor drawing). The Model 072A is configured with a 10-32 micro-connector at each end, one end with the female jack and the other end with a male plug.

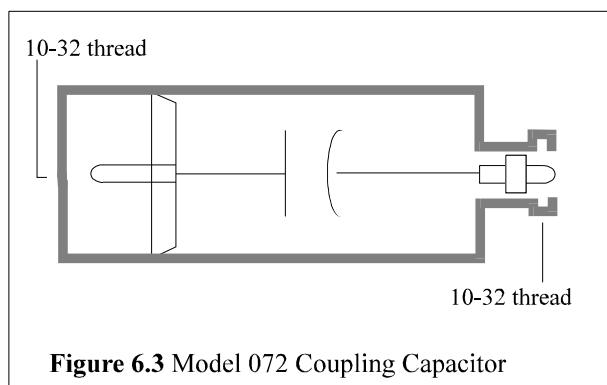

**Figure 6.3** Model 072 Coupling Capacitor

## 6.5 Other Precautions

Always remember to keep the OPR-GND switch on the charge amplifier in the GND position while connecting or disconnecting sensors, cable, or capacitor to the input connector. Stray or accumulated electrostatic charges may build to the point that they may saturate or even damage the input circuitry of the charge amplifier.

Operate the charge amplifier in the SHORT time constant while the sensor is subject to elevated or changing temperatures. If it is not necessary to procure data during the transition from room temperature to operating temperature, place the OPR-GND switch in

the GND position to keep spurious, thermally generated charges grounded.

It is prudent to momentarily switch to the GND position even during the measurement period to ensure that excess charges do not accumulate at the input of the charge amplifier.

## 7.0 MAINTENANCE

The only maintenance required on the pressure sensor is to keep the connector clean. If it is operating in a dirty environment, protect the cable connections with heat-shrink tubing or similar material.

In the event that the electrical connection of the pressure sensor becomes contaminated with dirt or moisture, the insulation resistance degrades. This may cause a reduction of sensitivity or excessive drifting when connected to the charge amplifier. If this happens, brush off the connector with no-residue solvent or other approved cleaning solutions. To restore insulation, bake the sensor in a vacuum oven at 250°F for about four hours. If the condition persists even after cleaning and/or baking, please contact a PCB applications engineer for further assistance. The sensor is hermetically sealed; it must therefore be returned to the factory if the aforementioned measures fail to restore performance.

Model Number  
112B05

# CHARGE OUTPUT PRESSURE SENSOR

Revision: C  
ECN #: 54975

	ENGLISH	SI	
<b>Performance</b>			
Sensitivity(± 15 %)	1.1 pC/psi	.16 pC/kPa	
Measurement Range	5,000 psi	34,475 kPa	
Maximum Pressure(Total)	10,000 psi	68,950 kPa	
Resonant Frequency	≥ 200 kHz	≥ 200 kHz	
Rise Time(Reflected)	≤ 2.0 μ sec	≤ 2.0 μ sec	
Non-Linearity	≤ 1.0 % FS	≤ 1.0 % FS	[1]
<b>Environmental</b>			
Acceleration Sensitivity	0.003 psi/g	0.0021 kPa/(m/s <sup>2</sup> )	[2]
Temperature Range(Operating)	-400 to +500 °F	-240 to +260 °C	
Temperature Response	See Graph	See Graph	[2]
Maximum Flash Temperature	3,000 °F	1,649 °C	
Maximum Vibration	5,000 g pk	49,000 m/s <sup>2</sup> pk	
Maximum Shock	10,000 g pk	98,000 m/s <sup>2</sup> pk	
<b>Electrical</b>			
Output Polarity(Positive Pressure)	Negative	Negative	
Capacitance	24 pF	24 pF	[2]
Insulation Resistance(at room temp)	≥ 10 <sup>12</sup> Ohm	≥ 10 <sup>12</sup> Ohm	
Insulation Resistance(500°F/260°C)	≥ 10 <sup>9</sup> Ohm	≥ 10 <sup>9</sup> Ohm	
<b>Physical</b>			
Sensing Element	Quartz	Quartz	
Sensing Geometry	Compression	Compression	
Housing Material	17-4 Stainless Steel	17-4 Stainless Steel	
Diaphragm	316L Stainless Steel	316L Stainless Steel	
Sealing	Welded Hermetic	Welded Hermetic	
Electrical Connector	10-32 Coaxial Jack	10-32 Coaxial Jack	
Weight	0.21 oz	6.0 gm	

## OPTIONAL VERSIONS

Optional versions have identical specifications and accessories as listed for the standard model except where noted below. More than one option may be used.

- P** - Positive Output Polarity  
Output Polarity(Positive Pressure) Positive Positive [4]
- W** - Water Resistant Cable  
Supplied Accessory: Model 060A03 Clamp nut, 5/16-24-2A thd, 1/4" hex, stainless steel (1) [4]
- WM** - Water Resistant Cable  
Supplied Accessory: Model 060A05 Clamp nut M7 x 0.75-6g thd (1)

## NOTES:

- [1]Zero-based, least-squares, straight line method.  
[2]Typical.  
[3]See PCB Declaration of Conformance PS158 for details.  
[4]Clamp nut installed prior to cable attachment

## SUPPLIED ACCESSORIES:

- Model 060A03 Clamp nut, 5/16-24-2A thd, 1/4" hex, stainless steel (1)  
Model 060A05 Clamp nut M7 x 0.75-6g thd (1)  
Model 065A02 Seal ring, sensor flush mount, 0.248" OD x 0.219" ID x 0.015" thk, brass (3)  
Model 065A05 Seal sleeve sensor recess mount 0.248" OD x 0.221" ID x 0.240" thk 17-7 (1)  
Model 065A29 Seal, .250" OD x .218" ID x .015", 316L (2)  
Model PCS-10 Single point sensitivity coefficient at sensor maximum operating temperature  
Model PCS-1BA Sensitivity calibration at 100%, 10% and 2% of sensor range

Entered: ND	Engineer: AJA	Sales: RWM	Approved: RPF	Spec Number:
Date: 07/16/2024	Date: 07/16/2024	Date: 07/16/2024	Date: 07/16/2024	69803

**PCB PIEZOTRONICS**  
AN AMPHENOL COMPANY  
Phone: 716-684-0001  
Fax: 716-684-0987  
E-Mail: info@pcb.com

3425 Walden Avenue, Depew, NY 14043

Typical Sensitivity Deviation vs Temperature

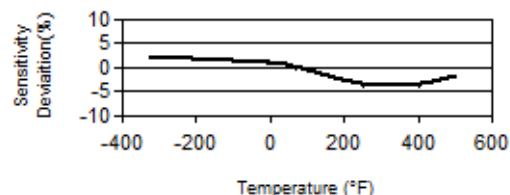

All specifications are at room temperature unless otherwise specified.  
In the interest of constant product improvement, we reserve the right to change specifications without notice.  
ICP® is a registered trademark of PCB Piezotronics, Inc.

112-1040-90

PCB Piezotronics Inc. claims proprietary rights in the information disclosed hereon. Neither it nor any reproduction thereof will be disclosed to others without the written consent of PCB Piezotronics Inc.

REVISIONS		
REV	DESCRIPTION	DIN
P	065A29 WAS 065A26	49559

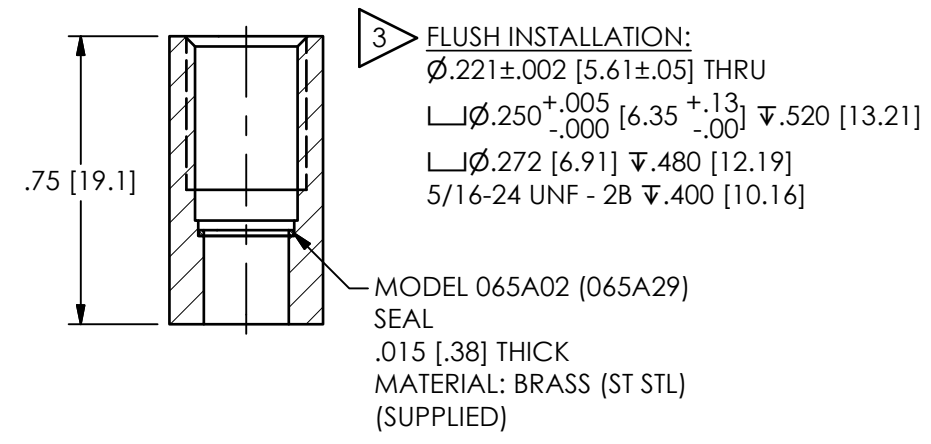
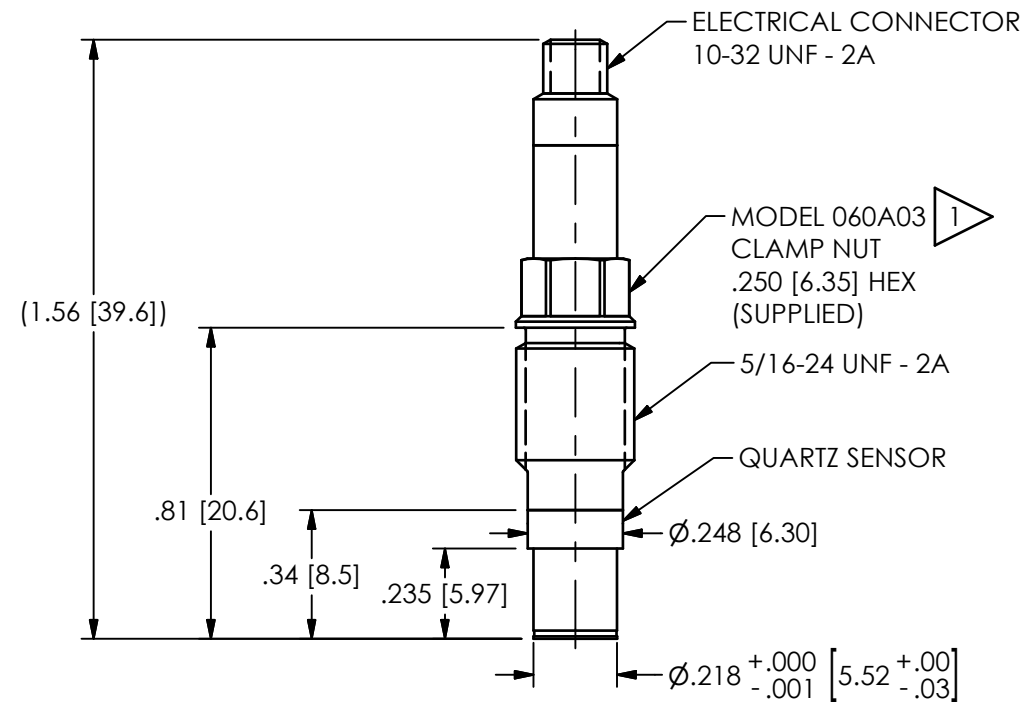

**MOUNTING HOLE PREPARATION**

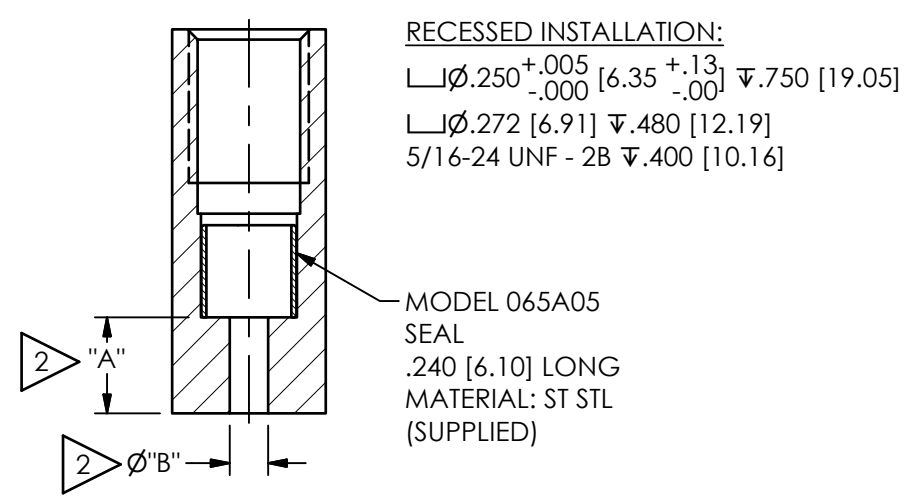

**MOUNTING HOLE PREPARATION**

- 3 THESE DIMENSIONS FOR .75 [19.1] THICK WALL, L THICKER WALLS TO THIS DIMENSION
- 2 DIMENSIONS "A" AND Ø"B" TO SUIT USER REQUIREMENTS
- 1 RECOMMENDED TORQUE ON CLAMP NUT 23-35 INCH POUNDS [225-395 Ncm]

UNLESS OTHERWISE SPECIFIED TOLERANCES ARE:		DRAWN		CHECKED		ENGINEER	
DIMENSIONS IN INCHES	DIMENSIONS IN MILLIMETERS [IN BRACKETS]	JES	5/22/19	JES	5/22/19	NJL	5/22/19
DECIMALS XX ±.01 XXX ±.005	DECIMALS X ±.03 XX ±.013	TITLE INSTALLATION DRAWING 112 SERIES HIGH TEMPERATURE PRESSURE SENSORS					
ANGLES ± 2 DEGREES	ANGLES ± 2 DEGREES						
FILLETS AND RADII .003 - .005	FILLETS AND RADII 0.07 - 0.13						

**PCB PIEZOTRONICS™**  
 3425 WALDEN AVE. DEPEW, NY 14043  
 (716) 684-0001 E-MAIL: sales@pcb.com

CODE IDENT. NO. 52681  
 DWG. NO. 112-1040-90

SCALE: 2X SHEET 1 OF 1



36450

PCB Piezotronics Inc. claims proprietary rights in the information disclosed hereon. Neither it nor any reproduction thereof will be disclosed to others without the written consent of PCB Piezotronics Inc.

REVISIONS		
REV	DESCRIPTION	DIN
D	UPDATED OVERALL LENGTH DIMENSION	53183

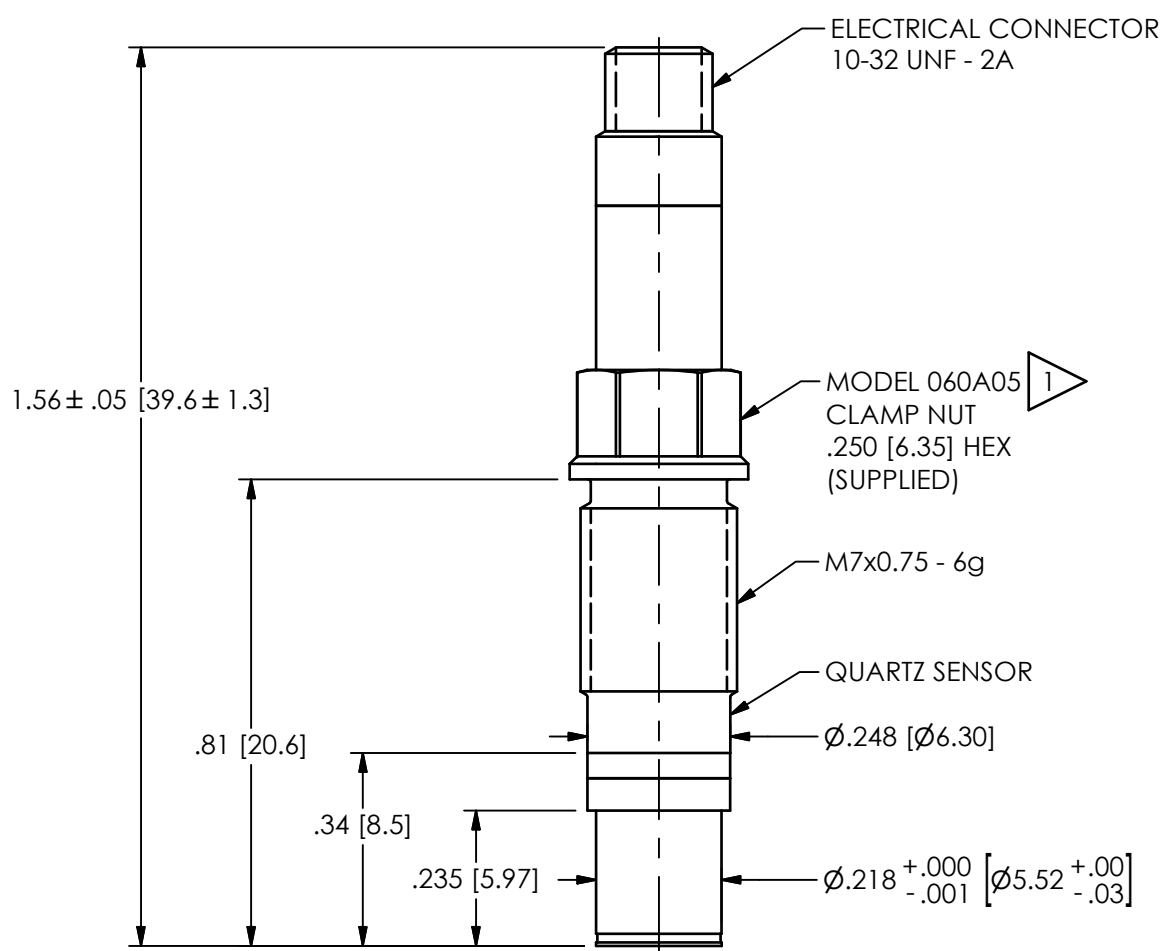

**MOUNTING HOLE PREPARATION**

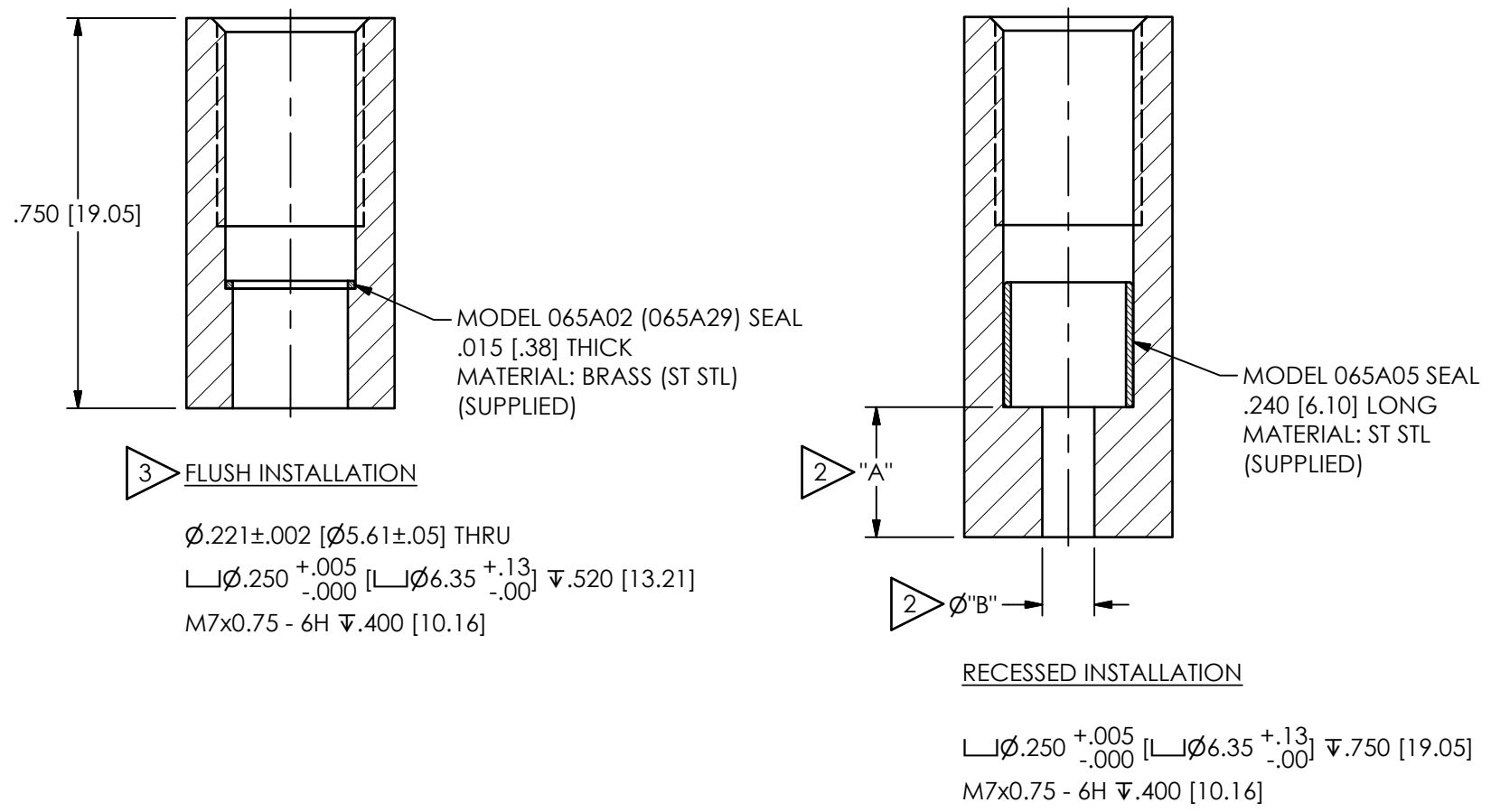

- 3 THESE DIMENSIONS FOR .75 [19.1] THICK WALL, □ THICKER WALLS TO THIS DIMENSION
- 2 DIMENSIONS "A" AND Ø"B" TO SUIT USER REQUIREMENTS
- 1 RECOMMENDED TORQUE ON CLAMP NUT 23-35 IN-LBS [225-395 N-cm]

UNLESS OTHERWISE SPECIFIED TOLERANCES ARE:		DRAWN		CHECKED		ENGINEER			
DIMENSIONS IN INCHES DECIMALS XX ±.01 XXX ±.005 ANGLES ± 2 DEGREES		DIMENSIONS IN MILLIMETERS [ IN BRACKETS ] DECIMALS X ± 0.3 XX ± 0.13 ANGLES ± 2 DEGREES		NJF	10/04/22	JDM	10/04/22	AJA	10/04/22
CABLE TOLERANCES IN ENGLISH 1"≤ LENGTH < 1' = +1' / - 0 1'≤ LENGTH < 5' = +2' / - 0 5'≤ LENGTH < 100' = +6' / - 0 100'≤ LENGTH = +1' / - 0		CABLE TOLERANCES IN METRIC 2.54cm ≤ LENGTH < 30.5cm = +2.54cm / - 0 30.5cm ≤ LENGTH < 1.5m = +5.1cm / - 0 1.5m ≤ LENGTH < 30.5m = +15.2cm / - 0 30.5m ≤ LENGTH = +30.5cm / - 0		TITLE INSTALLATION DRAWING M112 SERIES PRESSURE SENSORS					
FILLETS AND RADII .003 - .005		FILLETS AND RADII 0.07 - 0.13		CODE IDENT. NO. 52681		DWG. NO. 36450		SCALE: 3X SHEET 1 OF 1	

**PCB PIEZOTRONICS**  
AN AMPHENOL COMPANY

3425 WALDEN AVE. DEPEW, NY 14043  
(716) 684-0001 E-MAIL: sales@pcb.com