



Model 108A04

Hydraulic pump ICP® pressure sensor, 30k psi, 0.15 mV/psi (long life integral diaphragm)

Installation and Operating Manual

**For assistance with the operation of this product,
contact the PCB Piezotronics, Inc.**

Toll-free: 716-684-0001

24-hour SensorLine: 716-684-0001

Fax: 716-684-0987

E-mail: info@pcb.com

Web: www.pcb.com



Repair and Maintenance

PCB guarantees Total Customer Satisfaction through its “Lifetime Warranty Plus” on all Platinum Stock Products sold by PCB and through its limited warranties on all other PCB Stock, Standard and Special products. Due to the sophisticated nature of our sensors and associated instrumentation, **field servicing and repair is not recommended and, if attempted, will void the factory warranty.**

Beyond routine calibration and battery replacements where applicable, our products require no user maintenance. Clean electrical connectors, housings, and mounting surfaces with solutions and techniques that will not harm the material of construction. Observe caution when using liquids near devices that are not hermetically sealed. Such devices should only be wiped with a dampened cloth—never saturated or submerged.

In the event that equipment becomes damaged or ceases to operate, our Application Engineers are here to support your troubleshooting efforts 24 hours a day, 7 days a week. Call or email with model and serial number as well as a brief description of the problem.

Calibration

Routine calibration of sensors and associated instrumentation is necessary to maintain measurement accuracy. We recommend calibrating on an annual basis, after exposure to any extreme environmental influence, or prior to any critical test.

PCB Piezotronics is an ISO-9001 certified company whose calibration services are accredited by A2LA to ISO/IEC 17025, with full traceability to SI through N.I.S.T. In addition to our standard calibration services, we also offer specialized tests, including: sensitivity at elevated or cryogenic temperatures, phase response, extended high or low frequency response, extended range, leak testing, hydrostatic pressure testing, and others. For more information, contact your local PCB Piezotronics distributor, sales representative, or factory customer service representative.

Returning Equipment

If factory repair is required, our representatives will provide you with a Return Material Authorization (RMA) number, which we use to reference any information you have already provided and expedite the repair process. This number should be clearly marked on the outside of all returned package(s) and on any packing list(s) accompanying the shipment.

Contact Information

PCB Piezotronics, Inc.
3425 Walden Ave.
Depew, NY14043 USA
Toll-free: (800) 828-8840
24-hour SensorLine: (716) 684-0001
General inquiries: info@pcb.com
Repair inquiries: rma@pcb.com

For a complete list of distributors, global offices and sales representatives, visit our website, www.pcb.com.

Safety Considerations

This product is intended for use by qualified personnel who recognize shock hazards and are familiar with the precautions required to avoid injury. While our equipment is designed with user safety in mind, the protection provided by the equipment may be impaired if equipment is used in a manner not specified by this manual.

Discontinue use and contact our 24-Hour Sensorline if:

- Assistance is needed to safely operate equipment
- Damage is visible or suspected
- Equipment fails or malfunctions

For complete equipment ratings, refer to the enclosed specification sheet for your product.

Definition of Terms and Symbols

The following symbols may be used in this manual:



DANGER

Indicates an immediate hazardous situation, which, if not avoided, may result in death or serious injury.

**CAUTION**

Refers to hazards that could damage the instrument.

**NOTE**

Indicates tips, recommendations and important information. The notes simplify processes and contain additional information on particular operating steps.

The following symbols may be found on the equipment described in this manual:



This symbol on the unit indicates that high voltage may be present. Use standard safety precautions to avoid personal contact with this voltage.



This symbol on the unit indicates that the user should refer to the operating instructions located in the manual.



This symbol indicates safety, earth ground.



PCB工业监视和测量设备 - 中国RoHS2公布表

PCB Industrial Monitoring and Measuring Equipment - China RoHS 2 Disclosure Table

部件名称	有害物质					
	铅 (Pb)	汞 (Hg)	镉 (Cd)	六价铬 (Cr(VI))	多溴联苯 (PBB)	多溴二苯醚 (PBDE)
住房	0	0	0	0	0	0
PCB板	X	0	0	0	0	0
电气连接器	0	0	0	0	0	0
压电晶体	X	0	0	0	0	0
环氧	0	0	0	0	0	0
铁氟龙	0	0	0	0	0	0
电子	0	0	0	0	0	0
厚膜基板	0	0	X	0	0	0
电线	0	0	0	0	0	0
电缆	X	0	0	0	0	0
塑料	0	0	0	0	0	0
焊接	X	0	0	0	0	0
铜合金/黄铜	X	0	0	0	0	0
本表格依据 SJ/T 11364 的规定编制。						
0：表示该有害物质在该部件所有均质材料中的含量均在 GB/T 26572 规定的限量要求以下。						
X：表示该有害物质至少在该部件的某一均质材料中的含量超出 GB/T 26572 规定的限量要求。						
铅是欧洲RoHS指令2011/65/ EU附件三和附件四目前由于允许的豁免。						

CHINA RoHS COMPLIANCE

Component Name	Hazardous Substances					
	Lead (Pb)	Mercury (Hg)	Cadmium (Cd)	Chromium VI Compounds (Cr(VI))	Polybrominated Biphenyls (PBB)	Polybrominated Diphenyl Ethers (PBDE)
Housing	O	O	O	O	O	O
PCB Board	X	O	O	O	O	O
Electrical Connectors	O	O	O	O	O	O
Piezoelectric Crystals	X	O	O	O	O	O
Epoxy	O	O	O	O	O	O
Teflon	O	O	O	O	O	O
Electronics	O	O	O	O	O	O
Thick Film Substrate	O	O	X	O	O	O
Wires	O	O	O	O	O	O
Cables	X	O	O	O	O	O
Plastic	O	O	O	O	O	O
Solder	X	O	O	O	O	O
Copper Alloy/Brass	X	O	O	O	O	O

This table is prepared in accordance with the provisions of SJ/T 11364.

O: Indicates that said hazardous substance contained in all of the homogeneous materials for this part is below the limit requirement of GB/T 26572.

X: Indicates that said hazardous substance contained in at least one of the homogeneous materials for this part is above the limit requirement of GB/T 26572.

Lead is present due to allowed exemption in Annex III or Annex IV of the European RoHS Directive 2011/65/EU.

OPERATION MANUAL FOR ICP® HIGH PRESSURE SENSORS Series 108 & 109

1.0 INTRODUCTION

The 108 & 109 Series are acceleration-compensated, high pressure, ICP® (Integrated Circuit Piezoelectric) sensors primarily developed to measure ballistics chamber pressures for R & D and production testing of ammunition. They may also be used for explosive air blast and other high pressure measurements in extreme shock environments where ultra-fast, micro-second response is required. These types of tests are usually accompanied by large acceleration pulses, which can add considerable error to output signals of un-compensated sensors.

The shoulder seal design features a one-piece diaphragm machined integral with the housing for ruggedness.

For applications where strain sensitivity from stress within the mounting port is a concern, the 108A1X, 108B1X, 109B1X and 109C1X utilize a floating clamp-nut design to reduce the effects, where "X" denotes pressure range.

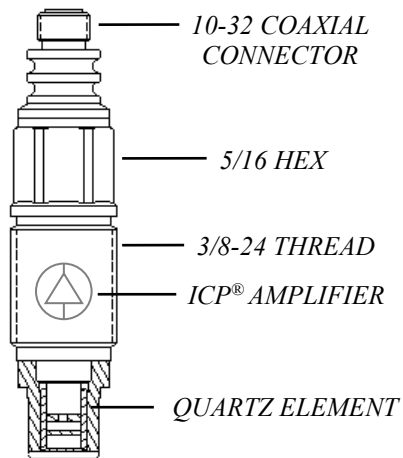

2.0 DESCRIPTION

The 108 & 109 Series contain an acceleration-compensated piezo element, which is coupled to a microelectronic amplifier. The quartz element contains an integral seismic mass that counteracts the acceleration effects of the end piece and diaphragm. This compensation acts to extend the frequency characteristics and enhance the transient response of the sensor.

The machined diaphragm is made from maraging steel, selected because of its high strength and durability. The combination of the short, rigid element and stiff diaphragm give these sensors a high natural frequency and linearity.

The microelectronic amplifier converts the high-impedance voltage from the quartz package into a

low-impedance, high-level output signal. See the Technical Information section of our website for more complete coverage of ICP® instruments.

3.0 INSTALLATION

With a 3/8-24 (M10x1.0 for metric mount) mounting thread and flush diaphragm design, the 108 & 109 Series transducers mount directly in existing ports machined for PCB Series 118 & 119.

Unlike conventional diaphragm type sensors, the 108 & 109 Series are pressure sensitive over the entire frontal area. Extra care should be exercised to avoid bottoming in the mounting hole when recess mounted or when mounting into existing ports.

Install the sensor, using only one of the seals provided, with the aid of a torque wrench to monitor the mounting torque value. The recommended torque range can be found on the installation drawing. Seals should be replaced each time the sensor is re-installed.

3.1 MOUNTING IN EXISTING RECESSED PORTS

Before installing the sensor in previously used mounting ports, clean out the residue from previous tests. The port can be cleaned by hand reaming the ¼ inch diameter hole using a PCB Model 040A end cutting reamer (040A07 for metric mount) guided by PCB Model 041A pilot bushing (M041A for metric mount).

Pay particular attention to the sealing surface, keeping it free from tool chatter marks, nicks and other imperfections that could adversely affect the seal. If the sealing surface requires re-machining after prolonged use, refer to the installation drawing to ensure that the ¼ inch hole is deepened to avoid bottoming of the sensor when re-installed.

**OPERATION MANUAL FOR
ICP® HIGH PRESSURE SENSORS
Series 108 & 109**

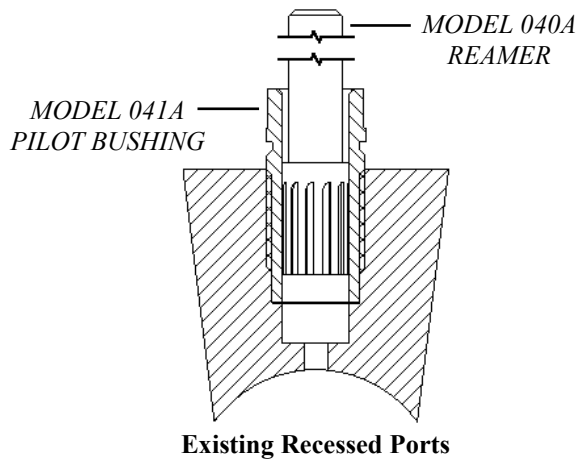

If waveform distortion occurs during prolonged testing, remove the sensor and clean the residue as illustrated above.

3.2 PREPARING NEW MOUNTING PORTS

Refer to the installation drawing provided in this manual for instructions on mounting hole preparation. For best results, do not deviate from the steps outlined in this drawing.

To assist new mounting port preparation, PCB offers the 040B20 Tooling Kit (040B21 for metric mount). These installation kits provide all of the necessary tooling required to drill, ream, and tap the mounting ports for proper installation of the 108, 109, 118 and 119 Series transducers.

Use good machining practice in preparation of the mounting port, paying particular attention to the seal surface. It is important that this surface be perfectly smooth and free from tool chatter marks, nicks and other imperfections which might cause leaks at high pressures.

3.3 RECESSED MOUNT

The recessed installation is shown in the Recessed Mount figure. This type of mounting protects the sensor diaphragm from the effects of high-flash temperatures and particle impingement due to blast effects, thereby prolonging sensor life.

The recommended range of passage diameters is 0.090 to 0.125 inch (2.29 to 3.18 mm) diameter.

The limitation in this type of installation lies in the frequency-limiting effects of the passage due to its length.

The passage behaves like an underdamped second order system; the resonant frequency being determined by the passage length. The length may have a limiting effect on pressure pulse rise time and cause passage ringing in cases where the passage is too long.

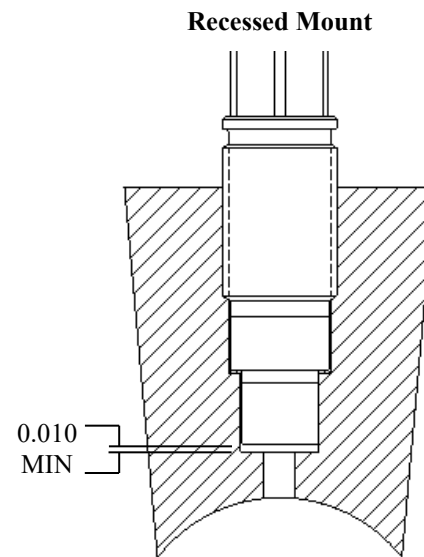

The following relationship approximates this resonant frequency (f_r):

$$f_r = \frac{V}{4L} \quad (\text{Hz}) \quad (\text{EQ. 1})$$

Where: f_r = Resonant frequency of passage (Hz)

V = Velocity of sound in air (ft/sec)

L = Length of column (ft)

For air at room temperature, (EQ. 1) becomes:

$$f_r = \frac{3300}{L} \quad (\text{EQ. 2})$$

Where: L = Passage length (in)

The natural frequency and approximate fastest pressure step rise time for various length passages is shown in the following chart. (Medium, air at 25°C).

**OPERATION MANUAL FOR
ICP® HIGH PRESSURE SENSORS
Series 108 & 109**

PASSAGE LENGTH (in)	PASSAGE RESONANCE (kHz)	APPROX. FASTEST PULSE RISE TIME (μsec)
.050	66	5
.100	33	10
.200	16.5	20
.50	6.6	50
1.0	3.3	100

Passage Resonance vs. Passage Length

Actual resonant frequencies measured in practice may differ slightly from the chart values. These differences are due to variations in the velocity of propagation of sound in air caused by changes in temperature and pressure of the air in the passage.

For best matching of passage to diaphragm, maintain the 0.010 inch (0.254 mm) clearance ahead of the diaphragm as shown in the Recessed Mount figure on the previous page.

3.4 FLUSH MOUNT

In the flush mount installation, there is no reduced area passage from the sensor diaphragm to the test chamber; rather the sensor diaphragm is mounted flush with (or slightly recessed from) the inside surface of the test chamber.

Use this type of installation only if space or rise time considerations preclude the use of recessed installation.

In severe pyrotechnic environments, sensor life may be severely limited with flush installation.

3.5 FLASH TEMPERATURE EFFECTS

If more protection from flash thermal effects is required with the recessed mount, the passage can be filled with silicone grease (DC-4 or equivalent). Several layers of black vinyl electrical tape directly on the diaphragm have proven effective in many cases as well.

Flash temperature effects are usually longer term and will show up as a baseline shift long after the event to be measured has passed.

For flush mount installations, a silicone rubber coating approximately 0.010 inch thick can be effective; RTV 106 is recommended, and is available from PCB as Model 065A67. Follow manufacturer's instructions to apply. It is best to recess the diaphragm 0.010 inch for this type of protection.

3.6 INSTALLING CABLES

It is convenient, though not necessary, to use coaxial cable, such as PCB 002 Series, to connect the transducer to the power unit. Cable need not be low-noise treated.

If the use of lighter, more flexible cable is desired, PCB Model 070B09 solder connector adaptors may be used to employ twisted pair or other types of two-wire cable.

OPERATION MANUAL FOR ICP® HIGH PRESSURE SENSORS Series 108 & 109

3.7 CIRCUIT CONNECTIONS

The figures below show two typical circuit connections normally used to connect the 108 & 109 Series to power units.

The first figure is the connection scheme used for most applications. In this set up, the signal is AC-coupled from the bias voltage meaning the voltage at the "scope" terminal will be at a zero volt bias level.

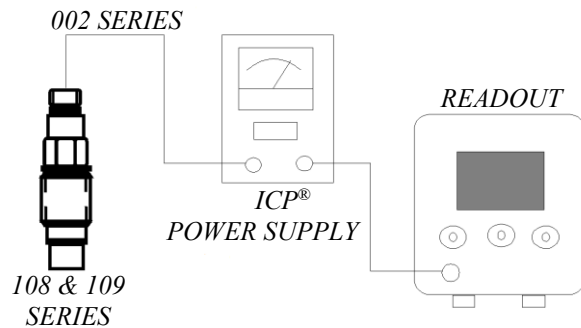

Normal Connection AC-Coupled Output

In this case, the system discharge time constant will be determined by the input resistance and capacitance of the power unit. Most PCB power units have approximately a 10 second discharge time constant.

Alternate Connection to take Advantage of Sensor Discharge TC

The second figure illustrates an optional connection scheme which can be used during calibration to take full advantage of the sensor's discharge time constant.

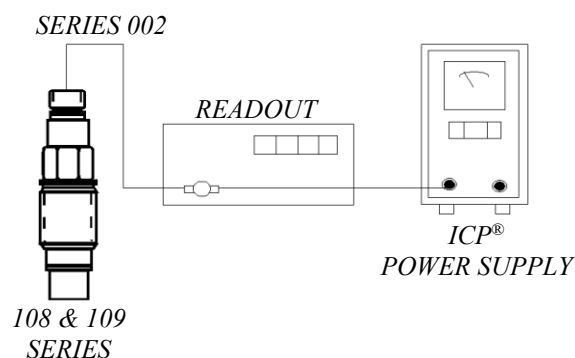

With this arrangement, the readout is direct-coupled to the sensor and the output signal will be added to the DC bias voltage (11 VDC nominal).

The discharge time constant will then be determined only by the sensor and should be in the order of 2000 seconds; this is sufficient for most types of static calibration methods. (See Calibration Section 4.0)

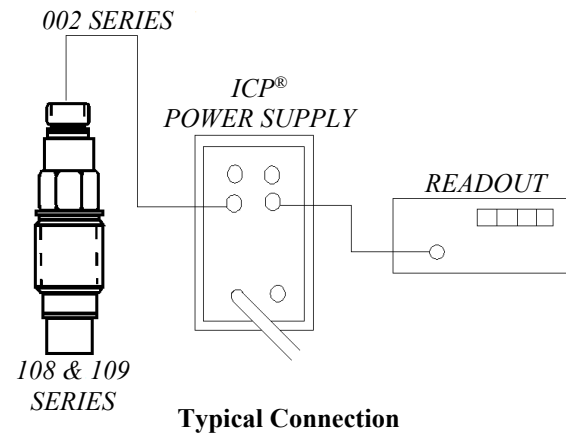

The figure above shows the 108 & 109 Series connected to a PCB Model 484B06 power unit. The 484B06 is a power unit that can be AC or DC-coupled.

In the DC-couple mode, a level-shifting circuit removes the bias level and provides a zero adjust feature at the front panel. The system's discharge time constant is determined by the sensor in this mode.

An AC-coupled mode is provided for normal AC-coupled operation.

4.0 CALIBRATION

PCB 108 & 109 Series sensors are supplied with a calibration certification from the factory. Recalibration services are provided at the factory for a nominal fee.

Static calibration methods may be employed using the set-up shown in the Alternate Connection figure or by use of the Model 484B06 Power Unit as shown in the figure above – use the 484B06 in DC mode.

Following thermal stabilization of the sensor, use a high pressure pump with dial reference sensor or a dead weight tester to apply pressure in desired increments to full scale. Release pressure after taking the reading and before proceeding to the next higher pressure level.

With a 2000 second discharge time constant, 1% of the signal will be lost in 20 seconds, so it is imperative that the pressure setting and recording of output be accomplished quickly.

A calibration graph can be plotted using output voltage vs. input pressure to determine sensitivity and linearity.

OPERATION MANUAL FOR ICP® HIGH PRESSURE SENSORS Series 108 & 109

5.0 OPERATION

Select desired mode of circuit connection and turn power unit on.

Observe fault monitor meter at the front panel of the power unit.

Normal operation is indicated by an approximate midscale reading. Shorted cable or connections are indicated by a zero reading (red area).

Open cable or connections are indicated by a full-scale (yellow area) reading.

Allow instrument several minutes to warm up and thermally stabilize.

When output from the power unit is connected to readout equipment, a drift in the voltage signal will be noticed; this is normal. This voltage signal drift is caused by the charging of the coupling capacitor in the power unit and will cease within several minutes.

6.0 POLARITY

The 108 & 109 Series are designed to produce a positive output voltage for increasing pressure at the diaphragm.

7.0 MAINTENANCE

The small size and sealed construction of the 108 & 109 Series precludes field maintenance and repair. Contact the factory for further assistance.

Performance	ENGLISH	SI	OPTIONAL VERSIONS	
Measurement Range (for $\pm 4.5V$ output)	30 kpsi	207,000 kPa	Optional versions have identical specifications and accessories as listed for the standard model except where noted below. More than one option may be used.	
Sensitivity ($\pm 15\%$)	0.15 mV/psi	0.022 mV/kPa	M - Metric Mount	
Maximum Pressure	50 kpsi	344,750 kPa	N - Negative Output Polarity	
Resolution	500 mpsi	3.5 kPa	W - Water Resistant Cable	
Resonant Frequency	≥ 250 kHz	≥ 250 kHz		
Rise Time (Reflected)	$\leq 2 \mu$ sec	$\leq 2 \mu$ sec		
Low Frequency Response (-5%)	0.002 Hz	0.002 Hz		
Non-Linearity	$\leq 2\%$ FS	$\leq 2\%$ FS		
Environmental				
Acceleration Sensitivity	≤ 0.05 psi/g	≤ 0.035 kPa/(m/s ²)		
Temperature Range (Operating)	-100 to +275 °F	-73 to +135 °C		
Temperature Coefficient of Sensitivity	$\leq 0.10\%$ /°F	$\leq 0.18\%$ /°C		
Maximum Vibration	2000 g pk	19,614 m/s ² pk		
Maximum Shock	20,000 g pk	196,140 m/s ² pk		
Electrical				
Output Polarity (Positive Pressure)	Positive	Positive		
Discharge Time Constant (at room temp)	≥ 250 sec	≥ 250 sec		
Excitation Voltage	20 to 30 VDC	20 to 30 VDC		
Constant Current Excitation	2 to 20 mA	2 to 20 mA		
Output Impedance	≤ 100 ohm	≤ 100 ohm		
Output Bias Voltage	8 to 14 VDC	8 to 14 VDC		
Physical				
Sensing Geometry	Compression	Compression		
Sensing Element	Quartz	Quartz		
Housing Material	C-300	C-300		
Diaphragm	C-300	C-300		
Sealing	Welded Hermetic	Welded Hermetic		
Electrical Connector	10-32 Coaxial Jack	10-32 Coaxial Jack		
Weight	0.48 oz	13.6 gm		
			NOTES:	
			[1] Zero-based, least-squares, straight line method.	
			[2] See PCB Declaration of Conformance PS023 for details.	
			SUPPLIED ACCESSORIES:	
			Model 065A06 Seal ring 0.318" OD x 0.250" ID x 0.010" thk 316L SS material (3)	
			Entered: <i>BLS</i>	Engineer: <i>NJL</i>
			Sales: <i>DPC</i>	Approved: <i>RF</i>
			Date: <i>4-4-05</i>	Date: <i>4/4/05</i>
			Date: <i>4/4/05</i>	Spec Number: <i>28544</i>
			 PCB PIEZOTRONICS™ PRESSURE DIVISION Phone: 716-684-0001 Fax: 716-686-9129 E-Mail: pressure@pcb.com 3425 Walden Avenue, Depew, NY 14043	



[2]

All specifications are at room temperature unless otherwise specified.
 In the interest of constant product improvement, we reserve the right to change specifications without notice.

ICP® is a registered trademark of PCB Group, Inc.

108-1020-90

PCB Piezotronics Inc. claims proprietary rights in the information disclosed hereon. Neither it nor any reproduction thereof will be disclosed to others without the written consent of PCB Piezotronics Inc.

REVISIONS		
REV	DESCRIPTION	DIN
H	CORRECTED MOUNTING HOLES	51799

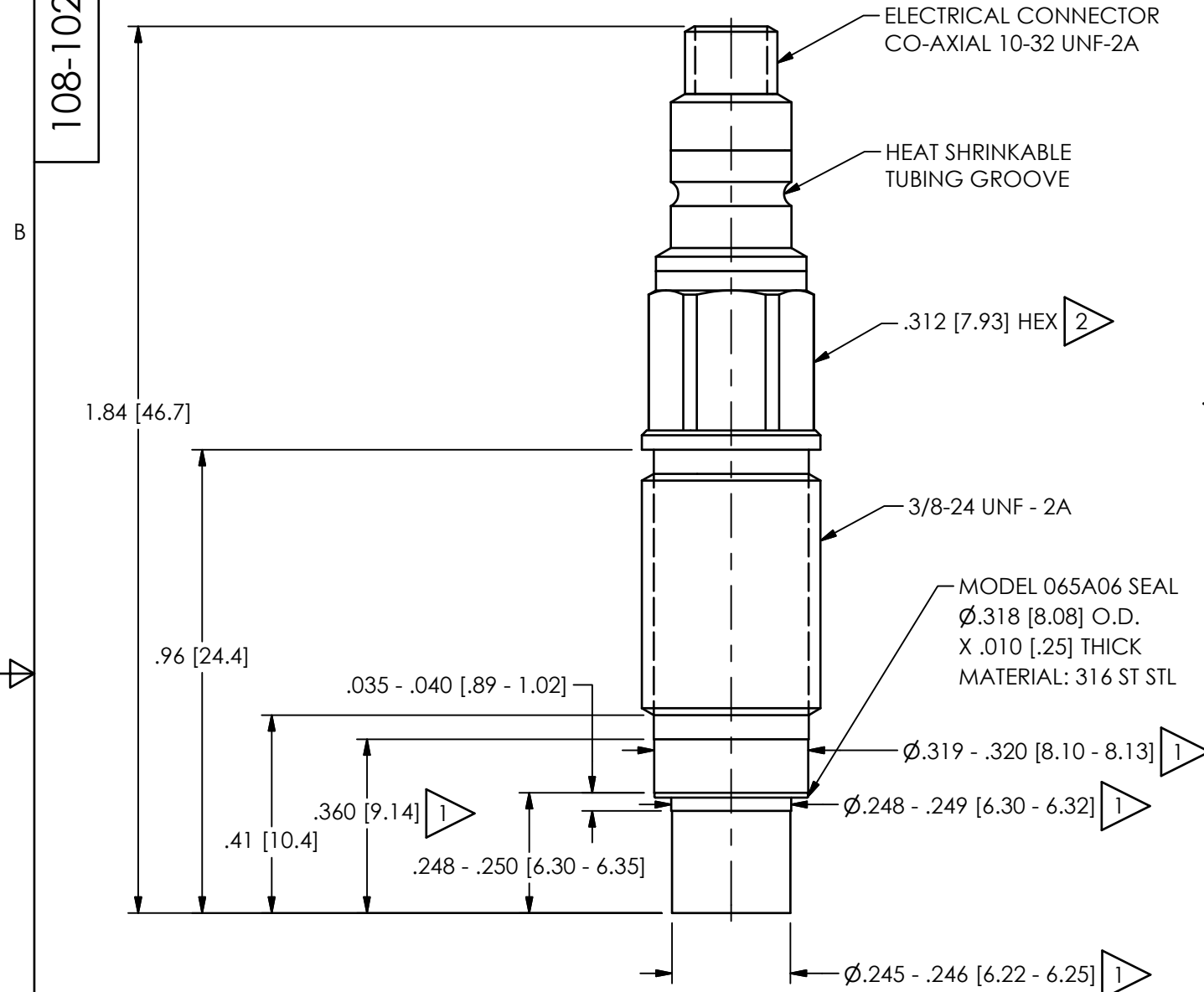

FLUSH INSTALLATION

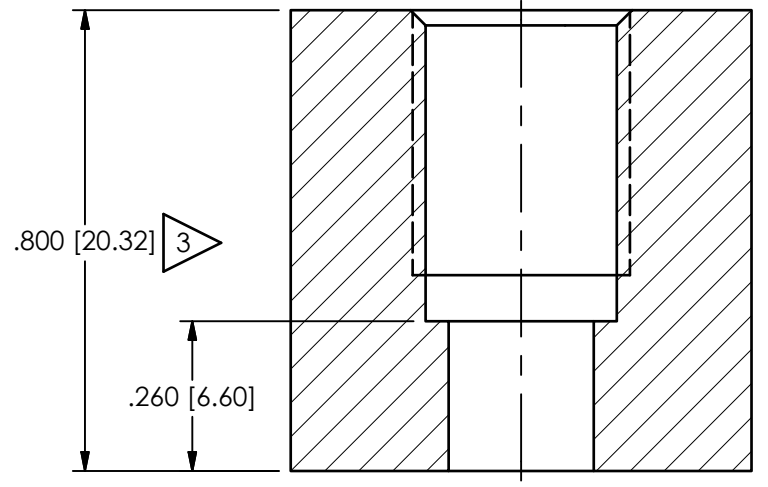

RECESSED INSTALLATION

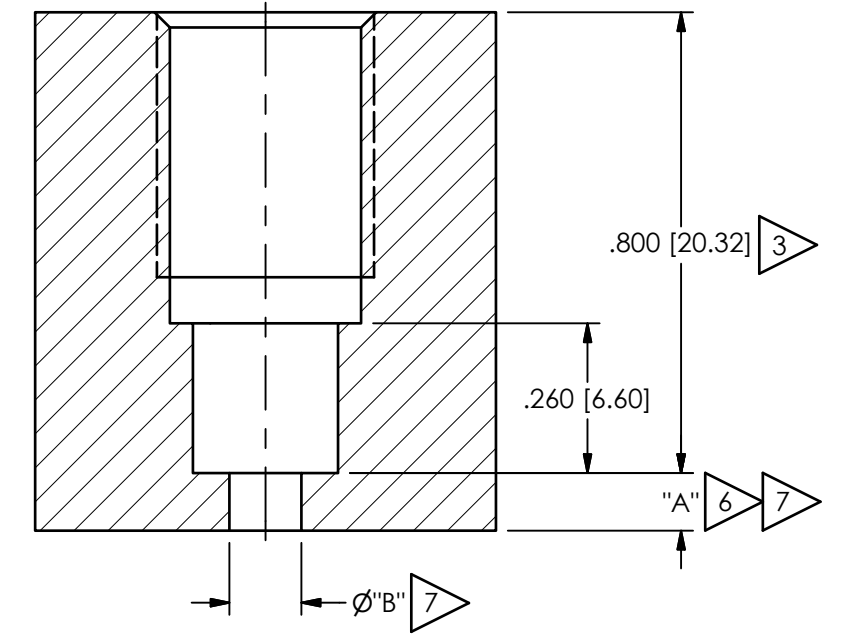

MOUNTING HOLE DIMENSIONS

- 3 5 Ø.252 ±.001 [6.40 ±.03] THRU
- 4 5 LØ.332 ±.001 [8.43 ±.03] (▽.540 [13.72])
- 8 3/8-24 UNF-2B (▽.460 [11.68])

MOUNTING HOLE DIMENSIONS

- 3 5 Ø.252 ±.001 [6.40 ±.03] (▽.800 [20.32])
- 4 5 LØ.332 ±.001 [8.43 ±.03] (▽.540 [13.72])
- 8 3/8-24 UNF-2B (▽.460 [11.68])

- 8 CAUTION: DO NOT TOUCH SEAL SURFACE WITH TAP WHEN TAPPING HOLE
- 7 DIMENSION "A" & "B" TO SUIT USER REQUIREMENTS
- 6 KEEP "A" AS SHORT AS POSSIBLE, SEE OPERATING GUIDE FOR OPTIMUM PASSAGE LENGTH
- 5 THESE DIAMETERS TO BE CONCENTRIC WITHIN .001 [.03] TIR
- 4 SEAL SURFACE SHOULD BE FLAT AND FREE OF TOOL MARKS WITH A MINIMUM FINISH OF 63 [1.6] FOR BEST RESULTS
- 3 DIMENSIONS SHOWN ARE FOR .800 [20.32] WALL THICKNESS. C'BORE FOR THICKER WALL
- 2 RECOMMENDED MOUNTING TORQUE ON .312 [7.93] HEX: 20-25 FT-LBS [27-34 Nm]
- 1 MATERIAL: C-300 MARAGING STEEL

UNLESS OTHERWISE SPECIFIED TOLERANCES ARE:		DRAWN		CHECKED		ENGINEER	
DIMENSIONS IN INCHES	DIMENSIONS IN MILLIMETERS [IN BRACKETS]	JJF	5/21/21	JJF	5/21/21	NJL	5/21/21
DECIMALS XX ±.01 XXX ±.005	DECIMALS X ±.03 XX ±.013	TITLE INSTALLATION DRAWING MODEL 108A02, 108A04 HERMETICALLY SEALED PRESSURE SENSOR					
ANGLES ± 2 DEGREES	ANGLES ± 2 DEGREES						
FILLETS AND RADII .003 - .005	FILLETS AND RADII 0.07 - 0.13	CODE IDENT. NO. 52681		DWG. NO. 108-1020-90		SCALE: 3X SHEET 1 OF 1	

PCB PIEZOTRONICS
3425 WALDEN AVE. DEPEW, NY 14043
(716) 684-0001 E-MAIL: sales@pcb.com