



**Model 105C22**

**Subminiature ICP® pressure sensor, 1 mV/psi, 0.099" dia. diaphragm, 10-32 mtg thd**

**Installation and Operating Manual**

**For assistance with the operation of this product,  
contact the PCB Piezotronics, Inc.**

**Toll-free: 716-684-0001  
24-hour SensorLine: 716-684-0001  
Fax: 716-684-0987  
E-mail: [info@pcb.com](mailto:info@pcb.com)  
Web: [www.pcb.com](http://www.pcb.com)**



## Repair and Maintenance

PCB guarantees Total Customer Satisfaction through its “Lifetime Warranty Plus” on all Platinum Stock Products sold by PCB and through its limited warranties on all other PCB Stock, Standard and Special products. Due to the sophisticated nature of our sensors and associated instrumentation, **field servicing and repair is not recommended and, if attempted, will void the factory warranty.**

Beyond routine calibration and battery replacements where applicable, our products require no user maintenance. Clean electrical connectors, housings, and mounting surfaces with solutions and techniques that will not harm the material of construction. Observe caution when using liquids near devices that are not hermetically sealed. Such devices should only be wiped with a dampened cloth—never saturated or submerged.

In the event that equipment becomes damaged or ceases to operate, our Application Engineers are here to support your troubleshooting efforts 24 hours a day, 7 days a week. Call or email with model and serial number as well as a brief description of the problem.

## Calibration

Routine calibration of sensors and associated instrumentation is necessary to maintain measurement accuracy. We recommend calibrating on an annual basis, after exposure to any extreme environmental influence, or prior to any critical test.

PCB Piezotronics is an ISO-9001 certified company whose calibration services are accredited by A2LA to ISO/IEC 17025, with full traceability to SI through N.I.S.T. In addition to our standard calibration services, we also offer specialized tests, including: sensitivity at elevated or cryogenic temperatures, phase response, extended high or low frequency response, extended range, leak testing, hydrostatic pressure testing, and others. For more information, contact your local PCB Piezotronics distributor, sales representative, or factory customer service representative.

## Returning Equipment

If factory repair is required, our representatives will provide you with a Return Material Authorization (RMA) number, which we use to reference any information you have already provided and expedite the repair process. This number should be clearly marked on the outside of all returned package(s) and on any packing list(s) accompanying the shipment.

## Contact Information

PCB Piezotronics, Inc.  
3425 Walden Ave.  
Depew, NY14043 USA  
Toll-free: (800) 828-8840  
24-hour SensorLine: (716) 684-0001  
General inquiries: [info@pcb.com](mailto:info@pcb.com)  
Repair inquiries: [rma@pcb.com](mailto:rma@pcb.com)

For a complete list of distributors, global offices and sales representatives, visit our website, [www.pcb.com](http://www.pcb.com).

## Safety Considerations

This product is intended for use by qualified personnel who recognize shock hazards and are familiar with the precautions required to avoid injury. While our equipment is designed with user safety in mind, the protection provided by the equipment may be impaired if equipment is used in a manner not specified by this manual.

Discontinue use and contact our 24-Hour Sensorline if:

- Assistance is needed to safely operate equipment
- Damage is visible or suspected
- Equipment fails or malfunctions

For complete equipment ratings, refer to the enclosed specification sheet for your product.

## Definition of Terms and Symbols

The following symbols may be used in this manual:



### DANGER

Indicates an immediate hazardous situation, which, if not avoided, may result in death or serious injury.

**CAUTION**

Refers to hazards that could damage the instrument.

**NOTE**

Indicates tips, recommendations and important information. The notes simplify processes and contain additional information on particular operating steps.

**The following symbols may be found on the equipment described in this manual:**



This symbol on the unit indicates that high voltage may be present. Use standard safety precautions to avoid personal contact with this voltage.



This symbol on the unit indicates that the user should refer to the operating instructions located in the manual.



This symbol indicates safety, earth ground.



PCB工业监视和测量设备 - 中国RoHS2公布表

PCB Industrial Monitoring and Measuring Equipment - China RoHS 2 Disclosure Table

部件名称	有害物质					
	铅 (Pb)	汞 (Hg)	镉 (Cd)	六价铬 (Cr(VI))	多溴联苯 (PBB)	多溴二苯醚 (PBDE)
住房	0	0	0	0	0	0
PCB板	X	0	0	0	0	0
电气连接器	0	0	0	0	0	0
压电晶体	X	0	0	0	0	0
环氧	0	0	0	0	0	0
铁氟龙	0	0	0	0	0	0
电子	0	0	0	0	0	0
厚膜基板	0	0	X	0	0	0
电线	0	0	0	0	0	0
电缆	X	0	0	0	0	0
塑料	0	0	0	0	0	0
焊接	X	0	0	0	0	0
铜合金/黄铜	X	0	0	0	0	0
本表格依据 SJ/T 11364 的规定编制。						
0：表示该有害物质在该部件所有均质材料中的含量均在 GB/T 26572 规定的限量要求以下。						
X：表示该有害物质至少在该部件的某一均质材料中的含量超出 GB/T 26572 规定的限量要求。						
铅是欧洲RoHS指令2011/65/ EU附件三和附件四目前由于允许的豁免。						

CHINA RoHS COMPLIANCE

Component Name	Hazardous Substances					
	Lead (Pb)	Mercury (Hg)	Cadmium (Cd)	Chromium VI Compounds (Cr(VI))	Polybrominated Biphenyls (PBB)	Polybrominated Diphenyl Ethers (PBDE)
Housing	O	O	O	O	O	O
PCB Board	X	O	O	O	O	O
Electrical Connectors	O	O	O	O	O	O
Piezoelectric Crystals	X	O	O	O	O	O
Epoxy	O	O	O	O	O	O
Teflon	O	O	O	O	O	O
Electronics	O	O	O	O	O	O
Thick Film Substrate	O	O	X	O	O	O
Wires	O	O	O	O	O	O
Cables	X	O	O	O	O	O
Plastic	O	O	O	O	O	O
Solder	X	O	O	O	O	O
Copper Alloy/Brass	X	O	O	O	O	O

This table is prepared in accordance with the provisions of SJ/T 11364.

O: Indicates that said hazardous substance contained in all of the homogeneous materials for this part is below the limit requirement of GB/T 26572.

X: Indicates that said hazardous substance contained in at least one of the homogeneous materials for this part is above the limit requirement of GB/T 26572.

Lead is present due to allowed exemption in Annex III or Annex IV of the European RoHS Directive 2011/65/EU.

**OPERATION MANUAL FOR  
MINIATURE ICP<sup>®</sup> PRESSURE SENSOR  
105A AND 105C SERIES**

## **1.0 INTRODUCTION**

This model series is designed to satisfy the need for measurement of dynamic pressures where space is limited, such as in model testing.

The series consists of three basic mechanical configurations or styles, each featuring a .099" diameter diaphragm and each with a built-in impedance-converting amplifier for simple, convenient, two-wire, low-impedance operation.

## **2.0 DESCRIPTION**

The Series 105A sensors utilize two quartz discs in a thickness compression mode to produce a high-impedance level signal which is impressed across the input of a microminiature impedance converter built into the sensor housing.

The signal is superimposed upon a +11 volt (nominal) bias level at the amplifier output and is normally decoupled from the bias voltage in the power unit.

This signal can be fed directly into most common readout instruments such as oscilloscopes, digital voltmeters, AC meters, peak meters, recorders, etc. The output impedance is less than 100 ohms.

Consult guide G-0001B "General Guide to ICP<sup>®</sup> Instrumentation" for a more complete treatment of the ICP<sup>®</sup> (Integrated Circuit Piezoelectric) principle.

## **3.0 INSTALLATION**

Because of the miniature size of these units, extra care should be exercised in preparation of mounting ports and in installation of sensors into the ports.

Individual dimensional, performance and installation drawings are included in the manual for each particular model. Adhere carefully to instructions on these drawings.

It is not necessary to use low-noise treated coaxial cable as with high-impedance type sensors. PCB Model 002A Cable is recommended.

## **3.1 MODEL 105A**

This is the smallest of the three styles and it is supplied in only the 100 psi range.

The Model 105A is normally mounted using Model 060A04 Clamp Nut (supplied); however, if lack of space precludes the use of the clamp nut, the sensor may be epoxied in place if necessary.

Do not over torque clamp nut, as to do so may distort the body of the sensor and affect the sensitivity of the device.

The electrical connection to this model is made by soldering the positive (center conductor) lead from the power unit to the .040 diameter solder terminal provided.

(IMPORTANT! See Section 8.0, page 4)

NOTE: Do not overheat this terminal. Use a small iron with only enough heat to obtain good solder joint.

The electrical ground return is made to the sensor body. This connection can be made by attaching electrically to the structure or by using the metal ribbon spotwelded to the sensor body.

## **3.2 MODELS 105C02, C12 & C22**

This style utilizes a 10-32 external thread to facilitate mounting. It is supplied in three full-scale ranges: 100, 1000 and 5000 psi.

Prepare mounting port in accordance with installation drawing provided in manual. Do not over torque. Use only enough torque to obtain a seal.

The electrical connection is made via a 5-44 coaxial connector. Use coaxial 002G10 cable, 5-44 to 10-32 microdot.

**OPERATION MANUAL FOR  
MINIATURE ICP® PRESSURE SENSOR  
105A AND 105C SERIES**

**3.3 MODELS 105C03, C13, 23, C33, C43**

This style is the largest and is supplied in five models with full-scale ranges to 100, 1000, 5000, 10,000 and 30,000 psi.

The electrical connection to this style sensor is made via a 10-32 coaxial connector.

**3.4 FLASH TEMPERATURE PROTECTION**

It is good practice to protect the diaphragm against flash thermal effects, especially when flush-mounted, to minimize spurious outputs generated by high heat influx due to blasts, high compression heating, etc.

One or more layers of black vinyl electrical tape on the diaphragm can be useful for this purpose in many cases. RTV-type silicone rubber has also proven effective.

Experimentation is the best method for determination of effectiveness of protective material for each sensor application.

**3.5 RECESSED INSTALLATION**

If ultra-high frequency response is not needed, it is good practice to use a recessed diaphragm installation.

Because of its one-piece machined diaphragm construction, the 105A series is sensitive over its entire frontal area. Use extreme care when preparing recessed installation port to ensure that no particles, burrs or other residue are entrapped in the .010" gap ahead of the diaphragm. Force on the diaphragm due to such entrapped particles may change the calibration of the sensor.

Recessed mounting protects the sensor diaphragm from the effects of high-flash temperatures and particle impingement due to blast effects, thereby prolonging sensor life.

The limitation is that this type of installation lies in the high-frequency limiting effects of the passage, due to its length.

The passage behaves like an underdamped second order system, the resonant frequency being determined by the passage length. This can have a limiting effect on pressure pulse rise time while causing passage ringing in cases where the passage is too long with respect to pulse rise time. (See chart below.)

The following relationship determines this resonant frequency ( $f_r$ ):

$$f_r = \frac{V}{4L} \quad (\text{Hz}) \quad (\text{Eq. 1})$$

Where:  $f_r$  = Resonant frequency of passage (Hz)

$V$  = Velocity of sound in air (ft/sec)

$L$  = Length of column (ft)

For air at room temperature, (Eq. 1) becomes:

$$f_r = \frac{3300}{L}$$

Where  $L$  = Passage length (in.)

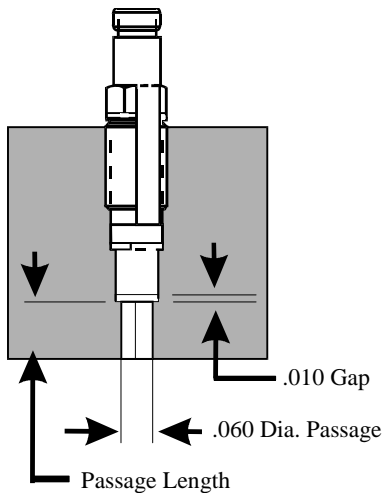

**Typical Recessed Installation**

# OPERATION MANUAL FOR MINIATURE ICP® PRESSURE SENSOR 105A AND 105C SERIES

The natural frequency and approximate fastest pressure step rise time for various length passages is shown in the following chart. (Medium, air at 25°C).

PASSAGE LENGTH (in.)	PASSAGE RESONANCE (kHz)	APPROX. FASTEST PULSE RISE TIME (u Sec)
.050	66	5
.100	33	10
.200	16.5	20
.50	6.6	50
1.0	3.3	100

### Passage Resonance vs. Passage Length

Actual resonant frequencies measured in practice may differ slightly from the chart values due to variations in the velocity of propagation of sound caused by changes in temperature and pressure of the medium in the passage.

For best matching of passage to diaphragm, maintain the .010" clearance ahead of the diaphragm as shown in Typical Recessed Installation figure.

## 4.0 OPERATION

Connect sensor to signal conditioner as shown below, depending upon sensor style being used.

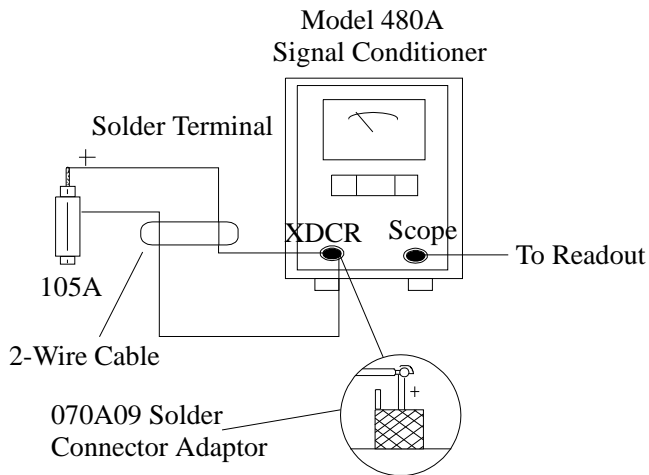

**Typical Circuit Connection (For 105A)**

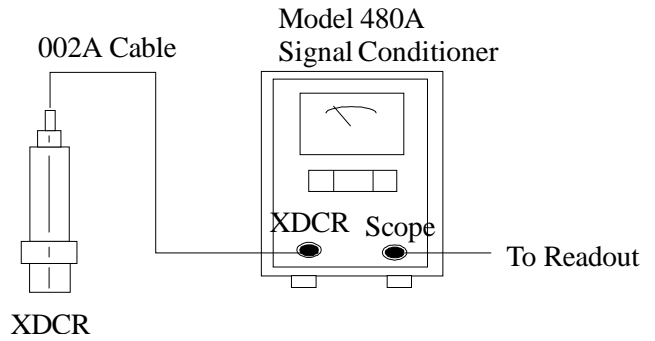

**Typical Circuit Connection (For 105C02,C03, C12, C13, C22, C23, C33, C43)**

NOTE: All PCB signal conditioners for ICP® sensor contain current-limiting circuitry to set the input current in the range of 2 to 20 mA.

Do not connect a power supply to these units without current limiting. To do so will destroy the built-in IC amplifier.

All PCB signal conditioners feature fault-monitoring voltmeters on the front panel. During normal operation, the meter will indicate about mid-scale (+11 volts). If one of the connections to the sensor is open, the meter will read full scale (yellow area). Should a short occur on the sensor line, the meter will read 0 volts (red area).

## 5.0 CALIBRATION

Because of the relatively short discharge time constant of this series, static calibration means cannot be used. Fast dynamic means such as step function or pulse generators must be used instead.

Contact the factory for help in solving specific calibration problems.

## 6.0 MAINTENANCE

The small size and sealed construction of these sensors precludes field maintenance and repair. Should a problem develop, contact the factory for assistance.



**OPERATION MANUAL FOR  
MINIATURE ICP<sup>®</sup> PRESSURE SENSOR  
105A AND 105C SERIES**

**7.0 CAUTIONS**

1. Do not apply voltage to the electrical terminals without current-limiting protection.
2. Do not apply more than 30 VDC to the sensor.
3. Do not put more than 20 mA current into the input terminals.
4. Do not overtorque sensors when installing.
5. Do not apply too much heat to the solder pin of style 1.

**8.0 TERMINAL LEAD AND GROUND**

To eliminate any possibility of overheating the solder terminal and destroying the microamplifier in the sensor, a 2.0 inch long insulated wire has been provided on the solder terminal for soldering a connector lead from the power unit. The ground return is provided by a metal ribbon (.003 x .020) welded to the Model 060A04 clamp nut.



## Repair and Maintenance

PCB guarantees Total Customer Satisfaction through its “Lifetime Warranty Plus” on all Platinum Stock Products sold by PCB and through its limited warranties on all other PCB Stock, Standard and Special products. Due to the sophisticated nature of our sensors and associated instrumentation, **field servicing and repair is not recommended and, if attempted, will void the factory warranty.**

Beyond routine calibration and battery replacements where applicable, our products require no user maintenance. Clean electrical connectors, housings, and mounting surfaces with solutions and techniques that will not harm the material of construction. Observe caution when using liquids near devices that are not hermetically sealed. Such devices should only be wiped with a dampened cloth—never saturated or submerged.

In the event that equipment becomes damaged or ceases to operate, our Application Engineers are here to support your troubleshooting efforts 24 hours a day, 7 days a week. Call or email with model and serial number as well as a brief description of the problem.

## Calibration

Routine calibration of sensors and associated instrumentation is necessary to maintain measurement accuracy. We recommend calibrating on an annual basis, after exposure to any extreme environmental influence, or prior to any critical test.

PCB Piezotronics is an ISO-9001 certified company whose calibration services are accredited by A2LA to ISO/IEC 17025, with full traceability to SI through N.I.S.T. In addition to our standard calibration services, we also offer specialized tests, including: sensitivity at elevated or cryogenic temperatures, phase response, extended high or low frequency response, extended range, leak testing, hydrostatic pressure testing, and others. For more information, contact your local PCB Piezotronics distributor, sales representative, or factory customer service representative.

## Returning Equipment

If factory repair is required, our representatives will provide you with a Return Material Authorization (RMA) number, which we use to reference any information you have already provided and expedite the repair process. This number should be clearly marked on the outside of all returned package(s) and on any packing list(s) accompanying the shipment.

## Contact Information

PCB Piezotronics, Inc.  
3425 Walden Ave.  
Depew, NY14043 USA  
Toll-free: (800) 828-8840  
24-hour SensorLine: (716) 684-0001  
General inquiries: [info@pcb.com](mailto:info@pcb.com)  
Repair inquiries: [rma@pcb.com](mailto:rma@pcb.com)

For a complete list of distributors, global offices and sales representatives, visit our website, [www.pcb.com](http://www.pcb.com).

## Safety Considerations

This product is intended for use by qualified personnel who recognize shock hazards and are familiar with the precautions required to avoid injury. While our equipment is designed with user safety in mind, the protection provided by the equipment may be impaired if equipment is used in a manner not specified by this manual.

Discontinue use and contact our 24-Hour Sensorline if:

- Assistance is needed to safely operate equipment
- Damage is visible or suspected
- Equipment fails or malfunctions

For complete equipment ratings, refer to the enclosed specification sheet for your product.

## Definition of Terms and Symbols

The following symbols may be used in this manual:



### DANGER

Indicates an immediate hazardous situation, which, if not avoided, may result in death or serious injury.

**CAUTION**

Refers to hazards that could damage the instrument.

**NOTE**

Indicates tips, recommendations and important information. The notes simplify processes and contain additional information on particular operating steps.

**The following symbols may be found on the equipment described in this manual:**



This symbol on the unit indicates that high voltage may be present. Use standard safety precautions to avoid personal contact with this voltage.



This symbol on the unit indicates that the user should refer to the operating instructions located in the manual.



This symbol indicates safety, earth ground.



PCB工业监视和测量设备 - 中国RoHS2公布表

PCB Industrial Monitoring and Measuring Equipment - China RoHS 2 Disclosure Table

部件名称	有害物质					
	铅 (Pb)	汞 (Hg)	镉 (Cd)	六价铬 (Cr(VI))	多溴联苯 (PBB)	多溴二苯醚 (PBDE)
住房	0	0	0	0	0	0
PCB板	X	0	0	0	0	0
电气连接器	0	0	0	0	0	0
压电晶体	X	0	0	0	0	0
环氧	0	0	0	0	0	0
铁氟龙	0	0	0	0	0	0
电子	0	0	0	0	0	0
厚膜基板	0	0	X	0	0	0
电线	0	0	0	0	0	0
电缆	X	0	0	0	0	0
塑料	0	0	0	0	0	0
焊接	X	0	0	0	0	0
铜合金/黄铜	X	0	0	0	0	0
本表格依据 SJ/T 11364 的规定编制。						
0：表示该有害物质在该部件所有均质材料中的含量均在 GB/T 26572 规定的限量要求以下。						
X：表示该有害物质至少在该部件的某一均质材料中的含量超出 GB/T 26572 规定的限量要求。						
铅是欧洲RoHS指令2011/65/ EU附件三和附件四目前由于允许的豁免。						

CHINA RoHS COMPLIANCE

Component Name	Hazardous Substances					
	Lead (Pb)	Mercury (Hg)	Cadmium (Cd)	Chromium VI Compounds (Cr(VI))	Polybrominated Biphenyls (PBB)	Polybrominated Diphenyl Ethers (PBDE)
Housing	O	O	O	O	O	O
PCB Board	X	O	O	O	O	O
Electrical Connectors	O	O	O	O	O	O
Piezoelectric Crystals	X	O	O	O	O	O
Epoxy	O	O	O	O	O	O
Teflon	O	O	O	O	O	O
Electronics	O	O	O	O	O	O
Thick Film Substrate	O	O	X	O	O	O
Wires	O	O	O	O	O	O
Cables	X	O	O	O	O	O
Plastic	O	O	O	O	O	O
Solder	X	O	O	O	O	O
Copper Alloy/Brass	X	O	O	O	O	O

This table is prepared in accordance with the provisions of SJ/T 11364.

O: Indicates that said hazardous substance contained in all of the homogeneous materials for this part is below the limit requirement of GB/T 26572.

X: Indicates that said hazardous substance contained in at least one of the homogeneous materials for this part is above the limit requirement of GB/T 26572.

Lead is present due to allowed exemption in Annex III or Annex IV of the European RoHS Directive 2011/65/EU.

72787

PCB Piezotronics Inc. claims proprietary rights in the information disclosed hereon. Neither it nor any reproduction thereof will be disclosed to others without the written consent of PCB Piezotronics Inc.

REVISIONS		
REV	DESCRIPTION	DIN
NR	RELEASED TO DRAFTING	50245

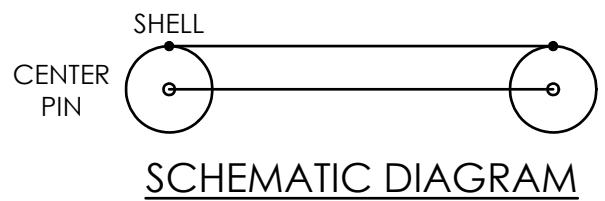
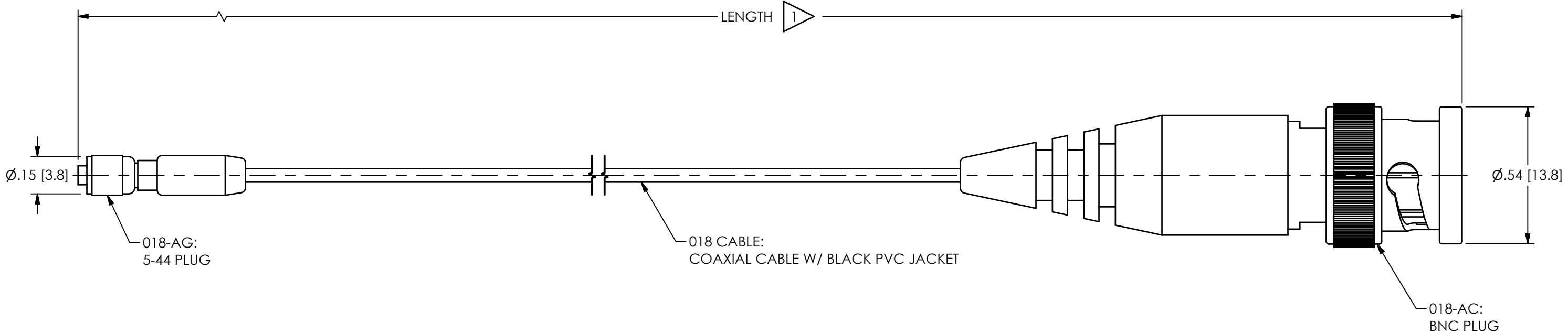

1 LENGTH WILL VARY IN FEET OR METERS DEPENDING ON THE MODEL

CABLE LENGTH TOLERANCE	
LENGTH	TOLERANCE
1"-11"	+1"/-0"
1'-4'	+4"/-0"
5'-99'	+6"/-0"
99'+	+1"/-0"

UNLESS OTHERWISE SPECIFIED TOLERANCES ARE:	
DIMENSIONS IN INCHES	DIMENSIONS IN MILLIMETERS [IN BRACKETS]
DECIMALS XX ±.03 XXX ±.010	DECIMALS X ± 0.8 XX ± 0.25
ANGLES ± 2 DEGREES	ANGLES ± 2 DEGREES
FILLETS AND RADII .003 - .005	FILLETS AND RADII 0.07 - 0.13

DRAWN	CHECKED		ENGINEER	
	JES	1/7/20	BAM	1/7/20
TITLE				
OUTLINE DRAWING 018CXX SERIES & 018AGXXXAC SERIES COAXIAL CABLE W/ 5-44 & BNC PLUGS				

**PCB PIEZOTRONICS™**  
 3425 WALDEN AVE. DEPEW, NY 14043  
 (716) 684-0001 E-MAIL: sales@pcb.com

CODE IDENT. NO. 52681	DWG. NO. <b>72787</b>
SCALE: 2.5X	SHEET 1 OF 1



**Model 105C22**

**Subminiature ICP® pressure sensor, 1 mV/psi, 0.099" dia. diaphragm, 10-32 mtg thd**

**Installation and Operating Manual**

**For assistance with the operation of this product,  
contact the PCB Piezotronics, Inc.**

**Toll-free: 716-684-0001  
24-hour SensorLine: 716-684-0001  
Fax: 716-684-0987  
E-mail: [info@pcb.com](mailto:info@pcb.com)  
Web: [www.pcb.com](http://www.pcb.com)**





## Repair and Maintenance

PCB guarantees Total Customer Satisfaction through its “Lifetime Warranty Plus” on all Platinum Stock Products sold by PCB and through its limited warranties on all other PCB Stock, Standard and Special products. Due to the sophisticated nature of our sensors and associated instrumentation, **field servicing and repair is not recommended and, if attempted, will void the factory warranty.**

Beyond routine calibration and battery replacements where applicable, our products require no user maintenance. Clean electrical connectors, housings, and mounting surfaces with solutions and techniques that will not harm the material of construction. Observe caution when using liquids near devices that are not hermetically sealed. Such devices should only be wiped with a dampened cloth—never saturated or submerged.

In the event that equipment becomes damaged or ceases to operate, our Application Engineers are here to support your troubleshooting efforts 24 hours a day, 7 days a week. Call or email with model and serial number as well as a brief description of the problem.

## Calibration

Routine calibration of sensors and associated instrumentation is necessary to maintain measurement accuracy. We recommend calibrating on an annual basis, after exposure to any extreme environmental influence, or prior to any critical test.

PCB Piezotronics is an ISO-9001 certified company whose calibration services are accredited by A2LA to ISO/IEC 17025, with full traceability to SI through N.I.S.T. In addition to our standard calibration services, we also offer specialized tests, including: sensitivity at elevated or cryogenic temperatures, phase response, extended high or low frequency response, extended range, leak testing, hydrostatic pressure testing, and others. For more information, contact your local PCB Piezotronics distributor, sales representative, or factory customer service representative.

## Returning Equipment

If factory repair is required, our representatives will provide you with a Return Material Authorization (RMA) number, which we use to reference any information you have already provided and expedite the repair process. This number should be clearly marked on the outside of all returned package(s) and on any packing list(s) accompanying the shipment.

## Contact Information

PCB Piezotronics, Inc.  
3425 Walden Ave.  
Depew, NY14043 USA  
Toll-free: (800) 828-8840  
24-hour SensorLine: (716) 684-0001  
General inquiries: [info@pcb.com](mailto:info@pcb.com)  
Repair inquiries: [rma@pcb.com](mailto:rma@pcb.com)

For a complete list of distributors, global offices and sales representatives, visit our website, [www.pcb.com](http://www.pcb.com).

## Safety Considerations

This product is intended for use by qualified personnel who recognize shock hazards and are familiar with the precautions required to avoid injury. While our equipment is designed with user safety in mind, the protection provided by the equipment may be impaired if equipment is used in a manner not specified by this manual.

Discontinue use and contact our 24-Hour Sensorline if:

- Assistance is needed to safely operate equipment
- Damage is visible or suspected
- Equipment fails or malfunctions

For complete equipment ratings, refer to the enclosed specification sheet for your product.

## Definition of Terms and Symbols

The following symbols may be used in this manual:



### **DANGER**

Indicates an immediate hazardous situation, which, if not avoided, may result in death or serious injury.

**CAUTION**

Refers to hazards that could damage the instrument.

**NOTE**

Indicates tips, recommendations and important information. The notes simplify processes and contain additional information on particular operating steps.

**The following symbols may be found on the equipment described in this manual:**



This symbol on the unit indicates that high voltage may be present. Use standard safety precautions to avoid personal contact with this voltage.



This symbol on the unit indicates that the user should refer to the operating instructions located in the manual.



This symbol indicates safety, earth ground.



PCB工业监视和测量设备 - 中国RoHS2公布表

PCB Industrial Monitoring and Measuring Equipment - China RoHS 2 Disclosure Table

部件名称	有害物质					
	铅 (Pb)	汞 (Hg)	镉 (Cd)	六价铬 (Cr(VI))	多溴联苯 (PBB)	多溴二苯醚 (PBDE)
住房	0	0	0	0	0	0
PCB板	X	0	0	0	0	0
电气连接器	0	0	0	0	0	0
压电晶体	X	0	0	0	0	0
环氧	0	0	0	0	0	0
铁氟龙	0	0	0	0	0	0
电子	0	0	0	0	0	0
厚膜基板	0	0	X	0	0	0
电线	0	0	0	0	0	0
电缆	X	0	0	0	0	0
塑料	0	0	0	0	0	0
焊接	X	0	0	0	0	0
铜合金/黄铜	X	0	0	0	0	0
本表格依据 SJ/T 11364 的规定编制。						
0：表示该有害物质在该部件所有均质材料中的含量均在 GB/T 26572 规定的限量要求以下。						
X：表示该有害物质至少在该部件的某一均质材料中的含量超出 GB/T 26572 规定的限量要求。						
铅是欧洲RoHS指令2011/65/ EU附件三和附件四目前由于允许的豁免。						

CHINA RoHS COMPLIANCE

Component Name	Hazardous Substances					
	Lead (Pb)	Mercury (Hg)	Cadmium (Cd)	Chromium VI Compounds (Cr(VI))	Polybrominated Biphenyls (PBB)	Polybrominated Diphenyl Ethers (PBDE)
Housing	O	O	O	O	O	O
PCB Board	X	O	O	O	O	O
Electrical Connectors	O	O	O	O	O	O
Piezoelectric Crystals	X	O	O	O	O	O
Epoxy	O	O	O	O	O	O
Teflon	O	O	O	O	O	O
Electronics	O	O	O	O	O	O
Thick Film Substrate	O	O	X	O	O	O
Wires	O	O	O	O	O	O
Cables	X	O	O	O	O	O
Plastic	O	O	O	O	O	O
Solder	X	O	O	O	O	O
Copper Alloy/Brass	X	O	O	O	O	O

This table is prepared in accordance with the provisions of SJ/T 11364.

O: Indicates that said hazardous substance contained in all of the homogeneous materials for this part is below the limit requirement of GB/T 26572.

X: Indicates that said hazardous substance contained in at least one of the homogeneous materials for this part is above the limit requirement of GB/T 26572.

Lead is present due to allowed exemption in Annex III or Annex IV of the European RoHS Directive 2011/65/EU.

PCB Piezotronics Inc. claims proprietary rights in the information disclosed hereon. Neither it nor any reproduction thereof will be disclosed to others without the written consent of PCB Piezotronics Inc.

11205

REVISIONS		
REV	DESCRIPTION	DIN
A	UPDATED MOUNTING HOLE INFORMATION	52565

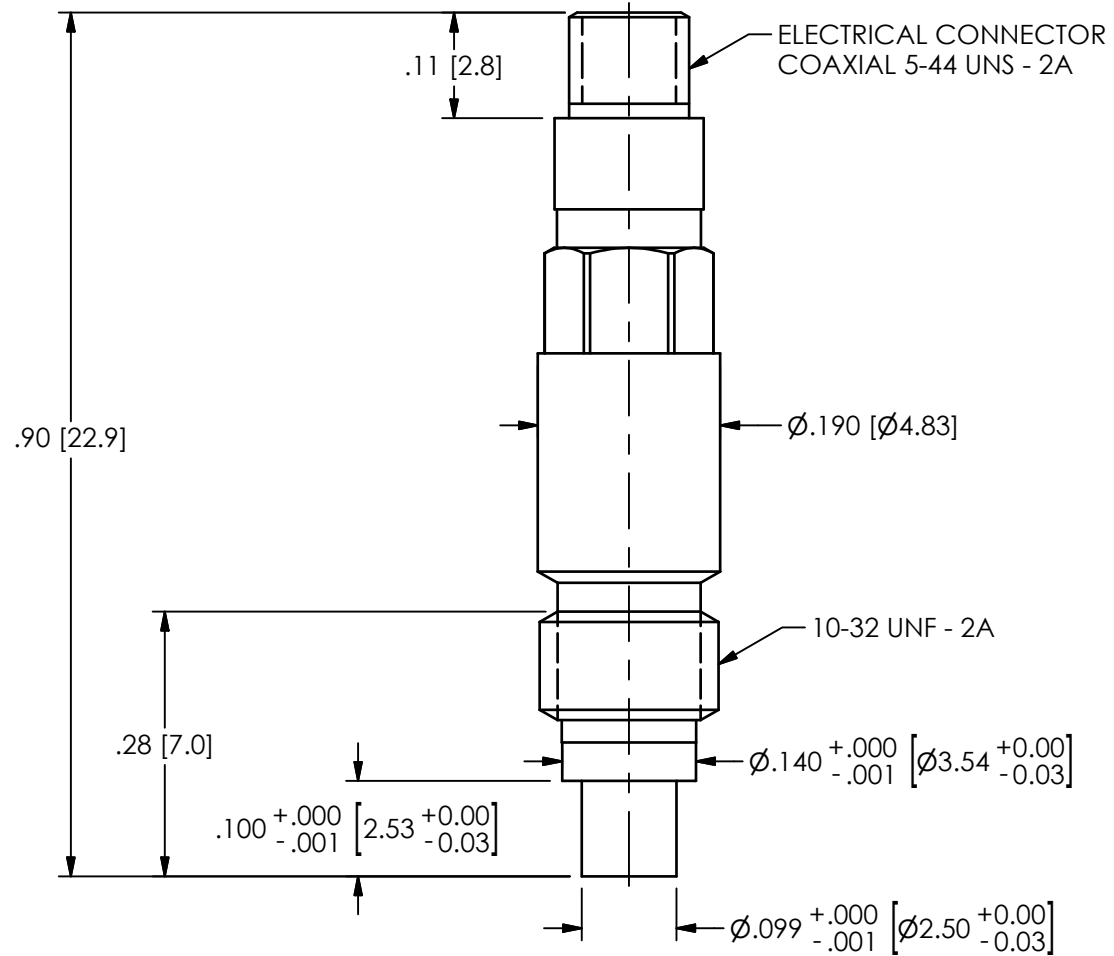
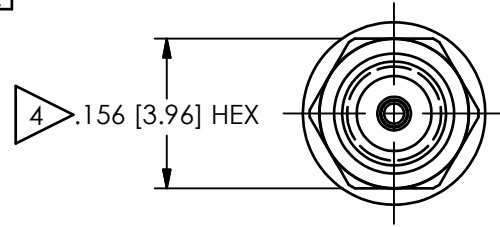

**FLUSH MOUNT**

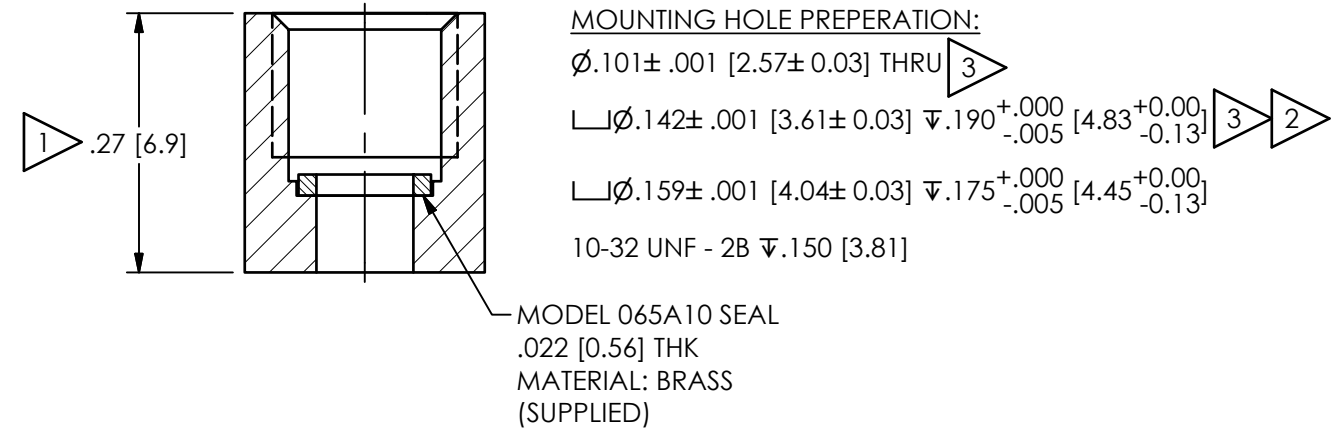

**RECESSED MOUNT**

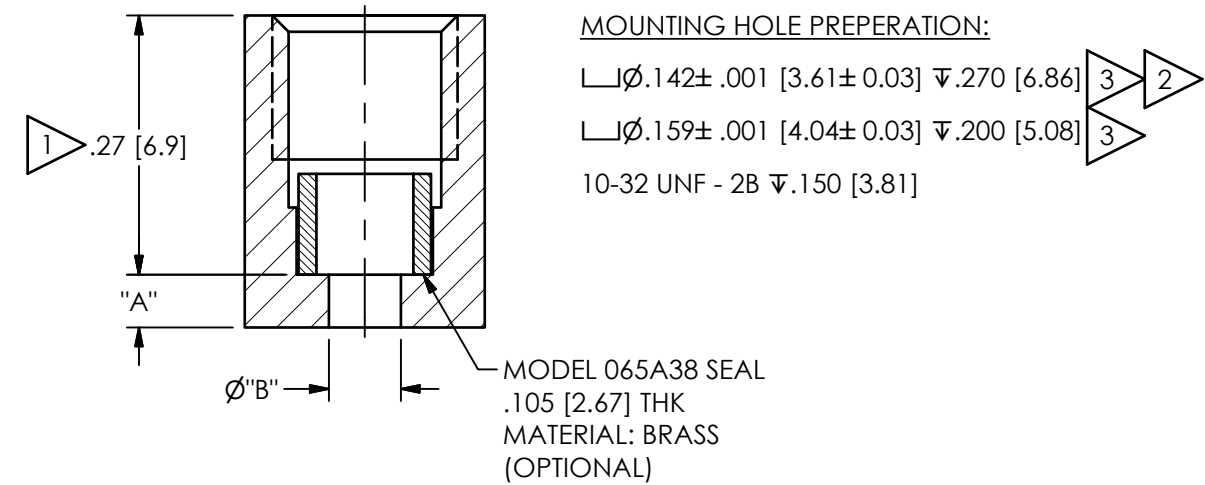

5.) DIMENSIONS "A" & "B" TO SUIT USERS REQUIREMENTS

- 4 RECOMMENDED MOUNTING TORQUE ON .156 [4.00] HEX TO BE 15 IN-LBS [169 Ncm]
- 3 THESE DIAMETERS MUST BE CONCENTRIC TO WITHIN .001 [0.03] TIR
- 2 SEAL SURFACES MUST BE FLAT AND FREE OF TOOL MARKS WITH A MIN SURFACE FINISH OF 63 [1.6]
- 1 FOR INSTALLATIONS DEEPER THAN .27 [6.9] └─∅.250 [6.35] TO CLEAR BODY

UNLESS OTHERWISE SPECIFIED TOLERANCES ARE:		DRAWN		CHECKED		ENGINEER		PCB PIEZOTRONICS AN AMPHENOL COMPANY	
DIMENSIONS IN INCHES DECIMALS XX ±.01 XXX ±.005 ANGLES ± 2 DEGREES	DIMENSIONS IN MILLIMETERS [ IN BRACKETS ] DECIMALS X ± 0.3 XX ± 0.13 ANGLES ± 2 DEGREES	JJF	2/17/22	JJF	2/17/22	NJL	2/17/22	3425 WALDEN AVE. DEPEW, NY 14043 (716) 684-0001 E-MAIL: sales@pcb.com	
CABLE TOLERANCES IN ENGLISH 1" ≤ LENGTH < 1' = +1' / - 0 1' ≤ LENGTH < 5' = +2' / - 0 5' ≤ LENGTH < 100' = +6' / - 0 100' ≤ LENGTH = +1' / - 0	CABLE TOLERANCES IN METRIC 2.54cm ≤ LENGTH < 30.5cm = +2.54cm / - 0 30.5cm ≤ LENGTH < 1.5m = +5.1cm / - 0 1.5m ≤ LENGTH < 30.5m = +15.2cm / - 0 30.5m ≤ LENGTH = +30.5cm / - 0	TITLE						CODE IDENT. NO. 52681	DWG. NO. 11205
FILLETS AND RADII .003 - .005	FILLETS AND RADII 0.07 - 0.13	INSTALLATION DRAWING MODEL 105CX2 SERIES PRESSURE SENSOR						SCALE: 5X	SHEET 1 OF 1