

49985

PCB Piezotronics Inc. claims proprietary rights in the information disclosed hereon. Neither it nor any reproduction thereof will be disclosed to others without the written consent of PCB Piezotronics Inc.

REVISIONS		
REV	DESCRIPTION	DIN
A	ADDED MOUNTING HOLE PREP INFO	44844

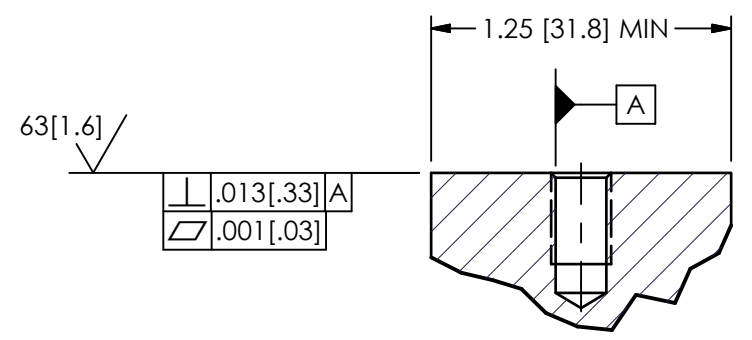
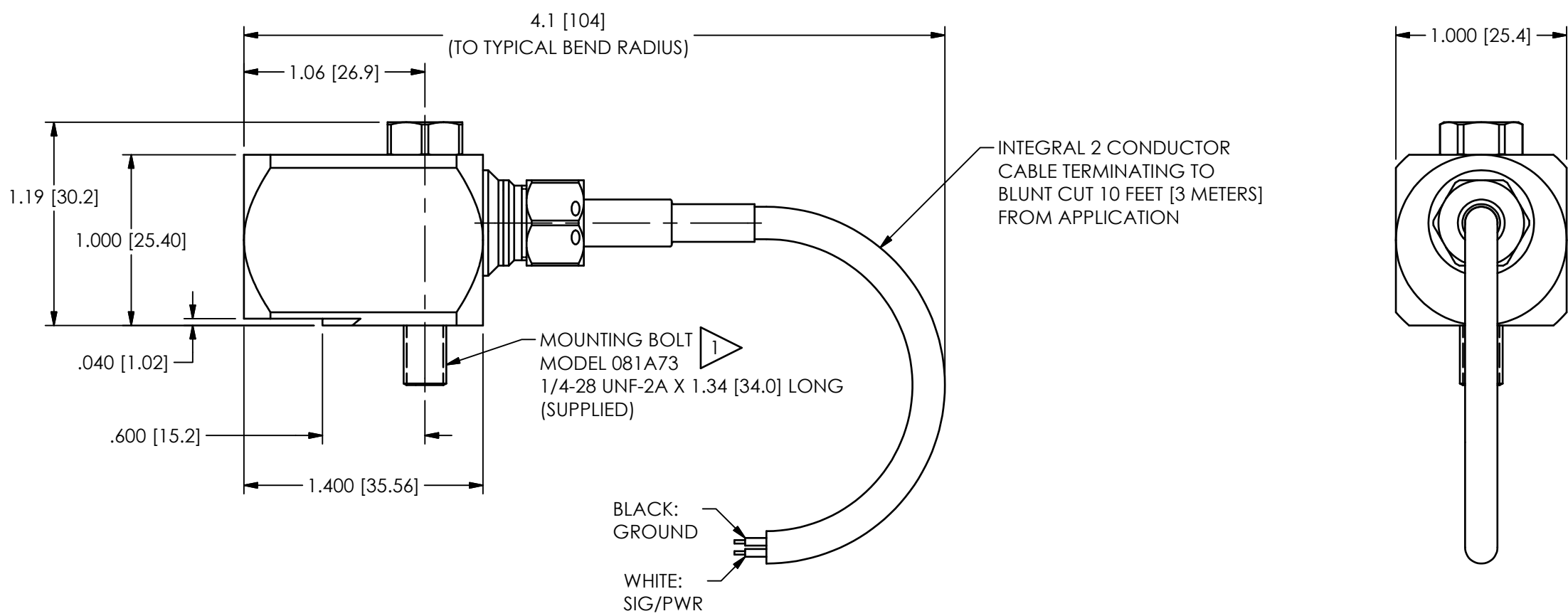

MOUNTING HOLE PREPARATION  
 $\varnothing.218[5.54] \nabla .50[12.7] \text{ MIN}$   
 $1/4\text{-}28 \text{ UNF-}2\text{B} \nabla .38[9.7] \text{ MIN}$

(M) OPTION  
 $\varnothing.199[5.05] \nabla .50[12.7] \text{ MIN}$   
 $M6 \times 1.0\text{-}6\text{H} \nabla .38[9.7] \text{ MIN}$

1 FOR METRIC ACCELEROMETER USE METRIC MOUNTING BOLT MODEL M081A73, M6x1.0-6g X 1.34[34.0] LONG.

UNLESS OTHERWISE SPECIFIED TOLERANCES ARE:		DRAWN		CHECKED		ENGINEER	
DIMENSIONS IN INCHES	DIMENSIONS IN MILLIMETERS [IN BRACKETS]	BB	11/30/15	ECB	11/30/15	BAM	11/30/15
DECIMALS XX ±.03 XXX ±.010	DECIMALS X ±0.8 XX ±0.25	TITLE INSTALLATION DRAWING ACCELEROMETER					
ANGLES ± 2 DEGREES	ANGLES ± 2 DEGREES						
FILLETS AND RADII .003 - .005	FILLETS AND RADII 0.07 - 0.13	CODE IDENT. NO. 52681		DWG. NO. 49985		SCALE: 1.25X SHEET 1 OF 1	

**PCB PIEZOTRONICS**  
 3425 WALDEN AVE. DEPEW, NY 14043  
 (716) 684-0001 E-MAIL: sales@pcb.com