

MEMS DC Response Accelerometers

with Internal Amplifier and Differential Output Signal

- Constant and Low Frequency Acceleration Measurements
- Aerospace Vibration Testing – Flutter, GVT, etc.
- Simulated Environmental Testing with Shakers & Centrifuges
- Servohydraulic Vehicular Ride Simulation & Comfort Studies
- Suspension, Shock Absorption, and Damping Studies



Series 3741
MEMS DC Response
Accelerometer

Series 3741 MEMS DC response accelerometers are offered in a variety of full-scale ranges, from ± 2 to ± 200 g, to accommodate many aerospace and automotive testing requirements. The units feature silicon MEMS sensing elements for uniform, repeatable performance. Gas damping, mechanical over-range stops, and a low-profile, hard-anodized, aluminum housing are utilized for added durability.

Electrically, the units offer a differential output signal for common-mode noise rejection and incorporate many advanced features, including supply voltage regulation, ability to operate from +6 to +30 VDC excitation, and a proprietary temperature compensation circuit for stable performance over the entire operating temperature range. Each unit is provided with an integral, 4-conductor, 10 ft. (3 m) shielded cable. An optional mounting adaptor facilitates triaxial measurement configurations.

As with all PCB® instrumentation, these sensors are complemented with toll-free applications assistance, 24-hour customer service, and are backed by a no-risk policy that guarantees satisfaction or your money refunded.



Specifications

Visit www.pcb.com for detailed specifications and drawings for specific models

Series 3741 MEMS DC Response Accelerometers - Performance Specifications

Voltage Sensitivity ($\pm 5\%$)		Measurement Range		Frequency Range		Typical Resonant Frequency	Broadband Resolution	
English	SI	English	SI	($\pm 5\%$)	($\pm 10\%$)		English	SI
10 mV/g	1.02 mV/m/s ²	± 200 g pk	± 1960 m/s ² pk	0 to 1500 Hz	0 to 2000 Hz	>6000 Hz	5.1 mg rms	0.050 m/s ² rms
20 mV/g	2.04 mV/m/s ²	± 100 g pk	± 980 m/s ² pk	0 to 1500 Hz	0 to 2000 Hz	>6000 Hz	4.5 mg rms	0.044 m/s ² rms
40 mV/g	4.1 mV/m/s ²	± 50 g pk	± 490 m/s ² pk	0 to 1000 Hz	0 to 2000 Hz	>3000 Hz	2.5 mg rms	0.0245 m/s ² rms
66.7 mV/g	6.80 mV/m/s ²	± 30 g pk	± 294.2 m/s ² pk	0 to 1000 Hz	0 to 2000 Hz	>3000 Hz	2.5 mg rms	0.0245 m/s ² rms
200 mV/g	20.4 mV/m/s ²	± 10 g pk	± 98 m/s ² pk	0 to 100 Hz	0 to 200 Hz	>900 Hz	1.1 mg rms	0.0108 m/s ² rms
1000 mV/g	102 mV/m/s ²	± 2 g pk	± 19.6 m/s ² pk	0 to 70 Hz	0 to 150 Hz	>600 Hz	0.27 mg rms	0.00268 m/s ² rms

Performance	English	SI
Non Linearity	$\leq 1\%$ FS	$\leq 1\%$ FS
Transverse Sensitivity	$\leq 3\%$	$\leq 3\%$

Environmental	English	SI
Overload Limit (shock)	$\pm 10,000$ g pk	$\pm 98,100$ m/s ² pk
Temperature Range (operating) [1]	-65 to +250 °F	-54 to +121 °C
Temperature Range (storage)	-65 to +250 °F	-54 to +121 °C
Temperature Coefficient of Sensitivity	$\pm 3\%$	$\pm 3\%$
Zero g Offset Temperature Coefficient [2]	$\pm 2\%$ FSO	$\pm 2\%$ FSO
Base Strain Sensitivity (at 250 $\mu\epsilon$)	0.01 g	0.10 m/s ²

Electrical	English	SI
Excitation Voltage	6 to 30 VDC	6 to 30 VDC
Current Consumption	< 7.5 mA	< 7.5 mA
Output Impedance	≤ 100 ohm	≤ 100 ohm
Offset Voltage (0 g)	± 50 mVDC	± 50 mVDC
Common Mode Voltage (± 0.1 VDC)	+2.5 VDC	+2.5 VDC
Electrical Isolation (Base)	>30M ohm	>30M ohm

Physical	English	SI
Housing Material	Anodized Aluminum	Anodized Aluminum
Sealing	Epoxy	Epoxy
Size (h x l x w)	0.30 x 1.0 x 0.85 in	7.62 x 25.4 x 21.6 mm
Weight (without cable)	0.35 oz	9.92 gm
Electrical Connector	Integral Cable	Integral Cable
Cable Termination	Pigtail Ends	Pigtail Ends
Cable Type	4-cond. Teflon jacket	4-cond. Teflon jacket
Cable Length	10 ft	3 m
Mounting	Through Holes (2)	Through Holes (2)

Supplied Accessories
Model 081A103 Mounting Screw (2 pcs)
Model M081A103 Metric Mounting Screw (2 pcs)
Model ACS-11 or ACS-56 NIST traceable calibration

Optional Accessories
Model 080A208 Triaxial Mounting Block

Notes
[1] Compensated over entire operating range.
[2] FSO = Full Scale Output over the Measurement Range (4 VDC).



Actual Size

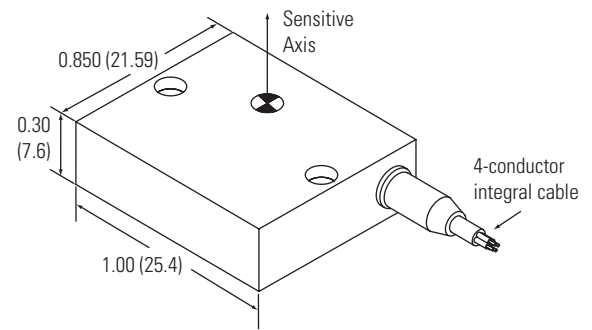

Series 3741
MEMS DC Response Accelerometer

Dimensions shown are in inches (millimeters)

CE These products conform to applicable European Directives for CE marking.



Model Numbering System for Series 3741 MEMS DC Response Accelerometers							
1.) Series							
3741	Single axis, MEMS DC response accelerometer with standard, 10 ft. (3.0 m) integral cable and pigtail termination						
2.) Full scale output							
D	± 2 VDC						
3.) Excitation voltage							
4	+6 to +30 VDC						
4.) Electrical connection							
HB	Shielded, 4-conductor, Teflon jacket, integral cable (Series 010)						
5.) Measurement Range							
2G	± 2 g						
10G	± 10 g						
30G	± 30 g						
50G	± 50 g						
100G	± 100 g						
200G	± 200 g						
6.) Integral cable length (add only if selecting integral cable other than standard 10 ft. (3.0 m) length)							
/XXX	Specify XXX as desired cable length in feet (specify MXXX for desired cable lengths in meters)						
7.) Cable termination (add only if selecting integral cable with other than standard pigtail termination)							
HW	9-pin D-sub plug for mating to Model 478A30 signal conditioner						
Examples:							
3741	D	4	HB	2G	/005	HW	Single axis MEMS DC response accelerometer with ± 2 g measurement range, ± 2 VDC full-scale output, integral 5 ft. cable with 9-pin D-sub plug termination.

Optional Accessories

Model 036A10

Cable Assembly

- Pigtails to 9-pin D-sub connector
- 10 ft (3 m) length
- Other lengths available
- Mates directly with Model 478A30 DC sensor signal conditioner



Model 036A10
Cable Assembly

Model 080A208

Triaxial Mounting Block

- Adapts three sensors for triaxial measurements

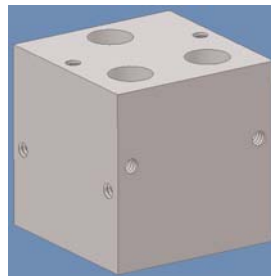

Model 080A208
Triaxial Mounting Block

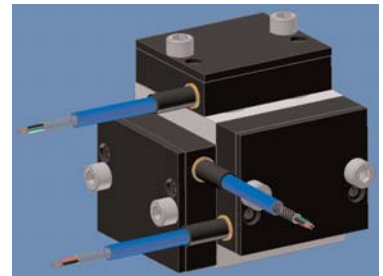

Mounting Block with Installed Sensors



Signal Conditioning

Visit www.pcb.com for detailed specifications and drawings for specific models

Series 3741 MEMS DC response accelerometers contain a built-in voltage regulator which permits them to be operated from any unregulated power supply with an excitation voltage of +6 to +30 VDC. This excitation voltage is delivered to the sensor across the power and ground leads. Separate positive and negative signal leads transmit the resulting differential measurement signal to readout or recording instruments. Many data acquisition systems will offer excitation for direct connection to a variety of sensor types. Check the features of your instrument to determine compatibility, and whether a separate excitation power source will be required.

Each Series 3741 accelerometer possesses an inherent DC offset voltage of up to ± 50 mV at 0 g. To ensure accurate measurements, this offset should be zeroed out, or "nulled". Many readout devices, such as oscilloscopes, offer a zero adjustment for such purposes; however, in the event that the readout device does not offer such capability, an alternate method should be considered. If DC response is not necessary, the signal path may be AC coupled into the readout device, to eliminate the DC offset. If there is no method for nulling the offset voltage, then the offset should be measured, recorded, and taken into account when analyzing the measurement result.

PCB offers the Model 478A30 3-channel DC sensor signal conditioner, specifically for use with Series 3741 accelerometers. The significant feature of this device is the automatic zero adjustment capability for elimination of the sensor's inherent DC offset voltage. To eliminate data acquisition compatibility issues and confusion, use of Model 478A30 signal conditioner for Series 3741 accelerometers is highly recommended. The unit powers up to three measurement channels of accelerometers, and offers BNC output connectors for easy hookup to readout and recording instruments. Additional features include gain adjustment and variable excitation.

Model 478A30

3-channel DC Sensor Signal Conditioner

- Differential input
- Three independent channels
- 100/115/230 VAC powered
- 0 to 14 VDC sensor excitation
- Frequency range from 0 to 150 kHz (optional filter modules)
- Gain adjustment from 0 to 999.9
- Automatic zero
- 10 V pk output
- 9-pin D-sub input connector
- BNC output connectors



Model 478A30
3-channel, DC Sensor Signal Conditioner



3425 Walden Avenue, Depew, NY 14043-2495 USA

Vibration Division toll free 888-684-0013

24-hour SensorLineSM 716-684-0001

Fax 716-685-3886 E-mail vibration@pcb.com

Web site www.pcb.com

ISO 9001:2000 CERTIFIED

AS9100:2004 CERTIFIED

A2LA ACCREDITED to ISO 17025

© 2006 PCB Group, Inc. In the interest of constant product improvement, specifications are subject to change without notice.
PCB, ICP, and Modally Tuned are registered trademarks of PCB Group, Inc.
SensorLine is a service mark of PCB Group, Inc. All other trademarks are properties of their respective owners.

VIB-3741-1006

Printed in U.S.A.

The Vibration Division of PCB® Piezotronics, Inc. specializes in the development, application, and support of shock and vibration sensors, microphones, impact hammers, piezoelectric actuators, and dynamic strain sensors for acceleration measurements, acoustic testing, and structural testing requirements. This product focus, coupled with the strengths and resources of PCB, permits the Vibration Division to offer exceptional customer service, 24-hour technical assistance, and a **Total Customer Satisfaction** guarantee.

Visit www.pcb.com to locate
your nearest sales office