

MODEL 421A25

# Industrial Charge Amplifier

Facilitates Product Quality Monitoring & Automated Machinery Control

- 13 remote selectable input ranges
- 3 additional ranges with continuous gain adjustment
- Long discharge time constant
- Peak hold and analog outputs
- Two adjustable alarm outputs
- Integral test function

The Model 421A25 industrial charge amplifier is designed for piezoelectric charge output force or strain sensors and is ideally suited for monitoring manufacturing forces experienced during assembly, crimping, stamping or product testing. With its long discharge time constant and high frequency response, both quasi-static and dynamic measurements up to 20 kHz are possible.



Series 421A25  
Industrial Charge Amplifier

The unit synchronizes with machine cycles through a reset feature while analog and peak hold outputs allow for real-time monitoring. Two adjustable set points trigger digital alarm outputs when levels are exceeded. An integral test function enables a check of the measuring chain without a sensor being connected. All adjustments are set by either remote control or RS-232 interface — and the settings are maintained when the power is disconnected. The RS-232 may also be used to transfer measurement data. The unit is packaged in a rugged, CE marked aluminum enclosure, well suited for harsh industrial environments.

As with all PCB® instrumentation, this product is complemented with toll-free applications assistance, 24-hour customer service, and is backed by a no-risk policy that guarantees satisfaction or your money refunded.

 **PCB PIEZOTRONICS**<sup>INC.</sup>  
FORCE / TORQUE DIVISION

*Total Customer Satisfaction Guaranteed*



## Specifications

Model	421A25
Performance	English
Channels	1
Input Range (adjustable)	$\pm 100$ to $\pm 1,000,000$ pC
Output Voltage (Instantaneous)	$\pm 10$ V
Output Voltage (Peak)	0 to 10 V
Frequency Response (-3 dB) ( $\leq 100k$ pC)	$\sim 0$ to 20 kHz
Frequency Response (-3 dB) ( $>100k$ pC)	$\sim 0$ to $>2$ kHz
Accuracy	$\pm 1\%$ FS
Non-Linearity	$<0.02\%$ FS
Control Input	$\pm 5$ to 45 V
Alarm Output (Dual)	45 V, 100 mA
Environmental	
Temperature Range (Operating)	+23 to +140 °F (-5 to +60 °C)
Temperature Range (Storage)	-4 to +176 °F (-20 to +80 °C)
Electrical	
Power Required	15 to 35 VDC
Current Draw	$<70$ mA
Broadband Electrical Noise	$<20$ mV pp
Output Resistance	10 ohm
Drift	$<0.03$ pC/s
DC Offset (max)	$\pm 10$ mV
Physical	
Size (l x w x h) — Overall	3.9 x 3.1 x 1.3 in (98 x 79 x 34 mm)
Enclosure Material	Aluminum
Electrical Connector (input)	BNC Jack
Electrical Connector (output, setup, control, power)	25-Pin D-Sub

**Notes:**

This product conforms to applicable European Directives for CE marking.

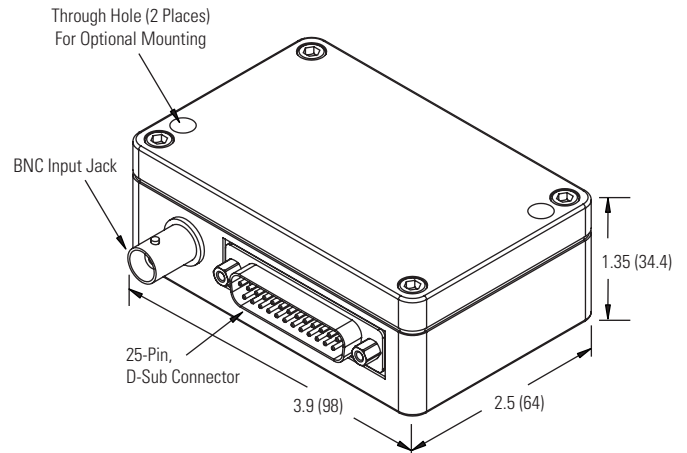

**Model 421A25**  
Industrial Charge Amplifier  
*measurements in inches (millimeters)*



3425 Walden Avenue, Depew, NY 14043-2495 USA  
**Force / Torque Division toll free 888-684-0004**  
**24-hour SensorLine<sup>SM</sup> 716-684-0001**  
**Fax 716-684-8877 E-mail force@pcb.com**  
**Web site www.pcb.com**

ISO 9001:2000 CERTIFIED

A2LA ACCREDITED to ISO 17025

© 2006 PCB Group, Inc. In the interest of constant product improvement, specifications are subject to change without notice.  
 PCB, ICP, and Torkdisc are registered trademarks of PCB Group, Inc.  
 SensorLine is a service mark of PCB Group, Inc. All other trademarks are properties of their respective owners.

FTQ-421A25-0506

Printed in U.S.A.

The Force/Torque Division of PCB® Piezotronics, Inc. specializes in the development, application, and support of piezoelectric and strain gage force sensors, load cells, and torque sensors for a wide range of research, test, measurement, monitoring, and control requirements. This product focus, coupled with the strengths and resources of PCB, permits the Force/Torque Division to offer exceptional customer service, 24-hour technical assistance, and a **Total Customer Satisfaction** guarantee.

Visit [www.pcb.com](http://www.pcb.com) to locate your nearest sales office